

CATALOG | OCTOBER 2025

Low voltage

Process performance cast iron motors

400 V 50 Hz, 460V 60 Hz

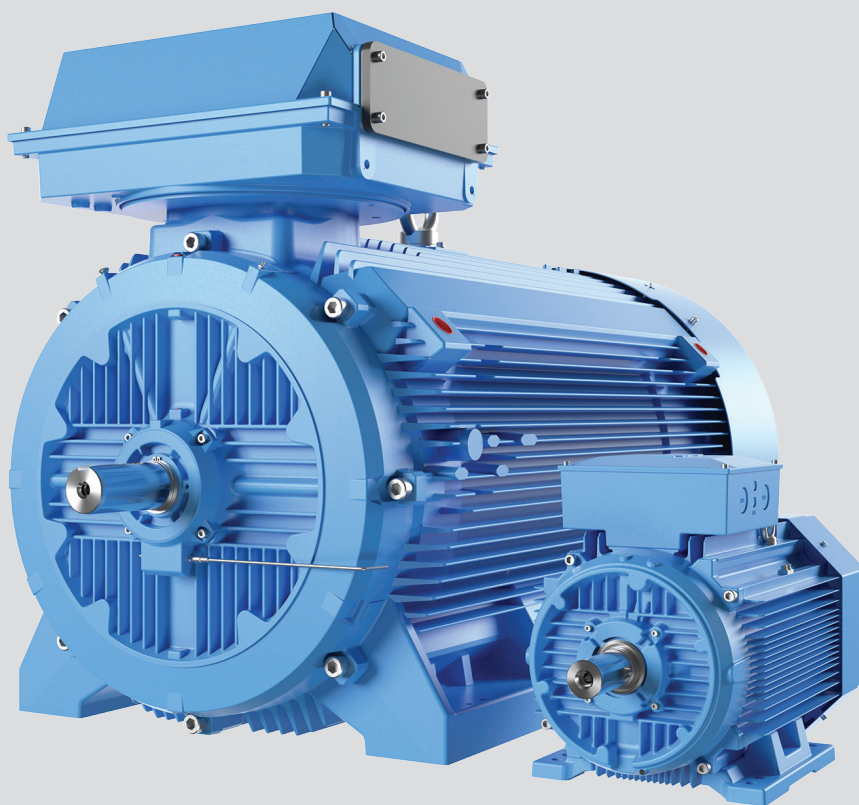

With expertise, and a comprehensive portfolio of products and life-cycle services, we help value-minded industrial customers improve their energy efficiency and productivity.

Low voltage Process performance motors

Sizes 71 to 500, 0.09 to 1300 kW

4	International motor efficiency standards and regulations
7	Mounting arrangements
8	Cooling
9	Degrees of protection: IP code/IK code
10	Insulation
11	Voltage and frequency
12	Surface treatment
13	Variable speed drives/ variable frequency drives with Process performance motors
16	Ordering information
17	Rating plates
18	Technical data
50	Variant codes
76	Mechanical design
89	Terminal box
101	Dimension drawings
105	Accessories
112	Motors in brief
115	Motor construction
116	ABB Access
117	Total product offering
118	ABB's portfolio of drives

International motor efficiency standards and regulations

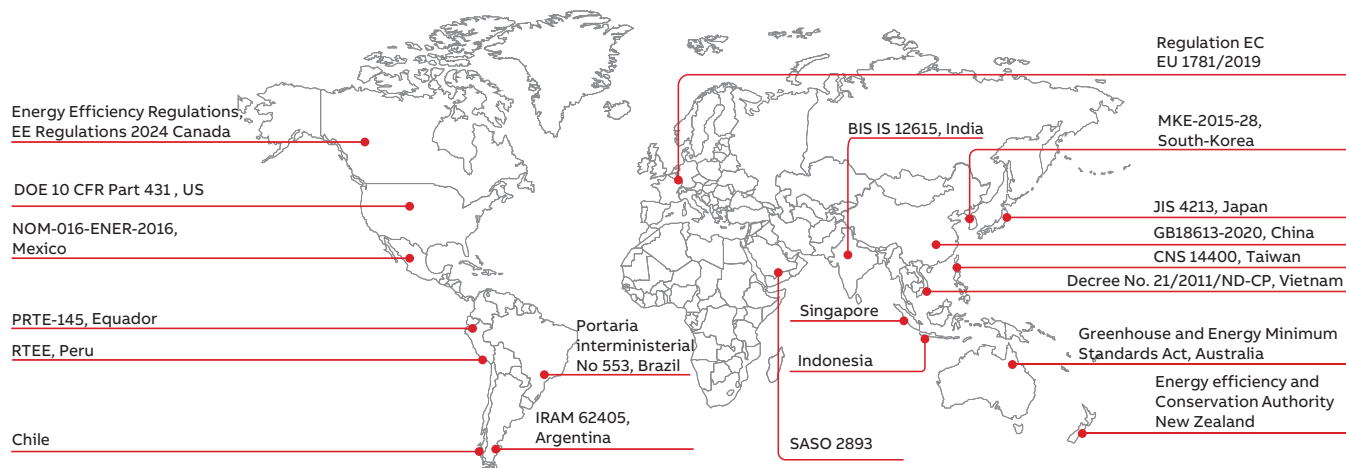

IEC 60034-30-1 is the worldwide energy efficiency classification standard for low voltage three-phase asynchronous motors. International IEC standards are created to enable and increase the level of harmonization in efficiency regulations, safety and many other areas around the world, and to also cover motors and other equipment for explosive atmospheres.

IEC 60034-30-1 with all past and future editions defines International Efficiency (IE) classes for single speed, three-phase, 50 Hz and 60 Hz induction motors. The efficiency levels defined therein are based on the test method specified in IEC 60034-2-1. Both standards are part of an effort to unify motor testing procedures with CSA390-10 and IEEE 112 standards as well as efficiency and product labeling (IE) requirements to enable motor purchasers worldwide to easily recognize premium efficiency products.

To promote transparency in the market, IEC 60034-30-1 states that both the efficiency class and efficiency value must be shown on the motor rating plate and in product documentation.

Minimum energy performance standards

While the IEC as an international standardization organization sets guidelines for motor testing and efficiency classes, IEC does not regulate efficiency levels in countries. The biggest drivers for mandatory Minimum Energy Performance Standard (MEPS) levels for electric motors are global climate change, government targets to curb CO₂ emissions and globally rising electricity demand. The whole value chain, from manufacturer up to end user, must be aware of the legislation in order to meet local requirements, to save energy and reduce the carbon footprint.

Harmonized global standards and the increasing adoption of MEPS around the world are good news for all. However, it is important to remember that harmonization is an ongoing process. Even though MEPS are already in effect in several regions and countries, they are evolving and differ in terms of scope and requirements. At the same time, more countries are planning to adopt their own MEPS regulations. A view of existing and coming global MEPS regulations can be seen on the World map above.

To get the latest information please visit www.abb.com/motors&generators/energyefficiency.

IEC 60034-30-1 ED2

This standard defines four International Efficiency (IE) classes for single speed electric motors that are rated according to IEC 60034-1 or IEC 60079-0 (explosive atmospheres) and designed for operation on sinusoidal voltage.

- IE5 = Ultra premium efficiency
- IE4 = Super premium efficiency
- IE3 = Premium efficiency, identical to the table in 10CFR431 ('NEMA Premium') in the USA and CSA C390-10:2015 for 60 Hz
- IE2 = High efficiency
- IE1 = Standard efficiency

Most of the different technical constructions of electric motors are covered as long as they are rated for direct on-line operation. The coverage of the IEC 60034-30-1 includes:

- single speed electric motors (single and three-phase), 50 and 60 Hz
- 2, 4, 6 and 8 poles
- Rated output P_N from 0.12 kW to 1000 kW
- Rated voltage U_N above 50 V up to 1 kV
- Motors capable of continuous operation at their rated power with a temperature rise within the specified insulation temperature class
- Motors, marked with any ambient temperature within the range of $-20\text{ }^{\circ}\text{C}$ to $+60\text{ }^{\circ}\text{C}$
- Motors, marked with an altitude up to 4000 m above sea level

By comparing IEC 60034-30-1 to CSA C390-10:2015 and "10CFR431 Subpart B – Electric motors", it can be seen that the efficiency limits and tables are well aligned and their major difference is in the scope of the output power where CSA and 10CFR431 have a maximum power of 500 hp. There are also some minor differences in the scope of excluded motors.

Note: CFR is Code of Federal Regulations.

The following motors are excluded from IEC 60034-30-1:

- Single-speed motors with 10 or more poles or multi-speed motors
- Motors completely integrated into a machine (for example pump, fan or compressor) that cannot be tested separately from the machine
- Brake motors, when the brake cannot be dismantled or separately fed

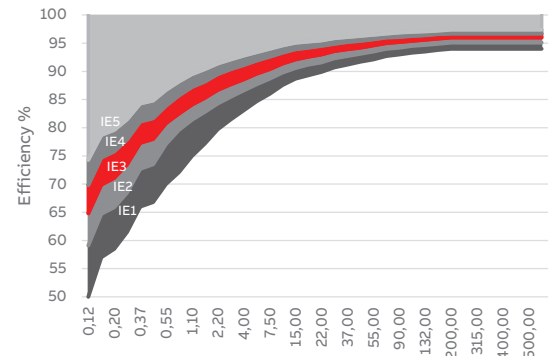

—
01

ABB and efficiency standards

ABB determines efficiency values according to IEC 60034-2-1 using the low uncertainty method (i.e. summation of losses), with additional load losses determined by the method of residual loss.

It is good to mention and emphasize that the IEC 60034-2-1 test method, which is known as an indirect method, is technically equivalent to the test methods in the standards CSA 390-10 and IEEE 112 Method B leading to the equivalent losses and thus efficiency values. All three test methods are recognized and accepted today in US and Canada and any of the three methods may be used for compliance purposes to both countries.

As the world market leader, ABB offers the largest range of LV motors available. It has long advocated the need for efficiency in motors, and high efficiency products have formed the core of its portfolio for many years. The core of ABB's product portfolio is based on a full range of IE3 and IE4 motors – with many available from stock. ABB is the originator of the Energy Efficiency Movement empowering at scale adoption of energy efficiency within industry, to accelerate the world towards net-zero.

Nominal efficiency limits defined in IEC 60034-30-1 ED2 (reference values at 50 Hz, based on test methods specified in IEC 60034-2-1)

Output kW	IE1 Standard efficiency				IE2 High efficiency				IE3 Premium efficiency				IE4 Super Premium efficiency				IE5 Ultra premium efficiency			
	2 pole	4 pole	6 pole	8 pole	2 pole	4 pole	6 pole	8 pole	2 pole	4 pole	6 pole	8 pole	2 pole	4 pole	6 pole	8 pole	2 pole	4 pole	6 pole	8 pole
0.12	45.0	50.0	38.3	31.0	53.6	59.1	50.6	39.8	60.8	64.8	57.7	50.7	66.5	69.8	64.9	62.3	71.4	74.3	69.8	67.4
0.18	52.8	57.0	45.5	38.0	60.4	64.7	56.6	45.9	65.9	69.9	63.9	58.7	70.8	74.7	70.1	67.2	75.2	78.7	74.6	71.9
0.20	54.6	58.5	47.6	39.7	61.9	65.9	58.2	47.4	67.2	71.1	65.4	60.6	71.9	75.8	71.4	68.4	76.2	79.6	75.7	73
0.25	58.2	61.5	52.1	43.4	64.8	68.5	61.6	50.6	69.7	73.5	68.6	64.1	74.3	77.9	74.1	70.8	78.3	81.5	78.1	75.2
0.37	63.9	66.0	59.7	49.7	69.5	72.7	67.6	56.1	73.8	77.3	73.5	69.3	78.1	81.1	78	74.3	81.7	84.3	81.6	78.4
0.40	64.9	66.8	61.1	50.9	70.4	73.5	68.8	57.2	74.6	78	74.4	70.1	78.9	81.7	78.7	74.9	82.3	84.8	82.2	78.9
0.55	69.0	70.0	65.8	56.1	74.1	77.1	73.1	61.7	77.8	80.8	77.2	73	81.5	83.9	80.9	77	84.6	86.7	84.2	80.6
0.75	72.1	72.1	70.0	61.2	77.4	79.6	75.9	66.2	80.7	82.5	78.9	75	83.5	85.7	82.7	78.4	86.3	88.2	85.7	82
1.1	75.0	75.0	72.9	66.5	79.6	81.4	78.1	70.8	82.7	84.1	81	77.7	85.2	87.2	84.5	80.8	87.8	89.5	87.2	84
1.5	77.2	77.2	75.2	70.2	81.3	82.8	79.8	74.1	84.2	85.3	82.5	79.7	86.5	88.2	85.9	82.6	88.9	90.4	88.4	85.5
2.2	79.7	79.7	77.7	74.2	83.2	84.3	81.8	77.6	85.9	86.7	84.3	81.9	88	89.5	87.4	84.5	90.2	91.4	89.7	87.2
3	81.5	81.5	79.7	77.0	84.6	85.5	83.3	80	87.1	87.7	85.6	83.5	89.1	90.4	88.6	85.9	91.1	92.1	90.6	88.4
4	83.1	83.1	81.4	79.2	85.8	86.6	84.6	81.9	88.1	88.6	86.8	84.8	90	91.1	89.5	87.1	91.8	92.8	91.4	89.4
5.5	84.7	84.7	83.1	81.4	87	87.7	86	83.8	89.2	89.6	88	86.2	90.9	91.9	90.5	88.3	92.6	93.4	92.2	90.4
7.5	86.0	86.0	84.7	83.1	88.1	88.7	87.2	85.3	90.1	90.4	89.1	87.3	91.7	92.6	91.3	89.3	93.3	94	92.9	91.3
11	87.6	87.6	86.4	85.0	89.4	89.8	88.7	86.9	91.2	91.4	90.3	88.6	92.6	93.3	92.3	90.4	94	94.6	93.7	92.2
15	88.7	88.7	87.7	86.2	90.3	90.6	89.7	88	91.9	92.1	91.2	89.6	93.3	93.9	92.9	91.2	94.5	95.1	94.3	92.9
18.5	89.3	89.3	88.6	86.9	90.9	91.2	90.4	88.6	92.4	92.6	91.7	90.1	93.7	94.2	93.4	91.7	94.9	95.3	94.6	93.3
22	89.9	89.9	89.2	87.4	91.3	91.6	90.9	89.1	92.7	93	92.2	90.6	94	94.5	93.7	92.1	95.1	95.5	94.9	93.6
30	90.7	90.7	90.2	88.3	92	92.3	91.7	89.8	93.3	93.6	92.9	91.3	94.5	94.9	94.2	92.7	95.5	95.9	95.3	94.1
37	91.2	91.2	90.8	88.8	92.5	92.7	92.2	90.3	93.7	93.9	93.3	91.8	94.8	95.2	94.5	93.1	95.8	96.1	95.6	94.4
45	91.7	91.7	91.4	89.2	92.9	93.1	92.7	90.7	94	94.2	93.7	92.2	95	95.4	94.8	93.4	96	96.3	95.8	94.7
55	92.1	92.1	91.9	89.7	93.2	93.5	93.1	91	94.3	94.6	94.1	92.5	95.3	95.7	95.1	93.7	96.2	96.5	96	94.9
75	92.7	92.7	92.6	90.3	93.8	94	93.7	91.6	94.7	95	94.6	93.1	95.6	96	95.4	94.2	96.5	96.7	96.3	95.3
90	93.0	93.0	92.9	90.7	94.1	94.2	94	91.9	95	95.2	94.9	93.4	95.8	96.1	95.6	94.4	96.6	96.9	96.5	95.5
110	93.3	93.3	93.3	91.1	94.3	94.5	94.3	92.3	95.2	95.4	95.1	93.7	96	96.3	95.8	94.7	96.8	97	96.6	95.7
132	93.5	93.5	93.5	91.5	94.6	94.7	94.6	92.6	95.4	95.6	95.4	94	96.2	96.4	96	94.9	96.9	97.1	96.8	95.9
160	93.8	93.8	93.8	91.9	94.8	94.9	94.8	93	95.6	95.8	95.6	94.3	96.3	96.6	96.2	95.1	97	97.2	96.9	96.1
200	94.0	94.0	94.0	92.5	95	95.1	95	93.5	95.8	96	95.8	94.6	96.5	96.7	96.3	95.4	97.2	97.4	97	96.3
250	94.0	94.0	94.0	92.5	95	95.1	95	93.5	95.8	96	95.8	94.6	96.5	96.7	96.5	95.4	97.2	97.4	97	96.3
315	94.0	94.0	94.0	92.5	95	95.1	95	93.5	95.8	96	95.8	94.6	96.5	96.7	96.6	95.4	97.2	97.4	97	96.3
355	94.0	94.0	94.0	92.5	95	95.1	95	93.5	95.8	96	95.8	94.6	96.5	96.7	96.6	95.4	97.2	97.4	97	96.3
400	94.0	94.0	94.0	92.5	95	95.1	95	93.5	95.8	96	95.8	94.6	96.5	96.7	96.6	95.4	97.2	97.4	97	96.3
450	94.0	94.0	94.0	92.5	95	95.1	95	93.5	95.8	96	95.8	94.6	96.5	96.7	96.6	95.4	97.2	97.4	97	96.3
500-1000	94.0	94.0	94.0	92.5	95	95.1	95	93.5	95.8	96	95.8	94.6	96.5	96.7	96.6	95.4	97.2	97.4	97	96.3

Mounting arrangements

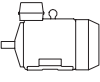
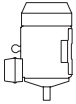
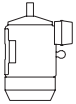
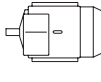
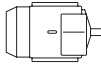
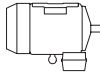
Foot-mounted motor						Product code pos. 12
Code I / code II						A: foot-mounted, term. box top
						
IM B3	IM V5	IM V6	IM B6	IM B7	IM B8	
IM 1001	IM 1011	IM 1031	IM 1051	IM 1061	IM 1071	

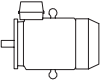
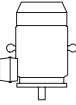
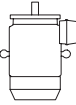
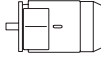
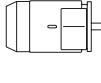
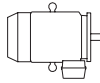
Flange-mounted motor, large flange						Product code pos. 12
Code I / code II						B: flange mounted, large flange
						
IM B5	IM V1	IM V3	*)	*)	*)	
IM 3001	IM 3011	IM 3031	IM 3051	IM 3061	IM 3071	

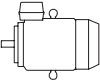
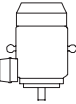
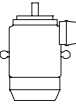
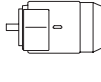
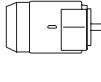
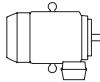
Flange-mounted motor, small flange						Product code pos. 12
Code I / code II						C: flange mounted, small flange
						
IM B14	IM V18	IM V19	*)	*)	*)	
IM 3601	IM 3611	IM 3631	IM 3651	IM 3661	IM 3671	

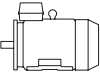
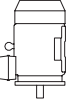
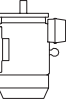
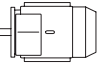
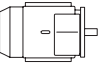
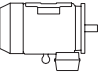
Foot- and flange-mounted motor with feet, large flange						Product code pos. 12
Code I / code II						H: foot/flange-mounted, term. box top
						
IM B35	IM V15	IM V35	*)	*)	*)	
IM 2001	IM 2011	IM 2031	IM 2051	IM 2061	IM 2071	

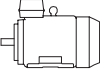
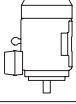
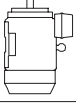
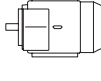
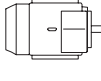
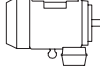
Foot- and flange-mounted motor with feet, small flange						Product code pos. 12
Code I / code II						J: foot/flange-mounted, small flange
						
IM B34	IM V17					
IM 2101	IM 2111	IM 2131	IM 2151	IM 2161	IM 2171	

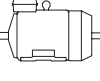
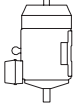
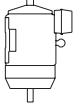
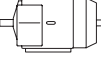
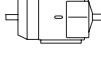
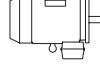
Foot-mounted motor, shaft with free extensions						Product code pos. 12
Code I / code II						
						
IM 1002	IM 1012	IM 1032	IM 1052	IM 1062	IM 1072	

*) Not stated in IEC 60034-7.

Note: If the motor is mounted shaft upwards, take measures to prevent water or any other liquid from running down the shaft into the motor.

Cooling

Designation system concerning methods of cooling refers to standard IEC 60034-6.

Explanation of the product code

International Cooling	Circuit arrangement	Primary coolant	Method of movement of primary coolant	Secondary coolant	Method of movement of secondary coolant
IC	4	(A)	1	(A)	6
	1	2	3	4	5

Position 1

0:	Free circulation (open circuit)
4:	Free circulation (open circuit)

Position 2

A:	For air (omitted for simplified designation)
----	--

Position 3

0:	Free convection
1:	Self-circulation
6:	Machine-mounted independent component

Position 4

A:	For air (omitted for simplified designation)
W:	For water

Position 5

0:	Free convection
1:	Self-circulation
6:	Machine-mounted independent component
8:	Relative displacement

Degrees of protection: IP code/IK code

Classification of degrees of protection provided by enclosures of rotating machines are refers to:

- Standard IEC 60034-5 or EN 60529 for IP code
- Standard EN 50102 for IK code

IP protection

Protection of persons against getting in contact with (or approaching) live parts and against contact with moving parts inside the enclosure. Also protection of the machine against ingress of solid foreign objects. Protection of machines against the harmful effects due to the ingress of water.

Explanation of the IP code

Ingress protection	Degree of protection to persons and to parts of the motors inside the enclosure	Degree of protection provided by the enclosure with respect to harmful effects due to ingress of water
IP	5	5
	1	2

Position 1

2:	Motors protected against solid objects greater than 12 mm
4:	Motors protected against solid objects greater than 1 mm
5:	Dust-protected motors
6:	Dust-tight motors

Position 2

3:	Motors protected against spraying water
4:	Motors protected against splashing water
5:	Motors protected against water jets
6:	Motors protected against heavy seas

IK code

Classification of degrees of protection provided by enclosure for motors against external mechanical impacts.

Explanation of the IK code

International mechanical protection	Characteristic group
IK	08
	1

Position 1

Relation between IK code and impact energy:

IK code	Impact energy/Joule
0:	Not protected according to EN 50102
01:	0.15
02:	0.2
03:	0.35
04:	0.5
05:	0.7
06:	1
07:	2
08:	5 (ABB Standard)
09:	10
10:	20

Insulation

01 Safety margins per thermal class

ABB uses class F insulation, which, with temperature rise B, is the most common requirement among industry today.

The use of class F insulation with class B temperature rise gives ABB products a 25 °C safety margin. This can be used to increase the loading for limited periods, to operate at higher ambient temperatures or altitudes, or with greater voltage and frequency tolerances. It can also be used to extend insulation. For instance, a 10 K temperature reduction will extend the insulation life.

Thermal class 130 (B)

- Nominal ambient temperature 40 °C
- Max permissible temperature rise 80 K
- Hot spot temperature margin 10 K

Thermal class 155 (F)

- Nominal ambient temperature 40 °C
- Max permissible temperature rise 105 K
- Hot spot temperature margin 10 K

Thermal class 180 (H)

- Nominal ambient temperature 40 °C
- Max permissible temperature rise 125 K
- Hot spot temperature margin 15 K

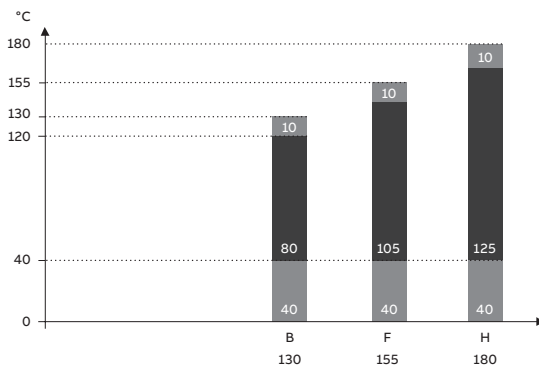

01

Voltage and frequency

01 Voltage and frequency deviation in zones A and B

The impact on temperature rise caused by voltage and frequency fluctuation is defined in IEC 60034-1. The standard divides the combinations into two zones, A and B. Zone A is the combination of voltage deviation of $\pm 5\%$ and frequency deviation of $\pm 2\%$. Zone B is the combination of voltage deviation of $\pm 10\%$ and frequency deviation of $\pm 4\%$. This is illustrated in figure below.

Motors are capable of supplying the rated torque in both zones A and B, but the temperature rise will be higher than at rated voltage and frequency. Motors can be run in zone B only for a short period of time.

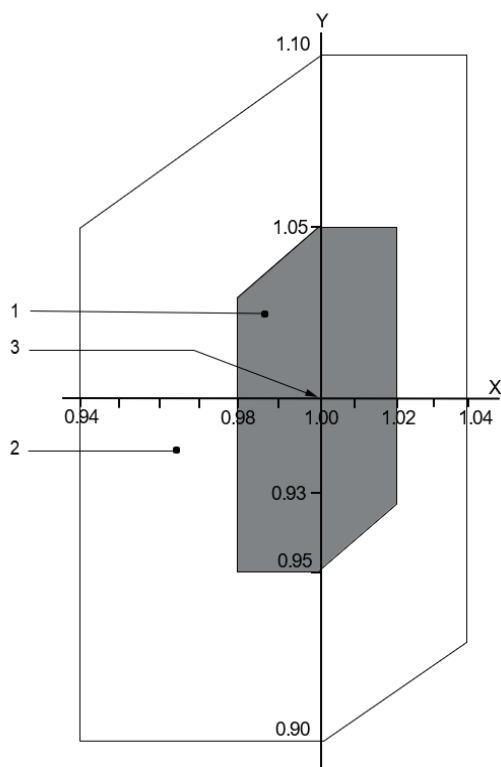

01

Key

X axis	frequency p.u.
Y axis	voltage p.u.
1	zone A
2	zone B (outside zone A)
3	rating point

Surface treatment

The standard surface treatment of the Process performance motors is designed to meet corrosivity category C3, both outdoors and indoors. This also meets the requirements in C1 and C2.

The corrosivity categories are defined in standard ISO12944-2.

Special surface treatments for other corrosivity categories as well as offshore environments are available as options.

The standard ABB paint color for motors is Munsell blue 8B 4.5/3.25, except for special systems such as NORSOK where a specific color is requested.

Atmospheric-corrosivity categories and examples of typical environments

Corrosivity category	Examples of typical environments (informative only)	
	Exterior	Interior
C1	-	Heated buildings with clean atmospheres, e.g., offices, shops, schools, hotels
C2	Atmospheres with low levels of pollution: mostly rural areas	Unheated buildings where condensation can occur, e.g., depots, sports halls
C3	Urban and industrial atmospheres, moderate sulfur dioxide pollution; coastal areas with low salinity	Production rooms with high humidity and some air pollution, e.g., food-processing plants, laundries, breweries, dairies
C4	Industrial areas and coastal areas with moderate salinity	Chemical plants, swimming pools, coastal ship- and boatyards
C5	Industrial areas with high humidity and an aggressive atmosphere, and coastal areas with high salinity	Buildings or areas with almost permanent condensation and with high pollution
CX	Offshore areas with high salinity, and industrial areas with extreme humidity and an aggressive atmosphere, and sub-tropical and tropical atmospheres	Industrial areas with extreme humidity and an aggressive atmosphere

Variable speed drives/ variable frequency drives with Process performance motors

—
01 Isotherm loadability curves for motors with 50 Hz nominal frequency

Variable speed drives (VSD) provide significant benefits when used together with ABB Process performance motors. The advantages include better process control and energy savings through a regulation of motor speed, and smooth starting with a reduced inrush current, reducing the stress on the equipment and supply network.

By choosing an ABB motor–drive package, users can be confident that the motor and drive combination is optimized for their application; it is a working package with a proven performance.

Process performance motors are designed for both direct on line (DOL) and variable speed operation, and will, either as standard or by adding a few extras, be suitable for variable speed operations.

When selecting process performance motors for VSDs, the following points must be taken into consideration. The DriveSize selection tool helps in selecting the optimal combination of motor, drive and supply transformer.

1. Motor loadability with variable speed drives

The difference in the temperature rise of a motor run direct on line compared to the same motor run with a drive is influenced by factors such as the cooling effect of a shaft-mounted fan, depending on the speed of the motor, increased losses due to harmonics generated by the drive and reduced flux above the field weakening point. The effects of all these factors are combined in the loadability table.

The motor's maximum continuous loadability depends on the motor's actual temperature rise and the desired or allowed maximum temperature rise, typically class B or class F. Use the DriveSize dimensioning tool to choose the right motor and drive for your application. In DriveSize, you can specify the desired temperature rise and the tool scales the loadability curve according to the actual motor temperature rise.

Many applications also demand short time overloadability. In the DriveSize tool, you can also specify short time overload needs and the tool will choose the right products for your task.

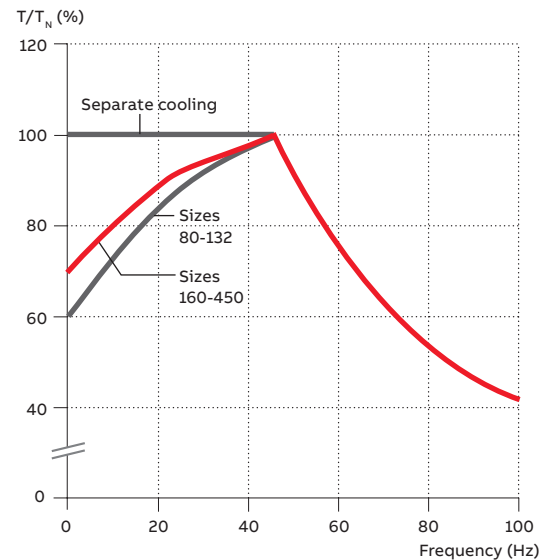

—
01

2. Operating speed

Process performance motors are designed to work over a wide speed range and also at speeds significantly higher than nominal. The maximum speeds can be found on motor rating plates or in DriveSize. In addition to the motor speed, make sure that the maximum or critical speed of the entire application is not exceeded.

3. Ventilation

When the motor is operating at low speeds, the cooling capacity of the fan decreases, which again reduces the motor's load capacity. A separate, constant-speed fan (variant codes 183, 422, 514) can be used to increase the cooling capacity at low speed, if required for loads with constant torque characteristics.

4. Lubrication

The lubrication interval of regreasable bearings depends on the running speed of the motor and the bearing temperature. Motors are delivered as standard with a lubrication plate in tabular format that states the relubrication intervals at different speeds and temperatures. Please refer to the installation, operation and safety manual for further information on lubrication.

5. Winding insulation

The output voltage of voltage source frequency converters consists of steep voltage pulses. These pulses can be even higher and steeper when arriving at the motor terminals due to reflecting pulses in the cables. The motor's insulation must therefore be selected according to the actual pulses at the motor terminals.

5.1 Maximum voltage peaks

Two different insulation systems are available for ABB motors covered in this catalogue. The Special insulation can be ordered by using variant code +405. Otherwise motors are delivered with Standard insulation. Limit values for insulation systems are listed in Table 1. These values apply at motor terminals. The pk/pk values define motor insulation capacity regardless of the origin of the voltage stress. The pk values are given as reference. Typically highest stress occurs in pk/pk situation where pk/pk can be up to 2 x pk.

Table 1. Limit values for ABB motor insulation systems.

		Standard insulation	+ 405 Special insulation
U _{phase-ground}	V _{pk/pk}	2500	3300
	V _{pk}	1250	1650
U _{phase-phase}	V _{pk/pk}	3400	4800
	V _{pk}	1700	2400
Rise time Tr > acc. to IEC 60034-18-41		0,24 μs	0,24 μs
Rise time Tr > acc. To NEMA MG 1-2021		0,1 μs	0,1 μs
Voltage rise, max.		5,7 kV/μs	7,8 kV/μs
Time between pulses		> 6 μs	> 6 μs

5.2 IVIC classes

IEC 60034-18-41 specifies limit values for different IVIC classes. The most typical classes specified for variable speed duty are IVIC B and C. Limit values are depending on network voltage. Table 2 includes limit values for IVIC B and C for the most typical network voltages. Limit values increase linearly according to network voltage.

Table 2. Limit values for different IVIC classes and network voltages

Network voltage		400 V		480 V		500 V		575 V		690 V	
		IVIC B	IVIC C	IVIC B	IVIC C	IVIC B	IVIC C	IVIC B	IVIC C	IVIC B	IVIC C
U _{phase-ground}	V _{pk/pk}	1248	1664	1497	1997	1560	2080	1794	2392	2153	2870
U _{phase-phase}	V _{pk/pk}	1783	2377	2139	2852	2228	2971	2563	3417	3075	4100

5.3 Guidance for ABB motor insulation system selection for use with ABB frequency converters

Choose ABB motor insulation system so that given requirements are reached. IVIC C/C is also reached with this selection

Table 3. Requirements for ABB motor insulation system when used with ABB frequency converters.

Nominal AC line voltage	Requirements for motor insulation system ¹⁾
Un ≤ 420 V	U _{phase-phase, pk} ≥ 1250 V Rise time minimum 0,25 μs , IEC
420 V < Un ≤ 500 V	U _{phase-phase, pk} ≥ 1486 V Rise time minimum 0,25 μs , IEC
500 V < Un ≤ 600 V	U _{phase-phase, pk} ≥ 1783 V Rise time minimum 0,25 μs , IEC
600 V < Un ≤ 690 V	U _{phase-phase, pk} ≥ 2050 V Rise time minimum 0,25 μs , IEC

¹⁾ Consult ABB Drives publications for more details if needed

5.4 ABB motor insulation system selection with other frequency converters

Select ABB motor insulation system so that it meets or exceeds frequency converter manufacturers requirements for motor insulation system and that IVIC C/C limit values are met. The shortest allowed voltage rise time at motor terminals is listed in Table 1. Voltage rise time is typically depending on frequency converter type, cable length and whether the frequency converter has dU/dt filter. The dU/dt filter is the most typical way to slow down voltage rise time to acceptable level if rise time is otherwise too short.

6. Bearing currents

Bearing voltages and currents must be avoided in all motors to ensure reliable operation of the entire application. Table below gives the selection rules, depending on motor output power and frame size, when used together with ABB drive products; the same rules can also be applied as guidance when using ABB Process performance motors with other manufacturers' drives.

Precautionary measures to avoid bearing currents in variable speed drives.

Nominal power (P_N and / or Frame size (IEC)	Precautionary measures
$P_N < 100$ kW	No action needed
$P_N \geq 100$ kW OR IEC 315 \leq Frame size \leq IEC 355	Insulated non-drive end bearing
$P_N \geq 350$ kW OR IEC 400 \leq Frame size \leq IEC 500	Insulated non-drive end bearing AND Common mode filter at the converter

Common mode filters

Common mode filters are installed at the output of the drive. These filters reduce common mode currents and, thus, decrease the risk of bearing currents. Common mode filters do not significantly affect the phase of main voltages on motor terminals. For more information, see the ABB drives documents.

Insulated bearings

ABB uses bearings with an insulated outer race or hybrid bearings with ceramic rolling elements.

Solutions for persistent bearing currents

In exceedingly rare cases, bearing currents might still exist even if the measures specified above have been taken. For such installations, there is an advanced method that would provide a remedy: insulated bearings at both ends.

Mount insulated bearings at both ends can either be bearings with an insulated outer cage, or hybrid bearings with ceramic rolling elements. Insulated bearings at both ends can be ordered by using variant code 702. Note that this variant cannot be combined with special drive-end bearing solutions, such as roller bearings or angular contact ball bearings.

7. Earthing and cabling

Cables with a symmetrical concentric protective earth should be used across the system.

Electromagnetic compatibility (EMC)

The high-frequency components in a variable frequency drive might cause electromagnetic interference with other equipment in the installation. To avoid this, certain measures should be taken. To meet EMC requirements, special EMC cables glands with a 360° connection to the concentric protective earth conductor should be used. Such cable glands can be used with variant code 704.

Ordering information

Explanation of the product code

Motor type	Motor size	Product code	Mounting arrangement code, Voltage and frequency code, Generation code	Variant codes
M3BP	160MLA	3GBP 161 410	- ADG	003, etc.
		1 2 3 4 5 6 7 8 9 10 11 12 13 14		

Positions 1 to 4

3GBP	Totally enclosed fan cooled squirrel cage motor with cast iron frame
------	--

Positions 5 and 6

IEC size	IEC size
07: 71	22: 225
08: 80	25: 250
09: 90	28: 280
10: 100	31: 315
12: 112	35: 355
13: 132	40: 400
16: 160	45: 450
18: 180	50: 500
20: 200	

Position 7

Speed (Pole pairs)
1: 2 poles
2: 4 poles
3: 6 poles
4: 8 poles
5: 10 poles
6: 12 poles
7: > 12 poles
8: Two-speed motors for fan drive motors for constant torque
9: Multi-speed motors, two-speed

Positions 8 to 10

8: Frame length
9: Stator package length
10: Speed for two-speed induction, Permanent Magnet, SynRM and High Speed motors

Position 11

-(dash)

Position 12 (marked with black dot in data tables)

Mounting arrangement
A: Foot-mounted, top-mounted terminal box
R: Foot-mounted, terminal box RHS seen from D-end
L: Foot-mounted, terminal box LHS seen from D-end
B: Flange-mounted, large flange
C: Flange-mounted, small flange (sizes 71 to 112)
H: Foot- and flange-mounted, terminal box top-mounted
J: Foot- and flange-mounted, small flange with tapped holes
S: Foot- and flange-mounted, terminal box RHS seen from D-end
T: Foot- and flange-mounted, terminal box LHS seen from D-end
V: Flange-mounted, special flange
F: Foot- and flange-mounted. Special flange

Position 13 (marked with black dot in data tables)

Voltage and frequency
Single-speed motors
B: 380 VΔ 50 Hz
D: 400 VΔ, 415 VΔ, 690 VY 50 Hz
E: 500 VΔ 50 Hz
F: 500 VY 50 Hz
S: 230 VΔ, 400 VY, 415 VY 50 Hz
T: 660 VΔ 50 Hz
U: 690 VΔ 50 Hz
X: Other rated voltage, connection or frequency, 690 V maximum

Position 14

Generation code
A, B, C...G...K: The product code must be, if needed, followed by variant codes.

Efficiency values are given according to IEC 60034-2-1; 2014.

For detailed dimension drawings please see our web-pages www.abb.com/motors&generators or contact ABB.

Rating plates

01 Rating plate example, motor size 100, IE2.

02 Rating plate example, motor size 160, K generation, IE3.

03 Rating plate example, motor size 315, IE4.

The motor's main rating plate shows the motor's performance values with various connections at nominal speed. The rating plate also shows the efficiency level (IE2, IE3, or IE4), year of manufacture, and the lowest nominal efficiency at 100, 75, and 50 % nominal load.

The plate samples shown on this page present typical data rows. The actual content of the plate may vary according to your order and according to the motor's IE class.

 ABB Oy, IEC LV Motors Strömbergin puistoie 5 A 65320 Vaasa, Finland							
IEC60034-1							
3- Motor		M3BP 280SMA 4 IMB3/IM1001				2023	
2300034-2							
No. 3G1F2309911730							
Ins. cl. F IP 55							
V	Hz	kW	r/min	A	cos φ	Duty	
690 Y	50	75	1484	78	0.85	S1	
400 D	50	75	1484	134	0.85	S1	
415 D	50	75	1485	131	0.84	S1	
IE2-94.5%(100%)-94.6%(75%)-93.9%(50%)							
Product code 3GBP282210-ADG +VC							
Nmax 2600 r/min							
6316/C3				6316/C3			
				635 kg			

01

 ABB Oy, IEC LV Motors Strömbergin puistoie 5 A 65320 Vaasa, Finland							
IEC60034-1							
3- Motor		M3BP 160MLA 4 IMB3/IM1001				2023	
2296173-10							
No. 3G1F2310910029							
Ins. cl. F IP 55							
V	Hz	kW	r/min	A	cos φ	Duty	
690 Y	50	11	1477	12.2	0.82	S1	
400 D	50	11	1477	21.1	0.82	S1	
660 Y	50	11	1474	12.7	0.83	S1	
380 D	50	11	1474	21.9	0.83	S1	
415 D	50	11	1479	20.5	0.81	S1	
460 D	60	11	1780	18.9	0.80	S1	
IE3-50Hz-91.4%(100%)-91.6%(75%)-90.6%(50%) / IE3-60Hz-92.4%(100%)							
Product code 3GBP162410-ADK +VC							
6309/C3							
				6209/C3			
				188 kg			

02

 ABB Oy, IEC LV Motors Strömbergin puistoie 5 A 65320 Vaasa, Finland							
IEC60034-1							
3- Motor		M3BP 250SMA 4 IMB3/IM1001				2023	
2280689-1							
No. 3G1F2303902994							
Ins. cl. F IP 55							
V	Hz	kW	r/min	A	cos φ	Duty	
690 Y	50	55	1483	57.9	0.83	S1	
400 D	50	55	1483	100	0.83	S1	
415 D	50	55	1485	98.7	0.81	S1	
460 D	60	55	1785	88.3	0.81	S1	
IE4-50Hz-95.7%(100%)-95.7%(75%)-95.3%(50%) / IE4-60Hz-95.8%(100%)							
Product code 3GBP252210-ADM							
6315/C3							
				6213/C3			
				482 kg			

04

Technical data

IE5 cast iron motors 400 V 50 Hz

IP 55 - IC 411 - Insulation class F, temperature rise class B

IE5 efficiency class according to IEC 60034-30-1; 2014

Output kW	Motor type	Product code	Efficiency IEC 60034-30-1: 2014					Current			Torque			Moment of inertia J = 1/4 GD ₂ kgm ₂	Weight kg	Sound pressure Level L _{PA} dB
			Speed r/min	Full load 100%	>3/4 load 75%	1/2 load 50%	Power factor Cos	I _n A	I _s /I _N	T _N Nm	T _i /T _N	T _b /T _N				
3000 r/min = 2 poles			400 V 50Hz					BASIC-design								
75	M3BP 280SMB 2	3GBP281220---R	2985	96,5	96,2	95,4	0,9	128	9,1	240	2,9	3,9	0,82	725	73	
75	M3BP 280SMB 2	3GBP281220---R	2983	96,5	96,3	95,5	0,9	127	9,1	240	2,6	3,5	0,82	725	73	
90	M3BP 280SMC 2	3GBP281230---R	2978	96,6	96,7	96,4	0,9	153	7,4	289	2,2	2,9	0,816	725	73	
90	M3BP 280SMC 2	3GBP281230---R	2980	96,6	96,7	96,3	0,9	154	7,9	288	2,4	3,2	0,816	725	73	
110	M3BP 315SMB 2	3GBP311220---R	2983	96,8	96,8	96,3	0,9	188	7,2	352	1,7	2,9	1,22	940	77	
132	M3BP 315SMC 2	3GBP311230---R	2982	96,9	97,0	96,8	0,9	220	7,3	423	1,9	2,7	1,44	1025	77	
160	M3BP 315MLA 2	3GBP311410---R	2983	97,0	97,1	96,8	0,9	266	8,0	512	2,2	2,8	1,7	1190	77	
200	M3BP 315MLB 2	3GBP311420---R	2983	97,2	97,3	97,2	0,9	331	7,6	640	2,6	3,0	1,89	1250	77	
200	M3BP 355SMA 2	3GBP351210---R	2987	97,2	97,1	96,6	0,9	337	8,6	639	2,0	3,7	2,73	1600	80	
250	M3BP 355SMB 2	3GBP351220---R	2984	97,2	97,2	96,8	0,9	415	8,1	800	2,2	3,3	3,1	1680	80	
315	M3BP 355SMC 2	3GBP351230---R	2985	97,2	97,2	96,9	0,9	534	7,4	1008	2,5	3,1	3,36	1750	80	
355	M3BP 355MLA 2	3GBP351410---R	2984	97,2	97,3	97,1	0,9	596	8,1	1136	2,5	2,9	3,74	2000	80	
400	M3BP 355MLB 2	3GBP351420---R	2986	97,2	97,1	96,6	0,9	669	8,6	1279	2,7	4,0	3,67	2000	85	
450	M3BP 355MLC 2	3GBP351430---R	2984	97,2	97,3	97,0	0,9	742	8,5	1440	2,6	3,6	3,91	2080	85	
500	M3BP 355LKA 2	3GBP351810---R	2980	97,2	97,3	97,2	0,9	838	8,0	1602	2,4	3,2	4,44	2340	85	
560	M3BP 400LA 2	3GBP401510---R	2989	97,2	97,1	96,5	0,9	939	7,7	1789	2,4	3,5	7,27	2950	82	
560	M3BP 400LKA 2	3GBP401810---R	2989	97,2	97,1	96,5	0,9	939	7,7	1789	2,4	3,5	7,27	2950	82	
630	M3BP 400LB 2	3GBP401520---R	2988	97,2	97,1	96,6	0,9	1052	7,9	2013	2,4	3,4	7,81	2950	82	
630	M3BP 400LKB 2	3GBP401820---R	2988	97,2	97,1	96,6	0,9	1052	7,9	2014	2,4	3,4	7,81	2950	82	
710	M3BP 400LC 2	3GBP401530---R	2988	97,2	97,2	96,7	0,9	1183	7,2	2269	2,8	3,1	8,9	3050	82	
710	M3BP 400LKC 2	3GBP401830---R	2988	97,2	97,2	96,7	0,9	1183	7,2	2269	2,8	3,1	8,9	3050	82	
800	M3BP 450LA 2	3GBP451510---R	2990	97,2	97,1	96,4	0,9	1355	7,3	2555	1,5	3,2	12	4000	85	
900	M3BP 450LB 2	3GBP451520---R	2990	97,2	97,0	96,4	0,9	1521	7,4	2874	1,8	3,1	13,3	4000	85	

Output kW	Motor type	Product code	Efficiency IEC 60034-30-1: 2014					Current			Torque			Moment of inertia J = 1/4 GD ₂ kgm ₂	Weight kg	Sound pressure Level L _{PA} dB
			Speed r/min	Full load 100%	3/4 load 75%	1/2 load 50%	Power factor Cos	I _n A	I _s /I _N	T _N Nm	T _i /T _N	T _b /T _N				
3000 r/min = 2 poles			400 V 50Hz					COMPACT-design								
110	M3BP 280MLA 2	3GBP281410---R	2984	96,8	96,7	96,1	0,9	187	9,1	352	3,1	3,8	0,941	840	73	
132	M3BP 280MLB 2	3GBP281420---R	2981	96,9	96,9	96,5	0,9	219	8,9	423	3,1	3,4	1,06	890	73	
250	M3BP 315LKB 2	3GBP311820---R	2985	97,2	97,3	97,2	0,9	414	7,8	800	3,0	3,1	2,33	1540	77	
560	M3BP 355LKB 2	3GBP351820---R	2984	97,2	97,2	96,7	0,9	918	8,7	1792	2,6	4,1	4,93	2460	85	

Technical data

IE5 cast iron motors 400 V 50 Hz

IP 55 - IC 411 - Insulation class F, temperature rise class B

IE5 efficiency class according to IEC 60034-30-1; 2014

Output kW	Motor type	Product code	Efficiency IEC 60034-30-1: 2014				Current		Torque			Moment of inertia J = 1/4 GD ₂ kgm ₂	Weight kg	Sound pressure Level L _{PA} dB	
			Speed r/min	Full load 100%	>3/4 load 75%	1/2 load 50%	Power factor Cos	I _n A	I _s /I _N	T _N Nm	T _i /T _N				T _b /T _N
1500 r/min = 4 poles			400 V 50Hz				BASIC-design								
75	M3BP 280SMC 4	3GBP282230---R	1490	96,7	96,8	96,3	0,8	139	8,6	481	3,9	3,9	1,4	725	67
75	M3BP 280SMC 4	3GBP282230---R	1490	96,7	96,8	96,5	0,8	137	8,6	481	3,6	3,6	1,4	725	67
90	M3BP 280MLD 4	3GBP282440---R	1488	96,9	97,1	97,0	0,8	159	7,9	578	3,7	3,2	1,93	910	67
110	M3BP 315SMC 4	3GBP312230---R	1491	97,0	97,1	96,8	0,9	192	7,9	705	2,9	3,3	2,52	1065	68
132	M3BP 315SMD 4	3GBP312240---R	1490	97,1	97,3	97,2	0,8	234	7,2	846	2,7	3,2	2,51	1065	68
160	M3BP 315MLC 4	3GBP312430---R	1490	97,2	97,5	97,5	0,9	276	7,5	1026	2,9	3,1	3,27	1270	68
200	M3BP 355SMB 4	3GBP352220---R	1492	97,4	97,5	97,3	0,9	343	7,5	1280	2,8	2,9	5,98	1780	66
200	M3BP 315LKC 4	3GBP312830---R	1493	97,4	97,4	97,0	0,8	350	9,1	1279	3,1	3,7	3,91	1600	72
250	M3BP 355SMC 4	3GBP352230---R	1493	97,4	97,3	96,8	0,8	448	8,2	1599	3,8	3,6	6,56	1820	70
315	M3BP 355SMD 4	3GBP352240---R	1491	97,4	97,6	97,4	0,8	558	7,0	2017	3,2	3,0	6,52	1820	70
355	M3BP 355MLA 4	3GBP352410---R	1492	97,4	97,4	97,0	0,9	619	8,2	2272	3,7	3,3	7,44	2140	78
400	M3BP 355MLB 4	3GBP352420---R	1491	97,4	97,5	97,4	0,9	696	8,2	2562	3,3	3,0	7,4	2140	78
450	M3BP 355LKA 4	3GBP352810---R	1493	97,4	97,4	97,0	0,8	798	7,4	2879	3,9	3,4	9,16	2500	78
500	M3BP 355LKB 4	3GBP352820---R	1492	97,4	97,4	97,1	0,8	885	7,0	3200	4,0	3,3	9,74	2580	78
560	M3BP 400LA 4	3GBP402510---R	1493	97,4	97,5	97,2	0,8	987	8,7	3583	3,1	3,3	12,6	3200	81
560	M3BP 400LKA 4	3GBP402810---R	1493	97,4	97,5	97,2	0,8	987	8,7	3583	3,1	3,3	12,6	3200	81
630	M3BP 400LB 4	3GBP402520---R	1491	97,4	97,6	97,4	0,9	1093	8,4	4034	2,9	3,0	13,4	3300	81
630	M3BP 400LKB 4	3GBP402820---R	1491	97,4	97,6	97,4	0,9	1093	8,4	4034	2,9	3,0	13,4	3300	81
710	M3BP 400LC 4	3GBP402530---R	1491	97,4	97,6	97,4	0,8	1247	7,2	4546	2,8	3,0	14,4	3300	81
710	M3BP 400LKC 4	3GBP402830---R	1491	97,4	97,6	97,4	0,8	1247	7,2	4546	2,8	3,0	14,4	3300	81
800	M3BP 450LA 4	3GBP452510---R	1492	97,4	97,5	97,3	0,8	1415	5,8	5121	1,4	3,0	20,8	4050	82
900	M3BP 450LB 4	3GBP452520---R	1492	97,4	97,5	97,4	0,8	1584	6,1	5761	1,4	2,9	24	4050	82
1000	M3BP 450LC 4	3GBP452530---R	1493	97,4	97,5	97,3	0,8	1778	6,8	6398	1,6	3,2	27,8	4350	82

Output kW	Motor type	Product code	Efficiency IEC 60034-30-1: 2014				Current		Torque			Moment of inertia J = 1/4 GD ₂ kgm ₂	Weight kg	Sound pressure Level L _{PA} dB	
			Speed r/min	Full load 100%	3/4 load 75%	1/2 load 50%	Power factor Cos	I _n A	I _s /I _N	T _N Nm	T _i /T _N				T _b /T _N
1500 r/min = 4 poles			400 V 50Hz				COMPACT-design								
250	M3BP 315LKD 4	3GBP312840---R	1490	97,4	97,6	97,6	0,9	434	7,5	1602	2,6	3,1	3,89	1600	72

Technical data

IE5 cast iron motors 400 V 50 Hz

IP 55 - IC 411 - Insulation class F, temperature rise class B

IE5 efficiency class according to IEC 60034-30-1; 2014

Output kW	Motor type	Product code	Efficiency IEC 60034-30-1: 2014				Current		Torque			Moment of inertia J = 1/4 GD ₂ kgm ₂	Weight kg	Sound pressure Level L _{PA} dB	
			Speed r/min	Full load 100%	>3/4 load 75%	1/2 load 50%	Power factor Cos	I _n A	I _s /I _N	T _N Nm	T _l /T _N				T _b /T _N
1000 r/min = 6 poles			400 V 50Hz				BASIC-design								
45	M3BP 280SMB 6	3GBP283220---R	992	95,8	96,1	96,0	0,8	82,6	7,5	433	2,9	2,8	1,98	680	63
45	M3BP 280SMB 6	3GBP283220---R	992	95,8	96,1	96,0	0,8	82,9	7,6	433	3,0	2,9	1,98	680	63
55	M3BP 280SMC 6	3GBP283230---R	991	96,0	96,4	96,3	0,8	100	7,4	530	3,0	2,7	2,25	725	63
55	M3BP 280SMC 6	3GBP283230---R	992	96,0	96,3	96,2	0,8	100	7,6	530	3,0	2,8	2,25	725	63
75	M3BP 315SMC 6	3GBP313230---R	994	96,3	96,4	96,1	0,8	138	7,5	720	2,7	3,0	4,34	1000	67
90	M3BP 315SMD 6	3GBP313240---R	994	96,5	96,7	96,5	0,8	165	7,4	864	2,7	2,9	4,81	1050	67
110	M3BP 315MLC 6	3GBP313430---R	994	96,6	96,7	96,3	0,8	201	7,9	1056	2,9	3,0	6,21	1280	68
132	M3BP 315LKB 6	3GBP313820---R	995	96,8	97,0	96,8	0,8	246	7,3	1267	3,2	3,1	7,32	1560	68
160	M3BP 315LKD 6	3GBP313840---R	994	96,9	97,1	96,9	0,8	299	7,1	1537	3,2	3,0	7,67	1600	68
160	M3BP 355SMB 6	3GBP353220---R	996	96,9	97,0	96,7	0,8	301	7,6	1534	2,8	3,1	9,29	1760	71
200	M3BP 355SMC 6	3GBP353230---R	995	97,0	97,2	97,0	0,8	373	7,1	1919	2,7	2,9	9,99	1830	71
250	M3BP 355MLB 6	3GBP353420---R	995	97,0	97,2	97,1	0,8	463	7,7	2400	2,8	2,8	11,9	2170	71
315	M3BP 355LKB 6	3GBP353820---R	994	97,0	97,3	97,2	0,8	574	6,3	3026	2,6	2,5	14,6	2600	73
355	M3BP 355LKC 6	3GBP353830---R	995	97,0	97,1	96,9	0,8	662	7,1	3408	3,2	2,9	16,3	2800	73
400	M3BP 400LA 6	3GBP403510---R	995	97,0	97,1	97,0	0,8	710	6,9	3840	2,6	2,9	18,9	3200	79
400	M3BP 400LKA 6	3GBP403810---R	995	97,0	97,1	97,0	0,8	710	6,9	3840	2,6	2,9	18,9	2900	79
450	M3BP 400LB 6	3GBP403520---R	996	97,0	97,1	96,7	0,8	843	7,8	4316	3,1	3,4	20,4	3300	79
450	M3BP 400LKB 6	3GBP403820---R	996	97,0	97,1	96,7	0,8	843	7,8	4316	3,1	3,4	20,4	3300	79
500	M3BP 400LC 6	3GBP403530---R	995	97,0	97,1	96,9	0,8	921	7,4	4798	3,0	3,2	20,4	3300	79
500	M3BP 400LKC 6	3GBP403830---R	995	97,0	97,1	96,9	0,8	921	7,4	4798	3,0	3,2	20,4	3300	79
560	M3BP 400LD 6	3GBP403540---R	994	97,0	97,2	97,1	0,8	997	6,9	5380	2,8	2,9	22	3400	79
560	M3BP 400LKD 6	3GBP403840---R	994	97,0	97,2	97,1	0,8	997	6,9	5380	2,8	2,9	22	3400	79
630	M3BP 450LA 6	3GBP453510---R	996	97,0	97,1	96,9	0,8	1167	7,0	6042	1,6	3,1	32,9	4250	81
710	M3BP 450LB 6	3GBP453520---R	995	97,0	97,2	97,2	0,8	1268	6,6	6815	1,5	2,8	37,5	4500	81
800	M3BP 450LC 6	3GBP453530---R	995	97,0	97,2	97,1	0,8	1453	6,2	7678	1,5	3,0	42	4800	81
900	M3BP 500LA 6	3GBP503510---R	996	97,0	96,8	96,3	0,8	1680	6,8	8628	1,4	3,9	45,6	5800	90
950	M3BP 500LB 6	3GBP503520---R	996	97,0	97,0	96,5	0,8	1709	6,6	9109	1,3	3,6	53,7	6200	90

Output kW	Motor type	Product code	Efficiency IEC 60034-30-1: 2014				Current		Torque			Moment of inertia J = 1/4 GD ₂ kgm ₂	Weight kg	Sound pressure Level L _{PA} dB	
			Speed r/min	Full load 100%	3/4 load 75%	1/2 load 50%	Power factor Cos	I _n A	I _s /I _N	T _N Nm	T _l /T _N				T _b /T _N
1000 r/min = 6 poles			400 V 50Hz				COMPACT-design								
75	M3BP 280MLD 6	3GBP283440---R	992	96,3	96,6	96,6	0,8	135	7,9	722	3,4	2,9	3,12	910	63

Technical data

IE4 cast iron motors 400 V 50 Hz

IP 55 - IC 411 - Insulation class F, temperature rise class B

IE4 efficiency class according to IEC 60034-30-1; 2014

Output kW	Motor type	Product code	Efficiency IEC 60034-30-1: 2014				Current		Torque			Moment of inertia J = 1/4 GD ₂ kgm ₂	Weight kg	Sound pressure Level L _{PA} dB	
			Speed r/min	Full load 100%	>3/4 load 75%	1/2 load 50%	Power factor Cos	I _n A	I _s /I _N	T _N Nm	T _i /T _N				T _b /T _N
3000 r/min = 2 poles			400 V 50Hz				BASIC-design								
3	M3BP 100LKA 2	3GBP101810---M	2920	89,1	88,7	86,1	0,90	5,4	9,6	10,0	3,7	5,2	0,0087	57	57
4	M3BP 112MB 2	3GBP111320---M	2882	90,0	91,3	91,7	0,91	7,1	8,8	13,4	2,4	3,9	0,0134	66	61
5.5	M3BP 132SMB 2	3GBP131220---M	2933	90,9	91,8	91,9	0,90	9,3	7,6	17,9	2,0	3,5	0,0158	85	62
7.5	M3BP 132SMC 2	3GBP131230---M	2933	91,7	92,7	92,8	0,92	13,0	9,3	24,4	2,4	4,0	0,0177	90	62
11	M3BP 160MLA 2	3GBP161410---M	2953	92,6	92,9	92,4	0,88	19,5	8,3	35,6	3,3	4,1	0,0514	141	69
15	M3BP 160MLB 2	3GBP161420---M	2955	93,3	93,5	93,0	0,88	26,4	9,0	48,5	3,8	4,4	0,0612	170	69
18.5	M3BP 160MLC 2	3GBP161430---M	2943	93,7	94,4	94,5	0,90	31,6	8,6	60,7	3,3	4,0	0,079	179	67
22	M3BP 180MLA 2	3GBP181410---M	2960	94,0	94,3	94,1	0,88	38,1	8,5	71,5	2,7	3,5	0,126	224	67
30	M3BP 200MLA 2	3GBP201410---M	2967	94,5	94,6	93,9	0,88	51,7	9,2	96,6	3,3	3,7	0,217	309	72
37	M3BP 200MLB 2	3GBP201420---M	2955	94,8	95,4	95,5	0,89	63,4	7,5	121	2,7	3,4	0,217	309	72
45	M3BP 225SMA 2	3GBP221210---M	2971	95,0	95,2	94,5	0,88	77,3	8,0	145	3,4	3,6	0,323	395	74
55	M3BP 250SMA 2	3GBP251210---M	2976	95,3	95,5	95,2	0,88	94,4	8,4	178	3,3	3,6	0,634	483	75
75	M3BP 280SMB 2	3GBP281220---M	2980	95,6	95,6	95,0	0,87	129	7,8	240	2,5	3,3	0,9	665	77
90	M3BP 280SMC 2	3GBP281230---M	2981	95,8	95,6	95,0	0,88	153	8,0	288	3,0	3,1	1,15	725	77
110	M3BP 315SMB 2	3GBP311220---M	2982	96,0	96,0	95,3	0,88	189	6,7	352	1,9	2,6	1,4	940	77
132	M3BP 315SMC 2	3GBP311230---M	2986	96,2	96,3	95,9	0,88	226	7,9	422	2,4	3,0	1,7	1025	77
160	M3BP 315MLA 2	3GBP311410---M	2983	96,3	96,5	96,3	0,90	268	7,3	512	2,2	2,7	2,1	1190	77
200	M3BP 315MLB 2	3GBP311420---M	2983	96,5	96,8	96,7	0,90	333	6,8	640	1,9	2,6	2,2	1220	77
200	M3BP 355SMA 2	3GBP351210---M	2985	96,5	96,2	95,4	0,90	336	7,6	640	2,0	3,1	3	1600	83
250	M3BP 355SMB 2	3GBP351220---M	2983	96,5	96,6	96,2	0,90	415	7,6	800	2,2	3,0	3,4	1680	83
315	M3BP 355SMC 2	3GBP351230---M	2984	96,5	96,5	95,9	0,89	533	7,8	1008	2,3	2,8	3,6	1750	83
355	M3BP 355MLA 2	3GBP351410---M	2981	96,5	96,7	96,3	0,90	595	7,5	1137	2,3	2,6	4,1	2000	83
400	M3BP 355MLB 2	3GBP351420---M	2982	96,5	96,2	95,5	0,88	677	7,1	1280	2,3	2,9	4,1	2000	83
450	M3BP 355MLC 2	3GBP351430---M	2983	96,5	96,5	95,7	0,90	743	7,9	1440	2,2	2,9	4,3	2080	83
500	M3BP 355LKA 2	3GBP351810---M	2982	96,5	96,5	96,0	0,90	827	7,5	1601	2,0	3,9	4,8	2320	83
560	M3BP 400LA 2	3GBP401510---M	2988	96,5	96,5	95,7	0,89	934	7,8	1789	2,5	3,7	7,9	2950	82
560	M3BP 400LKA 2	3GBP401810---M	2988	96,5	96,5	95,7	0,89	934	7,8	1789	2,5	3,7	7,9	2950	82
560	M3BP 355LKB 2	3GBP351820---M	2983	96,5	96,4	95,9	0,92	903	10,0	1793	2,2	4,1	5,2	2460	83
630	M3BP 400LB 2	3GBP401520---M	2987	96,5	96,2	95,6	0,89	1049	7,6	2014	2,6	3,7	8,2	2950	82
630	M3BP 400LKB 2	3GBP401820---M	2987	96,5	96,2	95,6	0,89	1049	7,6	2014	2,6	3,7	8,2	2950	82
710	M3BP 400LC 2	3GBP401530---M	2987	96,5	96,3	95,7	0,89	1178	7,2	2270	2,6	3,4	9,3	3050	82
710	M3BP 400LKC 2	3GBP401830---M	2987	96,5	96,3	95,7	0,89	1178	7,2	2270	2,6	3,4	9,3	3050	82
800	M3BP 450LA 2	3GBP451510---M	2990	96,5	96,2	95,4	0,87	1362	7,8	2555	1,3	3,4	12,2	4000	85
900	M3BP 450LB 2	3GBP451520---M	2990	96,5	96,3	95,6	0,87	1534	7,6	2874	1,5	3,1	13,5	4000	85

Output kW	Motor type	Product code	Efficiency IEC 60034-30-1: 2014				Current		Torque			Moment of inertia J = 1/4 GD ₂ kgm ₂	Weight kg	Sound pressure Level L _{PA} dB	
			Speed r/min	Full load 100%	3/4 load 75%	1/2 load 50%	Power factor Cos	I _n A	I _s /I _N	T _N Nm	T _i /T _N				T _b /T _N
3000 r/min = 2 poles			400 V 50Hz				COMPACT-design								
110	M3BP 280SMD 2	3GBP281240---M	2979	96,0	96,0	95,3	0,85	192	8,4	352	2,9	3,7	1,15	725	77
132	M3BP 280MLA 2	3GBP281410---M	2979	96,2	96,2	95,6	0,87	225	8,2	423	3,0	3,5	1,4	840	81
160	M3BP 280MLB 2	3GBP281420---M	2968	96,3	96,6	96,6	0,90	266	6,7	515	2,4	2,6	1,55	890	81
250	M3BP 315LKB 2	3GBP311820---M	2982	96,5	96,8	96,8	0,91	413	7,9	800	2,5	2,7	2,9	1540	77
315	M3BP 315LKC 2	3GBP311830---M	2981	96,5	96,6	96,2	0,89	528	8,8	1009	3,2	3,2	3,3	1630	78

Technical data

IE4 cast iron motors 400 V 50 Hz

IP 55 - IC 411 - Insulation class F, temperature rise class B

IE4 efficiency class according to IEC 60034-30-1; 2014

Output kW	Motor type	Product code	Efficiency IEC 60034-30-1: 2014				Current		Torque			Moment of inertia J = 1/4 GD ₂ kgm ₂	Weight kg	Sound pressure Level L _{PA} dB	
			Speed r/min	Full load 100%	>3/4 load 75%	1/2 load 50%	Power factor Cos	I _n A	I _s /I _N	T _N Nm	T _i /T _N				T _b /T _N
1500 r/min = 4 poles			400 V 50Hz				BASIC-design								
2.2	M3BP 100LKA 4	3GBP102810-...M	1460	89,5	89,7	89,7	0,81	4,4	7,4	14,4	2,5	3,9	0,0233	57	54
3	M3BP 100LKB 4	3GBP102820-...M	1460	90,4	90,3	90,4	0,78	6,1	8,8	19,8	3,0	3,9	0,0266	62	54
4	M3BP 112MB 4	3GBP112320-...M	1463	91,1	91,6	90,8	0,77	8,2	8,2	26,3	3,3	4,2	0,0244	70	55
5.5	M3BP 132SMB 4	3GBP132220-...M	1468	91,9	92,4	91,9	0,81	10,6	7,3	35,8	2,5	3,7	0,0425	93	60
7.5	M3BP 132SMC 4	3GBP132230-...M	1465	92,6	92,9	92,2	0,76	15,4	8,5	49,2	3,2	4,0	0,0488	101	60
11	M3BP 160MLA 4	3GBP162410-...M	1477	93,3	93,4	92,9	0,79	21,6	7,6	71,1	2,7	3,7	0,123	188	62
15	M3BP 160MLC 4	3GBP162430-...M	1478	93,9	94,1	93,2	0,76	30,3	8,3	96,9	3,5	3,9	0,127	185	62
18.5	M3BP 180MLB 4	3GBP182420-...M	1479	94,2	94,6	94,4	0,82	33,9	8,8	119	3,0	3,8	0,22	247	62
22	M3BP 180MLC 4	3GBP182430-...M	1479	94,5	94,5	93,9	0,81	40,7	9,4	142	3,2	3,9	0,22	247	62
30	M3BP 200MLA 4	3GBP202410-...M	1486	94,9	94,9	94,3	0,76	59,8	8,7	194	4,1	4,2	0,369	304	63
37	M3BP 225SMA 4	3GBP222210-...M	1480	95,2	95,7	95,6	0,84	66,8	7,5	239	3,1	3,2	0,536	383	66
45	M3BP 225SMC 4	3GBP222230-...M	1484	95,4	95,7	95,5	0,82	83,4	8,5	290	3,6	3,8	0,607	433	66
55	M3BP 250SMA 4	3GBP252210-...M	1483	95,7	95,8	95,4	0,83	100	7,8	354	3,3	3,6	0,933	467	67
75	M3BP 280SMC 4	3GBP282230-...M	1487	96,0	96,4	96,1	0,86	130	7,8	481	2,8	2,9	1,85	725	72
90	M3BP 280MLA 4	3GBP282410-...M	1489	96,1	96,5	96,4	0,85	160	8,8	577	3,4	3,2	2,3	840	72
110	M3BP 315SMC 4	3GBP312230-...M	1491	96,3	96,5	96,1	0,85	194	7,8	704	2,4	3,1	2,9	1000	68
132	M3BP 315SMD 4	3GBP312240-...M	1490	96,4	96,6	96,2	0,85	234	7,9	846	2,6	3,2	3,2	1065	68
160	M3BP 315MLB 4	3GBP312420-...M	1490	96,6	96,8	96,4	0,86	278	7,9	1026	2,7	3,0	3,9	1220	68
200	M3BP 355SMA 4	3GBP352210-...M	1491	96,7	96,8	96,4	0,87	345	7,3	1282	2,1	2,7	5,9	1610	74
250	M3BP 355SMB 4	3GBP352220-...M	1491	96,7	96,8	96,5	0,87	433	7,8	1601	2,5	2,9	6,9	1780	74
315	M3BP 355SMC 4	3GBP352230-...M	1490	96,7	96,8	96,5	0,86	554	7,4	2017	2,4	2,9	7,2	1820	74
355	M3BP 355MLA 4	3GBP352410-...M	1491	96,7	96,9	96,5	0,87	616	7,9	2274	2,7	2,9	8,4	2140	78
400	M3BP 355MLB 4	3GBP352420-...M	1490	96,7	96,7	96,4	0,85	700	6,8	2563	2,1	2,8	8,4	2140	78
450	M3BP 355MLC 4	3GBP352430-...M	1489	96,7	96,8	96,5	0,86	779	6,8	2886	2,4	2,8	8,4	2140	78
500	M3BP 355LKA 4	3GBP352810-...M	1490	96,7	96,7	96,1	0,86	865	6,8	3204	2,0	3,0	10	2500	78
560	M3BP 400LA 4	3GBP402510-...M	1491	96,7	96,7	96,3	0,85	982	7,4	3586	2,4	2,8	15	3200	78
560	M3BP 400LKA 4	3GBP402810-...M	1491	96,7	96,7	96,3	0,85	982	7,4	3586	2,4	2,8	15	3200	78
630	M3BP 400LB 4	3GBP402520-...M	1491	96,7	96,7	96,2	0,86	1091	7,6	4034	2,2	2,9	16	3300	78
630	M3BP 400LKB 4	3GBP402820-...M	1491	96,7	96,7	96,2	0,86	1091	7,6	4034	2,2	2,9	16	3300	78
710	M3BP 400LC 4	3GBP402530-...M	1491	96,7	96,7	96,2	0,84	1245	7,6	4547	2,4	3,0	17	3300	78
710	M3BP 400LKC 4	3GBP402830-...M	1491	96,7	96,7	96,2	0,84	1227	7,6	4547	2,4	3,0	17	3300	78
800	M3BP 450LA 4	3GBP452510-...M	1491	96,7	96,7	96,2	0,86	1388	7,0	5121	1,3	2,8	23	4050	85
900	M3BP 450LB 4	3GBP452520-...M	1491	96,7	96,5	96,0	0,85	1575	7,0	5761	1,3	2,8	25	4050	85
1000	M3BP 450LC 4	3GBP452530-...M	1491	96,7	96,7	96,1	0,86	1724	6,8	6404	1,3	2,7	30	4350	85
1100	M3BP 500LA 4	3GBP502510-...M	1494	97,5	97,4	96,9	0,85	1916	7,0	7031	1,0	3,1	35,1	5900	86

Output kW	Motor type	Product code	Efficiency IEC 60034-30-1: 2014				Current		Torque			Moment of inertia J = 1/4 GD ₂ kgm ₂	Weight kg	Sound pressure Level L _{PA} dB	
			Speed r/min	Full load 100%	3/4 load 75%	1/2 load 50%	Power factor Cos	I _n A	I _s /I _N	T _N Nm	T _i /T _N				T _b /T _N
1500 r/min = 4 poles			400 V 50Hz				COMPACT-design								
110	M3BP 280MLB 4	3GBP282420-...M	1489	96,3	96,3	95,7	0,80	205	8,8	706	4,0	4,0	2,5	890	75
132	M3BP 280MLC 4	3GBP282430-...M	1489	96,4	96,4	95,8	0,80	247	8,3	846	3,5	4,1	2,5	890	75
200	M3BP 315LKB 4	3GBP312820-...M	1490	96,7	96,9	96,8	0,87	346	7,6	1282	2,5	2,9	5	1480	74
250	M3BP 315LKC 4	3GBP312830-...M	1490	96,7	96,9	96,8	0,87	432	7,8	1601	2,3	3,0	5,5	1600	74
315	M3BP 315LKE 4	3GBP312850-...M	1488	96,7	97,0	97,0	0,84	558	7,3	2029	2,5	3,1	4,6	1540	72

Technical data

IE4 cast iron motors 400 V 50 Hz

IP 55 - IC 411 - Insulation class F, temperature rise class B

IE4 efficiency class according to IEC 60034-30-1; 2014

Output kW	Motor type	Product code	Efficiency IEC 60034-30-1: 2014				Current		Torque			Moment of inertia J = 1/4 GD ₂ kgm ₂	Weight kg	Sound pressure Level L _{PA} dB	
			Speed r/min	Full load 100%	>3/4 load 75%	1/2 load 50%	Power factor Cos	I _n A	I _s /I _N	T _N Nm	T _i /T _N				T _b /T _N
1000 r/min = 6 poles			400 V 50Hz				BASIC-design								
1.5	M3BP 100LKB 6	3GBP103820---M	972	85,9	85,8	83,7	0,73	3,3	6,2	14,7	2,1	3,5	0,0159	51	49
2.2	M3BP 112MB 6	3GBP113320---M	973	87,4	87,9	87,0	0,71	5,0	6,8	21,4	2,3	3,4	0,0198	63	55
3	M3BP 132SMB 6	3GBP133220---M	979	88,6	89,1	88,1	0,80	5,9	5,7	29,3	1,5	2,9	0,0347	85	64
4	M3BP 132SMC 6	3GBP133230---M	978	89,5	90,0	89,3	0,80	7,9	5,6	39,1	1,5	2,8	0,0385	90	64
5.5	M3BP 132SMD 6	3GBP133240---M	973	90,5	91,3	91,1	0,75	11,7	5,8	54,0	1,7	2,8	0,0422	97	64
7.5	M3BP 160MLA 6	3GBP163410---M	984	91,3	91,0	89,4	0,75	15,8	8,0	72,8	2,2	3,6	0,133	187	59
11	M3BP 160MLB 6	3GBP163420---M	980	92,3	92,3	91,7	0,76	22,8	7,3	107	1,9	3,4	0,133	189	59
15	M3BP 180MLA 6	3GBP183410---M	985	92,9	92,8	91,8	0,72	32,1	7,4	147	2,8	3,8	0,254	240	59
18.5	M3BP 200MLA 6	3GBP203410---M	991	93,4	93,7	93,2	0,80	35,7	8,1	178	3,0	3,6	0,531	306	63
22	M3BP 200MLC 6	3GBP203430---M	990	93,7	93,7	93,2	0,77	44,3	8,6	212	3,0	3,8	0,545	311	63
30	M3BP 225SMA 6	3GBP223210---M	988	94,2	94,5	94,1	0,78	59,2	7,3	290	3,0	3,4	0,813	369	63
37	M3BP 250SMA 6	3GBP253210---M	992	94,5	94,9	94,8	0,76	74,0	8,6	357	3,7	3,7	1,49	457	63
45	M3BP 280SMB 6	3GBP283220---M	992	94,8	95,1	94,6	0,85	80,9	7,5	434	2,4	2,6	2,2	680	65
55	M3BP 280SMC 6	3GBP283230---M	990	95,1	95,4	95,1	0,85	99,4	6,8	506	2,4	2,6	2,85	725	65
75	M3BP 315SMC 6	3GBP313230---M	994	95,4	95,6	95,2	0,83	138	7,0	721	2,2	2,8	4,9	1000	67
90	M3BP 315SMD 6	3GBP313240---M	994	95,6	95,8	95,4	0,81	170	7,2	864	2,4	2,9	4,9	1040	67
110	M3BP 315MLB 6	3GBP313420---M	994	95,8	96,0	95,8	0,83	202	6,9	1057	2,3	2,7	6,3	1200	68
132	M3BP 315LKA 6	3GBP313810---M	993	96,0	96,2	96,0	0,82	243	6,9	1269	2,4	2,7	7,3	1410	68
160	M3BP 355SMB 6	3GBP353220---M	995	96,2	96,2	95,7	0,82	294	7,0	1536	2,1	2,7	9,7	1680	73
200	M3BP 355SMC 6	3GBP353230---M	995	96,3	96,5	96,1	0,82	367	7,3	1920	2,3	2,8	11,3	1820	73
250	M3BP 355MLB 6	3GBP353420---M	995	96,5	96,7	96,6	0,83	456	7,1	2399	2,3	2,7	13,5	2180	73
315	M3BP 355LKA 6	3GBP353810---M	994	96,6	96,7	96,5	0,83	576	6,9	3026	2,3	2,6	15,5	2500	76
355	M3BP 355LKB 6	3GBP353820---M	995	96,6	96,6	96,0	0,81	668	7,7	3407	2,7	2,9	16,5	2600	76
400	M3BP 400LA 6	3GBP403510---M	994	96,6	96,7	96,3	0,80	747	7,5	3843	2,8	3,1	17	2900	76
400	M3BP 400LKA 6	3GBP403810---M	994	96,6	96,7	96,3	0,80	747	7,5	3843	2,8	3,1	17	2900	76
450	M3BP 400LB 6	3GBP403520---M	995	96,6	96,5	95,7	0,81	830	8,3	4319	3,4	3,6	22	3300	76
450	M3BP 400LKB 6	3GBP403820---M	995	96,6	96,5	95,7	0,81	830	8,3	4319	3,4	3,6	22	3300	76
500	M3BP 400LC 6	3GBP403530---M	995	96,6	96,5	95,9	0,82	911	7,8	4799	3,2	3,4	22	3300	76
500	M3BP 400LKC 6	3GBP403830---M	995	96,6	96,5	95,9	0,82	911	7,8	4799	3,2	3,4	22	3300	76
560	M3BP 400LD 6	3GBP403540---M	993	96,6	96,6	96,1	0,85	984	7,4	5386	2,4	2,8	24	3400	77
560	M3BP 400LKD 6	3GBP403840---M	993	96,6	96,6	96,1	0,85	984	7,4	5386	2,4	2,8	24	3400	77
630	M3BP 450LA 6	3GBP453510---M	995	96,6	96,6	95,9	0,82	1146	7,5	6046	1,4	3,2	31	4150	81
710	M3BP 450LB 6	3GBP453520---M	995	96,6	96,7	96,2	0,85	1244	7,0	6814	1,3	2,5	37	4500	81
800	M3BP 450LC 6	3GBP453530---M	995	96,6	96,6	96,1	0,84	1415	7,2	7677	1,3	2,7	41	4800	81
900	M3BP 500LA 6	3GBP503510---M	996	96,6	96,5	95,9	0,80	1670	6,3	8629	1,3	3,6	50,8	5800	90
950	M3BP 500LB 6	3GBP503520---M	996	96,6	96,4	95,9	0,80	1760	6,7	9109	1,4	3,8	59,6	6200	90

Output kW	Motor type	Product code	Efficiency IEC 60034-30-1: 2014				Current		Torque			Moment of inertia J = 1/4 GD ₂ kgm ₂	Weight kg	Sound pressure Level L _{PA} dB	
			Speed r/min	Full load 100%	3/4 load 75%	1/2 load 50%	Power factor Cos	I _n A	I _s /I _N	T _N Nm	T _i /T _N				T _b /T _N
1000 r/min = 6 poles			400 V 50Hz				COMPACT-design								
75	M3BP 280SMD 6	3GBP283240---M	990	95,4	95,7	95,5	0,81	141	7,0	726	2,8	2,8	2,5	730	65
160	M3BP 315LKC 6	3GBP313830---M	994	96,2	96,4	96,3	0,82	297	7,4	1537	2,7	2,9	9,2	1600	68
200	M3BP 315LKE 6	3GBP313850---M	993	96,3	96,5	96,2	0,81	372	7,0	1923	2,2	2,8	9,2	1600	76

Technical data

IE3 cast iron motors 400 V 50 Hz

IP 55 - IC 411 - Insulation class F, temperature rise class B

IE3 efficiency class according to IEC 60034-30-1; 2014

Output kW	Motor type	Product code	Efficiency IEC 60034-30-1: 2014				Current		Torque			Moment of inertia J = 1/4 GD ₂ kgm ₂	Weight kg	Sound pressure Level L _{PA} dB	
			Speed r/min	Full load 100%	>3/4 load 75%	1/2 load 50%	Power factor Cos	I _n A	I _s /I _N	T _N Nm	T _i /T _N				T _b /T _N
3000 r/min = 2 poles			400 V 50Hz				BASIC-design								
0.55	M3BP 71ME 2	3GBP071350---K	2755	77,8	79,6	78,8	0,83	1,25	6,8	1,90	2,8	3,1	0,00045	11	56
0.75	M3BP 80MD 2	3GBP081340---K	2894	80,7	80,4	77,2	0,74	1,70	7,9	2,4	3,7	4,2	0,0008	18	57
1.1	M3BP 80MG 2	3GBP081370---K	2855	82,7	82,4	80,6	0,78	2,5	7,9	3,6	3,7	4,2	0,001	19	56
1.5	M3BP 90LB 2	3GBP091520---K	2906	84,2	84,8	84,7	0,89	2,8	7,9	4,9	2,6	3,3	0,0027	31	60
2.2	M3BP 90LC 2	3GBP091530---K	2900	85,9	87,5	87,6	0,89	4,0	8,3	7,2	2,9	3,5	0,0032	35	60
3	M3BP 100LKA 2	3GBP101810---K	2896	87,1	88,1	87,9	0,90	5,4	8,4	9,8	3,2	3,9	0,0057	50	62
4	M3BP 112MG 2	3GBP111370---K	2888	88,1	89,4	89,6	0,91	7,1	8,4	13,2	3,2	4,0	0,0104	56	68
5.5	M3BP 132SMF 2	3GBP131260---K	2901	89,2	89,9	90,1	0,91	9,7	7,9	18,1	2,3	3,4	0,0154	77	68
7.5	M3BP 132SMG 2	3GBP131270---K	2909	90,1	91,2	91,4	0,90	13,1	8,3	24,6	3,0	3,9	0,0173	77	70
11	M3BP 160MLA 2	3GBP161410---K	2943	91,2	91,9	91,6	0,91	19,1	7,2	35,6	2,6	3,3	0,057	141	69
15	M3BP 160MLB 2	3GBP161420---K	2947	91,9	92,2	91,8	0,88	26,5	8,2	48,5	3,0	3,8	0,063	170	69
18.5	M3BP 160MLC 2	3GBP161430---K	2949	92,4	93,0	92,6	0,90	32,0	9,0	59,8	3,3	3,9	0,076	183	73
22	M3BP 180MLA 2	3GBP181410---K	2956	92,7	93,1	92,7	0,90	37,7	7,8	71,0	3,0	3,8	0,11	205	73
30	M3BP 200MLA 2	3GBP201410---K	2962	93,3	93,5	92,8	0,87	53,2	7,6	96,8	3,1	3,3	0,159	289	77
37	M3BP 200MLB 2	3GBP201420---K	2959	93,7	93,7	92,7	0,90	63,5	8,2	119	3,0	3,3	0,196	314	72
45	M3BP 225SMA 2	3GBP221210---K	2968	94,0	94,0	93,0	0,87	79,6	7,3	145	2,7	3,1	0,296	335	76
55	M3BP 250SMA 2	3GBP251210---K	2968	94,3	94,4	93,6	0,89	94,8	6,8	177	2,4	3,0	0,426	452	76
250	M3BP 355SMB 2	3GBP351220---K	2984	95,8	95,5	94,5	0,89	423	7,7	800	2,1	3,3	3	1680	83
315	M3BP 355SMC 2	3GBP351230---K	2980	95,8	95,7	95,0	0,89	531	7,0	1009	2,1	3,0	3,4	1750	83
355	M3BP 355MLA 2	3GBP351410---K	2984	95,8	95,8	94,9	0,88	603	7,2	1136	2,2	3,0	3,6	2000	83
400	M3BP 355MLB 2	3GBP351420---K	2982	95,8	95,6	94,7	0,88	677	7,1	1280	2,3	2,9	4,1	2000	83
450	M3BP 355MLC 2	3GBP351430---K	2983	95,8	95,8	95,0	0,90	743	7,9	1440	2,2	2,9	4,3	2080	83
500	M3BP 355LKA 2	3GBP351810---K	2982	95,8	95,8	95,3	0,90	827	7,5	1601	2,0	3,9	4,8	2320	83
560	M3BP 400LA 2	3GBP401510---K	2988	95,8	95,8	94,9	0,89	934	7,8	1789	2,5	3,7	7,9	2950	82
560	M3BP 400LKA 2	3GBP401810---K	2988	95,8	95,8	94,9	0,89	934	7,8	1789	2,5	3,7	7,9	2950	82
560	M3BP 355LKB 2	3GBP351820---K	2983	95,8	95,8	95,1	0,90	925	8,0	1792	2,2	4,1	5,2	2460	83
630	M3BP 400LB 2	3GBP401520---K	2987	95,8	95,5	94,8	0,89	1049	7,6	2014	2,6	3,7	8,2	3050	82
630	M3BP 400LKB 2	3GBP401820---K	2987	95,8	95,5	94,8	0,89	1049	7,6	2014	2,6	3,7	8,2	3050	82
710	M3BP 400LC 2	3GBP401530---K	2987	95,8	95,7	94,9	0,89	1178	7,2	2270	2,6	3,4	9,3	3300	82
710	M3BP 400LKC 2	3GBP401830---K	2987	95,8	95,7	94,9	0,89	1178	7,2	2270	2,6	3,4	9,3	3300	82
800	M3BP 450LA 2	3GBP451510---K	2990	95,8	95,5	94,5	0,87	1362	7,8	2555	1,3	3,4	12,2	4000	85
900	M3BP 450LB 2	3GBP451520---K	2990	95,8	95,5	94,7	0,87	1534	7,6	2874	1,5	3,1	13,5	4200	85

Output kW	Motor type	Product code	Efficiency IEC 60034-30-1: 2014				Current		Torque			Moment of inertia J = 1/4 GD ₂ kgm ₂	Weight kg	Sound pressure Level L _{PA} dB	
			Speed r/min	Full load 100%	3/4 load 75%	1/2 load 50%	Power factor Cos	I _n A	I _s /I _N	T _N Nm	T _i /T _N				T _b /T _N
3000 r/min = 2 poles			400 V 50Hz				COMPACT-design								
22	M3BP 160MLD 2	3GBP161440---K	2944	92,7	93,5	93,5	0,90	38,0	8,4	71,4	3,2	3,7	0,071	174	74
30	M3BP 180MLB 2	3GBP181420---K	2957	93,3	94,0	93,9	0,88	52,7	8,7	96,9	3,0	3,8	0,104	215	74
37	M3BP 180MLC 2	3GBP181430---K	2950	93,7	94,2	94,2	0,86	66,0	8,5	120	3,4	4,4	0,117	229	74
45	M3BP 200MLC 2	3GBP201430---K	2956	94,0	94,6	94,8	0,89	77,2	7,8	145	2,9	3,3	0,216	305	77
55	M3BP 225SMB 2	3GBP221220---K	2964	94,3	94,4	93,9	0,86	97,4	7,2	177	3,1	3,2	0,299	355	79
250	M3BP 315LKB 2	3GBP311820---K	2982	95,8	95,8	95,2	0,91	412	7,7	800	2,5	3,3	2,6	1540	81
315	M3BP 315LKC 2	3GBP311830---K	2981	95,8	95,9	95,4	0,89	528	8,8	1009	3,2	3,2	3,3	1630	78

Technical data

IE3 cast iron motors 400 V 50 Hz

IP 55 - IC 411 - Insulation class F, temperature rise class B

IE3 efficiency class according to IEC 60034-30-1; 2014

Output kW	Motor type	Product code	Efficiency IEC 60034-30-1: 2014				Current		Torque			Moment of inertia J = 1/4 GD ₂ kgm ₂	Weight kg	Sound pressure Level L _{PA} dB	
			Speed r/min	Full load 100%	>3/4 load 75%	1/2 load 50%	Power factor Cos	I _n A	I _s /I _N	T _N Nm	T _i /T _N				T _b /T _N
1500 r/min = 4 poles			400 V 50Hz				BASIC-design								
0.25	M3BP 71MD 4	3GBP072340---K	1416	73,5	75,1	73,8	0,80	0,60	4,8	1,68	2,0	2,6	0,0009	11	45
0.37	M3BP 71MLE 4	3GBP072450---K	1432	77,3	77,4	74,5	0,76	0,90	5,8	2,5	2,7	3,3	0,00122	15	45
0.55	M3BP 80MLD 4	3GBP082440---K	1439	80,8	82,2	81,4	0,81	1,18	6,3	3,6	2,3	3,3	0,0028	20	45
0.75	M3BP 90L 4	3GBP092500---K	1448	82,5	82,9	81,4	0,78	1,62	8,0	5,0	3,9	4,4	0,0056	30	53
0.75	M3BP 80MLG 4	3GBP082470---K	1440	82,5	82,4	80,2	0,76	1,68	7,9	4,9	2,9	3,7	0,0027	22	54
1.1	M3BP 90LC 4	3GBP092530---K	1442	84,1	83,5	81,7	0,80	2,3	7,9	7,2	3,3	3,9	0,0055	33	56
1.5	M3BP 90LD 4	3GBP092540---K	1439	85,3	84,7	82,8	0,78	3,2	8,2	9,9	3,5	4,0	0,0055	34	55
2.2	M3BP 100LKA 4	3GBP102810---K	1454	86,7	87,2	86,1	0,83	4,3	8,9	14,5	3,1	4,1	0,0144	49	54
3	M3BP 100LKB 4	3GBP102820---K	1452	87,7	88,1	87,1	0,83	5,9	9,0	19,7	3,5	4,2	0,0144	49	54
4	M3BP 112MG 4	3GBP112370---K	1451	88,6	89,5	89,0	0,77	8,6	7,6	26,3	3,1	4,1	0,018	52	64
5.5	M3BP 132SMF 4	3GBP132260---K	1462	89,6	90,6	90,6	0,81	10,8	7,3	35,9	2,4	3,4	0,0401	87	67
7.5	M3BP 132SMG 4	3GBP132270---K	1464	90,4	90,8	90,7	0,81	14,7	7,7	48,9	2,5	3,6	0,0414	81	64
11	M3BP 160MLA 4	3GBP162410---K	1477	91,4	91,8	91,1	0,82	21,1	7,6	71,3	2,6	3,3	0,11	188	61
15	M3BP 160MLB 4	3GBP162420---K	1477	92,1	92,4	91,6	0,82	28,5	8,2	97,0	3,0	3,7	0,135	187	61
18.5	M3BP 180MLA 4	3GBP182410---K	1481	92,6	93,2	92,9	0,83	34,9	7,2	119	2,8	3,0	0,219	235	60
22	M3BP 180MLB 4	3GBP182420---K	1480	93,0	93,5	93,2	0,82	41,5	8,2	141	2,8	3,1	0,217	235	62
30	M3BP 200MLA 4	3GBP202410---K	1483	93,6	93,9	93,4	0,84	54,8	7,5	193	2,8	3,0	0,385	319	63
37	M3BP 225SMA 4	3GBP222210---K	1481	93,9	94,1	93,4	0,82	69,8	8,0	235	3,3	3,5	0,433	398	75
45	M3BP 225SMB 4	3GBP222220---K	1482	94,2	94,4	94,0	0,84	82,3	8,0	290	3,2	3,5	0,525	398	66
55	M3BP 250SMA 4	3GBP252210---K	1485	94,6	95,2	94,9	0,85	97,8	7,9	353	3,0	3,3	0,933	476	67
250	M3BP 355SMB 4	3GBP352220---K	1491	96,0	96,0	95,5	0,86	435	6,4	1 601	2,1	2,9	5,7	1780	78
315	M3BP 355SMC 4	3GBP352230---K	1491	96,0	96,1	95,7	0,85	550	7,3	2 018	2,4	3,3	6,7	1820	78
355	M3BP 355MLA 4	3GBP352410---K	1490	96,0	96,2	95,8	0,86	616	6,3	2 273	2,3	2,8	7,2	2140	78
400	M3BP 355MLB 4	3GBP352420---K	1489	96,0	96,0	95,5	0,85	705	6,8	2 565	2,3	2,6	8,4	2140	78
450	M3BP 355MLC 4	3GBP352430---K	1490	96,0	96,1	95,6	0,86	780	6,9	2 884	2,3	2,9	8,4	2140	78
500	M3BP 355LKA 4	3GBP352810---K	1490	96,0	96,0	95,3	0,86	865	6,8	3 204	2,0	3,0	10	2500	78
560	M3BP 355LKB 4	3GBP352820---K	1490	96,0	96,0	95,5	0,85	981	7,2	3 588	2,6	2,7	10,6	2600	78
560	M3BP 400LA 4	3GBP402510---K	1491	96,0	96,0	95,4	0,85	982	7,4	3 586	2,4	2,8	15	3200	78
560	M3BP 400LKA 4	3GBP402810---K	1491	96,0	96,0	95,4	0,85	982	7,4	3 586	2,4	2,8	15	3200	78
630	M3BP 400LB 4	3GBP402520---K	1491	96,0	96,0	95,4	0,86	1077	7,6	4 034	2,2	2,9	16	3300	78
630	M3BP 400LKB 4	3GBP402820---K	1491	96,0	96,0	95,4	0,86	1077	7,6	4 034	2,2	2,9	16	3300	78
710	M3BP 400LC 4	3GBP402530---K	1491	96,0	96,0	95,5	0,85	1227	7,6	4 547	2,4	3,0	17	3400	78
710	M3BP 400LKC 4	3GBP402830---K	1491	96,0	96,0	95,5	0,85	1227	7,6	4 547	2,4	3,0	17	3400	78
800	M3BP 450LA 4	3GBP452510---K	1491	96,0	96,0	95,4	0,86	1396	7,0	5 121	1,3	2,8	23	4050	85
900	M3BP 450LB 4	3GBP452520---K	1492	96,0	95,9	95,2	0,86	1573	7,0	5 761	1,3	2,8	25	4350	85
1000	M3BP 450LC 4	3GBP452530---K	1491	96,0	96,0	95,3	0,86	1724	6,8	6 404	1,3	2,7	30	4700	85

Output kW	Motor type	Product code	Efficiency IEC 60034-30-1: 2014				Current		Torque			Moment of inertia J = 1/4 GD ₂ kgm ₂	Weight kg	Sound pressure Level L _{PA} dB	
			Speed r/min	Full load 100%	3/4 load 75%	1/2 load 50%	Power factor Cos	I _n A	I _s /I _N	T _N Nm	T _i /T _N				T _b /T _N
1500 r/min = 4 poles			400 V 50Hz				COMPACT-design								
18.5	M3BP 160MLC 4	3GBP162430---K	1476	92,6	93,1	92,7	0,77	37,2	8,3	120	3,3	3,6	0,121	180	67
28	M3BP 180MLC 4	3GBP182430---K	1482	93,4	93,3	92,3	0,77	56,5	8,2	180	3,0	3,6	0,191	235	62
37	M3BP 200MLB 4	3GBP202420---K	1482	93,9	94,1	93,7	0,82	69,3	7,8	238	3,1	3,3	0,362	305	68
45	M3BP 225SMC 4	3GBP222230---K	1486	94,7	94,7	93,8	0,80	85,0	10,0	341	3,7	4,0	0,532	391	71
53	M3BP 225SMC 4	3GBP222230---K	1483	94,5	94,7	94,2	0,83	97,0	8,7	341	3,2	3,4	0,532	391	71
250	M3BP 315LKC 4	3GBP312830---K	1488	96,0	96,2	96,0	0,84	445	7,7	1604	2,5	3,2	4,4	1460	78
280	M3BP 315LKD 4	3GBP312840---K	1488	96,0	96,2	96,0	0,86	490	7,8	1797	2,7	3,1	5	1520	78
315	M3BP 315LKE 4	3GBP312850---K	1489	96,0	96,2	96,1	0,84	558	8,3	2020	3,0	3,3	5,5	1600	78

Technical data

IE3 cast iron motors 400 V 50 Hz

IP 55 - IC 411 - Insulation class F, temperature rise class B

IE3 efficiency class according to IEC 60034-30-1; 2014

Output kW	Motor type	Product code	Efficiency IEC 60034-30-1: 2014					Current		Torque			Moment of inertia J = 1/4 GD ₂ kgm ₂	Weight kg	Sound pressure Level L _{PA} dB	
			Speed r/min	Full load 100%	>3/4 load 75%	1/2 load 50%	Power factor Cos	I _n A	I _s /I _N	T _N Nm	T _l /T _N	T _b /T _N				
1000 r/min = 6 poles			400 V 50Hz					BASIC-design								
0.37	M3BP 80MD 6	3GBP083340---K	930	73,5	74,3	72,0	0,67	1,00	4,6	3,8	2,8	3,2	0,0028	16	47	
0.75	M3BP 90LG 6	3GBP093570---K	938	78,9	80,4	79,7	0,74	1,80	4,8	7,7	2,4	2,7	0,0072	34	44	
1.1	M3BP 90LH 6	3GBP093580---K	944	81,0	81,7	80,1	0,75	2,6	4,7	11,1	2,1	2,8	0,0068	33	44	
1.1	M3BP 100LKG 6	3GBP103870---K	969	81,0	81,1	79,0	0,68	2,6	5,9	10,9	2,0	2,2	0,0025	47	49	
1.5	M3BP 100LKH 6	3GBP103880---K	969	82,5	81,5	77,6	0,66	3,8	7,0	14,8	3,3	4,1	0,0138	47	49	
1.5	M3BP 112MH 6	3GBP113380---K	972	82,5	82,2	79,6	0,64	3,8	7,0	14,7	2,7	4,3	0,0196	53	66	
2.2	M3BP 132SMC 6	3GBP132320---K	978	84,3	84,4	82,7	0,69	5,1	5,4	21,5	2,0	2,6	0,0416	81	57	
2.2	M3BP 112MJ 6	3GBP113390---K	967	84,3	85,2	84,1	0,69	5,2	6,5	21,7	2,4	3,5	0,0187	53	68	
3	M3BP 132SMD 6	3GBP132340---K	977	85,6	85,9	84,3	0,69	6,9	5,9	29,0	1,9	3,3	0,0416	82	57	
4	M3BP 132SMG 6	3GBP132370---K	974	86,8	87,4	86,6	0,69	9,3	5,6	38,7	1,8	2,8	0,0416	82	57	
5.5	M3BP 132SMH 6	3GBP132380---K	966	88,0	88,9	88,7	0,73	12,1	5,0	54,1	1,8	2,7	0,0654	79	57	
7.5	M3BP 160MLA 6	3GBP163410---K	980	89,1	89,9	89,3	0,78	15,2	7,9	73,0	1,7	2,8	0,114	172	59	
11	M3BP 160MLB 6	3GBP163420---K	979	90,3	90,9	90,2	0,74	23,5	8,5	107	2,2	3,9	0,131	199	59	
15	M3BP 180MLA 6	3GBP183410---K	981	91,2	91,5	90,4	0,77	30,4	5,5	146	1,7	2,7	0,225	234	59	
18.5	M3BP 200MLA 6	3GBP203410---K	990	91,7	92,1	91,4	0,77	37,3	7,5	178	2,6	3,2	0,448	291	63	
22	M3BP 200MLB 6	3GBP203420---K	990	92,2	92,6	91,9	0,79	43,0	7,8	212	2,6	3,2	0,531	318	63	
30	M3BP 225SMA 6	3GBP223210---K	989	92,9	93,5	93,3	0,81	56,8	7,9	289	2,8	3,1	0,813	392	63	
37	M3BP 250SMA 6	3GBP253210---K	991	93,3	93,8	93,6	0,83	68,0	7,7	356	2,7	2,9	1,49	467	63	
45	M3BP 280SMB 6	3GBP283220---K	991	93,7	94,0	93,5	0,84	82,0	7,4	433	2,7	3,0	1,87	645	72	
55	M3BP 280SMC 6	3GBP283230---K	992	94,1	94,3	93,9	0,86	99,0	7,5	528	2,8	3,0	2,57	700	71	
250	M3BP 355MLB 6	3GBP353420---K	993	95,8	95,9	95,5	0,82	460	7,4	2404	2,6	2,9	11,3	2010	75	
315	M3BP 355LKA 6	3GBP353810---K	992	95,8	96,0	95,6	0,83	570	7,0	3032	2,5	2,7	14,6	2390	78	
355	M3BP 355LKB 6	3GBP353820---K	992	95,8	95,9	95,4	0,82	648	7,7	3417	2,9	3,5	15,5	2540	75	
400	M3BP 355LKC 6	3GBP353830---K	992	96,0	96,0	95,5	0,83	724	7,2	3850	2,6	2,6	16,5	2600	75	
400	M3BP 400LA 6	3GBP403510---K	993	95,8	95,8	95,1	0,82	731	7,1	3846	2,3	2,7	17	2900	76	
400	M3BP 400LKA 6	3GBP403810---K	993	95,8	95,8	95,1	0,82	731	7,1	3846	2,3	2,7	17	2900	76	
450	M3BP 400LB 6	3GBP403520---K	994	95,8	95,8	95,2	0,82	819	7,4	4323	2,4	2,5	20,5	3150	76	
450	M3BP 400LKB 6	3GBP403820---K	994	95,8	95,8	95,2	0,82	819	7,4	4323	2,4	2,5	20,5	3150	76	
500	M3BP 400LC 6	3GBP403530---K	993	95,8	95,6	95,2	0,83	891	7,2	4809	2,5	2,7	22	3300	76	
500	M3BP 400LKC 6	3GBP403830---K	993	95,8	95,6	95,2	0,83	891	7,2	4809	2,5	2,7	22	3300	76	
500	M3BP 400LKC 6	3GBP403830---K	993	95,8	95,6	95,2	0,83	891	7,2	4809	2,5	2,7	22	3300	76	
560	M3BP 400LD 6	3GBP403540---K	993	95,8	95,8	95,2	0,85	984	7,4	5386	2,4	2,8	24	3400	77	
560	M3BP 400LKD 6	3GBP403840---K	993	95,8	95,8	95,2	0,85	984	7,4	5386	2,4	2,8	24	3400	77	
630	M3BP 450LA 6	3GBP453510---K	994	95,8	95,9	95,3	0,84	1127	6,5	6053	1,1	2,5	31	4150	81	
710	M3BP 450LB 6	3GBP453520---K	995	95,8	95,9	95,3	0,85	1244	7,0	6814	1,3	2,5	37	4500	81	
800	M3BP 450LC 6	3GBP453530---K	995	95,8	95,8	95,1	0,84	1415	7,2	7677	1,3	2,7	41	4800	81	

Output kW	Motor type	Product code	Efficiency IEC 60034-30-1: 2014					Current		Torque			Moment of inertia J = 1/4 GD ₂ kgm ₂	Weight kg	Sound pressure Level L _{PA} dB	
			Speed r/min	Full load 100%	3/4 load 75%	1/2 load 50%	Power factor Cos	I _n A	I _s /I _N	T _N Nm	T _l /T _N	T _b /T _N				
1000 r/min = 6 poles			400 V 50Hz					COMPACT-design								
18.5	M3BP 180MLB 6	3GBP183420---K	980	91,7	92,1	91,5	0,72	40,3	6,8	180	2,3	3,2	0,191	219	65	
37	M3BP 225SMB 6	3GBP223220---K	986	93,3	93,6	93,0	0,76	75,1	7,7	358	3,2	3,4	0,799	382	68	
45	M3BP 250SMB 6	3GBP253220---K	991	93,7	93,8	93,1	0,79	87,3	8,0	433	3,1	3,2	1,33	465	68	

Technical data

IE3 cast iron motors 400 V 50 Hz

IP 55 - IC 411 - Insulation class F, temperature rise class B

IE3 efficiency class according to IEC 60034-30-1; 2014

Output kW	Motor type	Product code	Efficiency IEC 60034-30-1: 2014				Current		Torque			Moment of inertia J = 1/4 GD ₂ kgm ₂	Weight kg	Sound pressure Level L _{PA} dB	
			Speed r/min	Full load 100%	>3/4 load 75%	1/2 load 50%	Power factor Cos	I _n A	I _s /I _N	T _N Nm	T _i /T _N				T _b /T _N
750 r/min = 8 poles			400 V 50Hz				BASIC-design								
0.37	M3BP 90SLF 8	3GBP094060---K	710	69,3	67,8	62,5	0,54	1,37	3,3	5,0	2,3	3,3	0,0056	28	50
0.55	M3BP 90LG 8	3GBP094570---K	710	73,0	70,8	64,6	0,53	2,0	4,1	7,7	2,5	3,2	0,0072	32	53
0.75	M3BP 100LKA 8	3GBP104810---K	710	75,0	74,5	70,5	0,65	2,1	4,4	10,0	2,4	2,8	0,00855	37	53
1.5	M3BP 112MC 8	3GBP114330---K	717	79,7	80,1	78,8	0,62	4,1	4,3	19,9	1,8	2,6	0,0194	53	55
2.2	M3BP 132SMA 8	3GBP134210---K	725	81,9	82,3	80,2	0,64	5,8	5,2	28,9	2,0	3,0	0,0291	66	57
3	M3BP 132SMG 8	3GBP134270---K	723	83,5	84,1	82,8	0,66	7,5	4,8	39,6	1,8	2,8	0,0375	76	57
4	M3BP 160MLA 8	3GBP164410---K	734	84,8	85,1	83,2	0,65	10,3	4,5	52,0	1,8	2,3	0,091	130	59
5.5	M3BP 160MLB 8	3GBP164420---K	732	86,2	87,1	86,1	0,69	13,0	5,0	71,7	2,0	2,4	0,091	132	59
7.5	M3BP 160MLC 8	3GBP164430---K	733	87,3	88,2	87,2	0,69	17,6	5,1	97,7	2,0	2,4	0,12	167	59
11	M3BP 180MLA 8	3GBP184410---K	731	88,6	89,2	88,4	0,70	25,3	5,0	144	2,1	2,1	0,2	219	59
15	M3BP 200MLA 8	3GBP204410---K	737	89,6	90,5	90,1	0,74	32,5	5,2	194	2,1	2,4	0,45	290	60
18.5	M3BP 225SMA 8	3GBP224210---K	736	90,1	90,8	90,1	0,74	39,8	5,2	240	2,0	2,3	0,669	350	63
22	M3BP 225SMB 8	3GBP224220---K	736	90,6	91,6	91,5	0,73	47,5	5,3	285	2,3	2,5	0,722	363	63
30	M3BP 250SMA 8	3GBP254210---K	741	91,3	91,7	91,0	0,71	67,0	5,6	386	2,7	2,7	1,4	440	63
37	M3BP 280SMA 8	3GBP284210---K	741	91,8	92,0	91,3	0,79	72,6	7,3	476	1,7	3,0	1,85	605	65
45	M3BP 280SMB 8	3GBP284220---K	741	92,2	92,3	91,7	0,78	89,2	7,6	579	1,8	3,1	2,2	645	65
55	M3BP 315SMA 8	3GBP314210---K	742	92,5	93,1	92,5	0,80	106	7,1	707	1,6	2,7	3,2	830	62
75	M3BP 315SMB 8	3GBP314220---K	741	93,1	93,2	93,1	0,82	146	7,1	966	1,7	2,7	4,1	930	62
90	M3BP 315SMC 8	3GBP314230---K	741	93,4	93,7	93,4	0,82	170	7,4	1159	1,8	2,7	4,9	1000	64
110	M3BP 315MLA 8	3GBP314410---K	740	93,7	94,0	94,1	0,83	211	7,3	1419	1,8	2,7	5,8	1150	72
132	M3BP 355SMA 8	3GBP354210---K	744	94,0	93,9	93,4	0,79	256	7,5	1694	1,5	2,6	7,9	1520	69
160	M3BP 355SMB 8	3GBP354220---K	744	94,3	94,3	93,8	0,79	293	7,6	2053	1,6	2,6	9,7	1680	69
200	M3BP 355SMC 8	3GBP354230---K	742	94,6	95,0	94,8	0,79	385	7,4	2576	1,6	2,6	11,3	1820	69
250	M3BP 355MLB 8	3GBP354420---K	743	94,6	94,7	94,1	0,80	472	7,5	3213	1,6	2,7	13,5	2180	72
315	M3BP 400LA 8	3GBP404510---K	744	94,6	94,5	94,0	0,80	592	7,0	4043	1,2	2,6	17	2900	71
315	M3BP 400LKA 8	3GBP404810---K	744	94,6	94,5	94,0	0,80	592	7,0	4043	1,2	2,6	17	2900	71
315	M3BP 400LKB 8	3GBP404810---K	744	94,6	94,5	94,0	0,80	592	7,0	4043	1,2	2,6	17	2900	71
315	M3BP 355LKB 8	3GBP354820---K	742	94,6	94,8	94,2	0,80	595	7,9	4053	1,7	2,7	16,5	2600	75
355	M3BP 400LB 8	3GBP404520---K	743	94,6	94,9	94,6	0,83	641	6,8	4562	1,2	2,5	21	3200	71
355	M3BP 400LKB 8	3GBP404820---K	743	94,6	94,9	94,6	0,83	641	6,8	4562	1,2	2,5	21	3200	71
400	M3BP 400LC 8	3GBP404530---K	744	94,6	94,9	94,3	0,81	735	6,0	5134	1,3	2,7	24	3400	71
400	M3BP 400LKC 8	3GBP404830---K	744	94,6	94,9	94,3	0,81	735	6,0	5134	1,3	2,7	24	3400	71
450	M3BP 450LA 8	3GBP454510---K	744	94,6	95,0	94,6	0,83	813	6,0	5775	1,0	2,5	26	3750	80
500	M3BP 450LB 8	3GBP454520---K	744	94,6	94,7	94,5	0,83	902	6,4	6417	1,0	2,6	29	4000	80
560	M3BP 450LC 8	3GBP454530---K	744	94,6	94,9	94,2	0,81	1038	7,0	7188	1,2	2,9	35	4350	80
630	M3BP 450LD 8	3GBP454540---K	745	94,6	94,8	94,0	0,82	1162	7,6	8075	1,3	3,2	41	4800	80

Output kW	Motor type	Product code	Efficiency IEC 60034-30-1: 2014				Current		Torque			Moment of inertia J = 1/4 GD ₂ kgm ₂	Weight kg	Sound pressure Level L _{PA} dB	
			Speed r/min	Full load 100%	3/4 load 75%	1/2 load 50%	Power factor Cos	I _n A	I _s /I _N	T _N Nm	T _i /T _N				T _b /T _N
750 r/min = 8 poles			400 V 50Hz				COMPACT-design								
55	M3BP 280SMC 8	3GBP284230---K	740	92,5	92,8	92,3	0,77	107	8,1	708	2,2	3,4	2,85	725	65
75	M3BP 280MLB 8	3GBP284420---K	737	93,1	93,9	94,2	0,79	148	6,7	981	1,9	2,8	4,1	890	72
132	M3BP 315LKA 8	3GBP314810---K	744	94,0	94,3	93,9	0,78	263	7,3	1694	1,6	2,6	6,8	1470	74
150	M3BP 315LKB 8	3GBP314820---K	744	94,2	94,4	94,0	0,77	297	7,7	1924	1,7	2,6	7,7	1560	74
160	M3BP 315LKC 8	3GBP314830---K	744	94,3	94,9	94,8	0,77	315	7,7	2052	1,8	2,7	9,1	1610	74

Technical data

IE2 cast iron motors 400 V 50 Hz

IP 55 - IC 411 - Insulation class F, temperature rise class B

IE2 efficiency class according to IEC 60034-30-1; 2014

Output kW	Motor type	Product code	Efficiency IEC 60034-30-1: 2014				Current		Torque			Moment of inertia J = 1/4 GD ₂ kgm ₂	Weight kg	Sound pressure Level L _{PA} dB	
			Speed r/min	Full load 100%	>3/4 load 75%	1/2 load 50%	Power factor Cos	I _n A	I _s /I _N	T _N Nm	T _i /T _N				T _b /T _N
3000 r/min = 2 poles			400 V 50Hz				BASIC-design								
0.37	M3BP 71MA 2	3GBP071321---B	2785	69,5	70,8	67,8	0,79	0,91	4,6	1,26	2,5	2,8	0,0004	11	57
0.55	M3BP 71MB 2	3GBP071322---B	2790	74,1	75,4	73,4	0,79	1,29	5,1	1,88	3,1	3,1	0,0005	11	57
0.75	M3BP 80MB 2	3GBP081322---B	2895	80,6	79,6	75,6	0,74	1,80	7,7	2,4	4,2	4,2	0,001	16	57
1.1	M3BP 80MC 2	3GBP081323---B	2870	81,8	81,7	78,9	0,80	2,4	7,5	3,6	3,7	4,6	0,0012	18	60
1.5	M3BP 90SLB 2	3GBP091322---B	2900	81,3	81,9	80,3	0,87	3,3	7,5	4,9	2,5	2,6	0,00254	24	69
2.2	M3BP 90SLC 2	3GBP091323---B	2885	83,2	85,5	84,3	0,88	4,2	6,8	7,2	2,4	3,2	0,0028	25	64
3	M3BP 100LB 2	3GBP101322---B	2925	85,2	84,9	82,7	0,87	5,8	9,1	9,7	3,1	3,5	0,00528	36	68
4	M3BP 112MB 2	3GBP111322---B	2895	86,1	87,0	86,6	0,89	7,5	8,1	13,1	2,9	3,2	0,00575	37	70
5.5	M3BP 132SMB 2	3GBP131322---B	2865	87,7	88,4	87,7	0,86	10,0	7,0	18,3	2,6	2,7	0,0128	68	70
7.5	M3BP 132SMC 2	3GBP131324---B	2890	88,2	88,8	87,6	0,89	13,7	7,3	24,9	2,6	3,6	0,0136	70	70
11	M3BP 160MLA 2	3GBP161410---G	2938	90,6	91,5	91,1	0,90	19,2	7,5	35,7	2,4	3,1	0,044	127	69
15	M3BP 160MLB 2	3GBP161420---G	2934	91,5	92,4	92,2	0,90	26,0	7,5	48,8	2,5	3,3	0,053	141	69
18.5	M3BP 160MLC 2	3GBP161430---G	2923	90,9	92,1	92,1	0,92	31,5	7,5	60,2	2,5	2,9	0,063	170	69
22	M3BP 180MLA 2	3GBP181410---G	2947	92,2	92,7	92,2	0,87	39,6	7,7	71,1	2,4	3,2	0,076	190	69
30	M3BP 200MLA 2	3GBP201410---G	2956	93,1	93,5	92,8	0,90	51,6	7,7	96,9	2,7	3,1	0,178	283	72
37	M3BP 200MLB 2	3GBP201420---G	2952	92,5	92,8	91,9	0,90	63,5	8,2	119	2,7	3,2	0,196	298	72
45	M3BP 225SMA 2	3GBP221210---G	2961	93,6	93,9	93,1	0,88	78,8	6,7	145	2,5	2,5	0,244	347	74
55	M3BP 250SMA 2	3GBP251210---G	2967	94,1	94,4	93,8	0,88	95,8	6,8	177	2,2	2,7	0,507	405	75
75	M3BP 280SMA 2	3GBP281210---G	2977	94,3	93,8	92,3	0,88	131	7,6	240	2,1	3,0	0,8	625	77
90	M3BP 280SMB 2	3GBP281220---G	2976	94,6	94,7	93,8	0,89	154	7,4	288	2,1	2,9	0,9	665	77
110	M3BP 315SMA 2	3GBP311210---G	2982	94,9	94,4	92,9	0,86	197	7,4	352	2,2	3,2	1,2	940	78
132	M3BP 315SMB 2	3GBP311220---G	2982	95,1	94,8	93,6	0,88	227	7,4	422	2,2	3,0	1,4	940	78
160	M3BP 315SMC 2	3GBP311230---G	2981	95,4	95,2	94,2	0,89	271	7,5	512	2,3	3,0	1,7	1025	78
200	M3BP 315MLA 2	3GBP311410---G	2980	95,7	95,7	94,9	0,90	335	7,7	640	2,6	3,0	2,1	1190	78
250	M3BP 355SMA 2	3GBP351210---G	2984	95,7	95,5	94,5	0,89	423	7,7	800	2,1	3,3	3	1600	83
315	M3BP 355SMB 2	3GBP351220---G	2980	95,7	95,6	94,9	0,89	531	7,0	1009	2,1	3,0	3,4	1680	83
355	M3BP 355SMC 2	3GBP351230---G	2984	95,7	95,7	94,9	0,88	603	7,2	1136	2,2	3,0	3,6	1750	83
400	M3BP 355MLA 2	3GBP351410---G	2982	95,0	94,7	93,6	0,88	677	7,1	1280	2,3	2,9	4,1	2000	83
450	M3BP 355MLB 2	3GBP351420---G	2983	95,0	95,0	93,9	0,90	743	7,9	1440	2,2	2,9	4,3	2080	83
500	M3BP 355LKA 2	3GBP351810---G	2982	95,0	95,0	94,3	0,90	827	7,5	1601	2,0	3,9	4,8	2320	83
560	M3BP 355LKB 2	3GBP351820---G	2983	95,0	95,0	94,1	0,90	925	8,0	1792	2,2	4,1	5,2	2460	83
560	M3BP 400LA 2	3GBP401510---G	2988	95,0	95,0	93,9	0,89	934	7,8	1789	2,5	3,7	7,9	2950	85
560	M3BP 400LKA 2	3GBP401810---G	2988	95,0	95,0	93,9	0,89	934	7,8	1789	2,5	3,7	7,9	2950	85
630	M3BP 400LB 2	3GBP401520---G	2987	95,0	94,6	93,7	0,89	1049	7,6	2014	2,6	3,7	8,2	3050	85
630	M3BP 400LKB 2	3GBP401820---G	2987	95,0	94,6	93,7	0,89	1049	7,6	2014	2,6	3,7	8,2	3050	85
710	M3BP 400LC 2	3GBP401530---G	2987	95,0	94,8	93,9	0,89	1178	7,2	2270	2,6	3,4	9,3	3300	85
710	M3BP 400LKC 2	3GBP401830---G	2987	95,0	94,8	93,9	0,89	1178	7,2	2270	2,6	3,4	9,3	3300	85
800	M3BP 450LA 2	3GBP451510---G	2990	95,0	94,6	93,4	0,87	1362	7,8	2555	1,3	3,4	12,2	4000	87
900	M3BP 450LB 2	3GBP451520---G	2990	95,0	94,6	93,6	0,87	1534	7,6	2874	1,5	3,1	13,5	4200	87

Output kW	Motor type	Product code	Efficiency IEC 60034-30-1: 2014				Current		Torque			Moment of inertia J = 1/4 GD ₂ kgm ₂	Weight kg	Sound pressure Level L _{PA} dB	
			Speed r/min	Full load 100%	3/4 load 75%	1/2 load 50%	Power factor Cos	I _n A	I _s /I _N	T _N Nm	T _i /T _N				T _b /T _N
3000 r/min = 2 poles			400 V 50Hz				COMPACT-design								
22	M3BP 160MLD 2	3GBP161440-...G	2933	91,7	92,8	92,8	0,90	38,0	8,1	71,6	3,2	3,6	0,063	170	69
27	M3BP 160MLE 2	3GBP161450-...G	2939	92,2	93,1	93,0	0,90	46,4	8,8	87,7	3,4	3,8	0,072	184	69
30	M3BP 180MLB 2	3GBP181420-...G	2950	92,7	93,5	93,3	0,88	53,0	7,9	97,1	2,8	3,3	0,092	208	69
45	M3BP 200MLC 2	3GBP201430-...G	2957	93,3	93,8	93,2	0,88	79,1	7,9	145	3,1	3,3	0,196	298	72
55	M3BP 200MLD 2	3GBP201440-...G	2953	93,8	94,4	94,3	0,89	95,0	7,8	177	2,9	3,3	0,217	314	72
55	M3BP 225SMB 2	3GBP221220-...G	2961	93,9	94,3	93,6	0,88	96,0	6,5	177	2,4	2,5	0,274	369	74
75	M3BP 225SMC 2	3GBP221230-...G	2969	94,4	94,6	94,0	0,84	136	7,4	241	3,2	3,1	0,309	396	74
75	M3BP 250SMB 2	3GBP251220-...G	2970	94,5	94,8	94,4	0,89	128	7,6	241	2,8	3,1	0,583	451	75
80	M3BP 225SMD 2	3GBP221240-...G	2964	94,4	94,8	94,3	0,87	140	7,3	257	3,0	2,8	0,329	410	74
90	M3BP 250SMC 2	3GBP251230-...G	2971	94,9	95,2	94,8	0,89	153	7,6	289	2,5	3,1	0,644	487	75
110	M3BP 280SML 2	3GBP281230-...G	2978	95,1	95,1	94,5	0,90	186	7,9	352	2,4	3,0	1,15	725	77
132	M3BP 280MLA 2	3GBP281410-...G	2977	95,3	95,3	94,8	0,90	221	7,5	423	2,5	3,0	1,4	840	81
160	M3BP 280MLB 2	3GBP281420-...G	2976	95,5	95,7	95,3	0,91	265	7,6	513	2,8	3,0	1,55	890	81
250	M3BP 315LKA 2	3GBP311810-...G	2980	95,7	95,7	95,2	0,89	423	7,6	801	2,8	2,9	2,65	1440	78
315	M3BP 315LKC 2	3GBP311830-...G	2981	95,7	95,7	95,4	0,89	533	8,8	1009	3,2	3,2	3,3	1630	78

Technical data

IE2 cast iron motors 400 V 50 Hz

IP 55 - IC 411 - Insulation class F, temperature rise class B

IE2 efficiency class according to IEC 60034-30-1; 2014

Output kW	Motor type	Product code	Efficiency IEC 60034-30-1: 2014					Current		Torque			Moment of inertia J = 1/4 GD ₂ kgm ₂	Weight kg	Sound pressure Level L _{PA} dB	
			Speed r/min	Full load 100%	>3/4 load 75%	1/2 load 50%	Power factor Cos	I _n A	I _s /I _N	T _N Nm	T _i /T _N	T _b /T _N				
1500 r/min = 4 poles			400 V 50Hz					BASIC-design								
0.25	M3BP 71MA 4	3GBP072321---B	1430	68,5	66,8	59,9	0,67	0,76	4,7	1,67	2,2	3,0	0,0006	10	45	
0.37	M3BP 71MB 4	3GBP072322---B	1411	72,7	73,3	69,9	0,74	0,96	5,2	2,5	2,6	2,9	0,001	12	45	
0.55	M3BP 80MA 4	3GBP082321---B	1406	77,1	78,6	76,8	0,78	1,29	5,4	3,7	2,8	2,9	0,0022	18	50	
0.75	M3BP 80MD 4	3GBP082324---B	1430	81,0	81,0	78,2	0,73	1,82	6,3	5,0	3,3	3,6	0,002	17	50	
1.1	M3BP 90SLB 4	3GBP092322---B	1435	81,4	82,0	80,1	0,80	2,4	6,5	7,3	2,4	3,4	0,0044	25	50	
1.5	M3BP 90SLD 4	3GBP092325---B	1430	84,3	85,1	83,9	0,83	3,0	6,3	10,0	2,7	3,4	0,0053	27	56	
2.2	M3BP 100LC 4	3GBP102323---B	1450	85,9	85,1	83,4	0,78	4,6	7,7	14,5	3,2	4,1	0,0095	36	56	
3	M3BP 100LD 4	3GBP102324---B	1450	86,8	86,9	85,3	0,79	6,1	7,7	19,8	2,9	3,6	0,011	38	58	
4	M3BP 112MB 4	3GBP112322---B	1440	86,6	87,2	86,8	0,82	7,9	7,0	26,5	2,5	2,9	0,0125	44	59	
5.5	M3BP 132SMB 4	3GBP132322---B	1460	89,0	89,8	88,9	0,80	10,8	7,1	36,0	2,2	3,2	0,0328	70	67	
7.5	M3BP 132SMC 4	3GBP132323---B	1450	89,3	90,1	90,0	0,81	14,5	7,2	49,4	2,5	3,5	0,0366	73	64	
11	M3BP 160MLA 4	3GBP162410---G	1466	89,8	91,1	90,8	0,84	20,9	6,8	71,6	2,2	2,8	0,081	135	62	
15	M3BP 160MLB 4	3GBP162420---G	1470	91,4	92,3	92,2	0,83	28,5	7,1	97,4	2,6	3,0	0,099	165	62	
18.5	M3BP 180MLA 4	3GBP182410---G	1477	91,9	92,8	92,6	0,84	34,5	7,2	119	2,6	2,9	0,166	205	62	
22	M3BP 180MLB 4	3GBP182420---G	1475	92,3	93,3	93,2	0,84	40,9	7,3	142	2,6	3,0	0,195	222	62	
30	M3BP 200MLA 4	3GBP202410---G	1480	93,2	94,0	93,7	0,84	55,3	7,4	193	2,8	3,0	0,309	291	63	
37	M3BP 225SMA 4	3GBP222210---G	1474	93,4	93,9	93,4	0,84	68,0	7,1	238	2,6	2,7	0,356	324	66	
45	M3BP 225SMB 4	3GBP222220---G	1480	93,9	94,3	93,9	0,85	81,3	7,5	290	2,8	3,2	0,44	356	66	
55	M3BP 250SMA 4	3GBP252210---G	1471	93,5	94,2	93,8	0,85	98,9	7,0	354	2,0	3,1	0,765	414	67	
75	M3BP 280SMA 4	3GBP282210---G	1484	94,5	94,7	94,4	0,85	134	6,9	482	2,5	2,8	1,25	625	68	
90	M3BP 280SMB 4	3GBP282220---G	1483	94,7	95,0	94,5	0,85	160	7,2	579	2,5	2,7	1,5	665	68	
110	M3BP 315SMA 4	3GBP312210---G	1487	94,5	94,5	93,6	0,86	194	7,2	706	2,3	2,8	2,3	900	70	
132	M3BP 315SMB 4	3GBP312220---G	1487	95,4	95,4	94,7	0,86	232	7,1	847	2,3	2,7	2,6	960	70	
160	M3BP 315SMC 4	3GBP312230---G	1487	95,3	95,3	94,8	0,85	284	7,2	1027	2,4	2,9	2,9	1000	70	
200	M3BP 315MLA 4	3GBP312410---G	1486	95,6	95,6	95,3	0,86	351	7,2	1285	2,5	2,9	3,5	1160	74	
250	M3BP 355SMA 4	3GBP352210---G	1488	95,9	96,0	95,5	0,85	442	7,1	1604	2,3	2,7	5,9	1610	75	
315	M3BP 355SMB 4	3GBP352220---G	1488	95,9	96,2	95,8	0,86	550	7,3	2021	2,3	2,8	6,9	1780	75	
355	M3BP 355SMC 4	3GBP352230---G	1487	95,9	96,2	95,9	0,87	614	6,8	2279	2,4	2,7	7,2	1820	78	
400	M3BP 355MLA 4	3GBP352410---G	1489	95,1	95,1	94,5	0,85	705	6,8	2565	2,3	2,6	8,4	2140	78	
450	M3BP 355MLB 4	3GBP352420---G	1490	95,1	95,2	94,6	0,86	780	6,9	2884	2,3	2,9	8,4	2140	78	
500	M3BP 355LKA 4	3GBP352810---G	1490	95,1	95,1	94,2	0,86	865	6,8	3204	2,0	3,0	10	2500	78	
560	M3BP 355LKB 4	3GBP352820---G	1490	95,1	95,1	94,4	0,85	981	7,2	3588	2,6	2,7	10,6	2600	78	
560	M3BP 400LA 4	3GBP402510---G	1491	95,1	95,1	94,3	0,85	982	7,4	3586	2,4	2,8	15	3200	80	
560	M3BP 400LKA 4	3GBP402810---G	1491	95,1	95,1	94,3	0,85	982	7,4	3586	2,4	2,8	15	3200	80	
630	M3BP 400LB 4	3GBP402520---G	1491	95,1	95,1	94,3	0,87	1077	7,6	4034	2,2	2,9	16	3300	80	
630	M3BP 400LKB 4	3GBP402820---G	1491	95,1	95,1	94,3	0,87	1077	7,6	4034	2,2	2,9	16	3300	80	
710	M3BP 400LC 4	3GBP402530---G	1491	95,1	95,1	94,4	0,86	1227	7,6	4547	2,4	3,0	17	3400	80	
710	M3BP 400LKC 4	3GBP402830---G	1491	95,1	95,1	94,4	0,86	1227	7,6	4547	2,4	3,0	17	3400	80	
800	M3BP 450LA 4	3GBP452510---G	1491	95,1	95,1	94,3	0,86	1396	7,0	5121	1,3	2,8	23	4050	87	
900	M3BP 450LB 4	3GBP452520---G	1492	95,1	94,9	94,1	0,86	1573	7,0	5761	1,3	2,8	25	4350	87	
1000	M3BP 450LC 4	3GBP452530---G	1491	95,1	95,1	94,2	0,86	1724	6,8	6404	1,3	2,7	30	4700	87	

Output kW	Motor type	Product code	Efficiency IEC 60034-30-1: 2014					Current		Torque			Moment of inertia J = 1/4 GD ₂ kgm ₂	Weight kg	Sound pressure Level L _{PA} dB
			Speed r/min	Full	3/4	1/2	Power factor Cos	I _n A	I _s /I _N	T _N Nm	T _v /T _N	T _b /T _N			
				load 100%	load 75%	load 50%									
1500 r/min = 4 poles			400 V 50Hz					COMPACT-design							
18.5	M3BP 160MLC 4	3GBP162430-**-G	1469	91,4	91,9	91,7	0,84	34,7	7,6	120	3,0	3,2	0,11	173	62
22	M3BP 160MLD 4	3GBP162440-**-G	1466	91,6	92,4	92,5	0,86	40,8	6,9	143	2,5	2,9	0,125	187	62
30	M3BP 180MLC 4	3GBP182430-**-G	1474	92,3	92,8	92,7	0,83	56,5	7,3	194	2,7	2,9	0,217	235	62
37	M3BP 200MLB 4	3GBP202420-**-G	1479	93,4	94,4	94,4	0,85	67,2	7,1	238	2,6	2,9	0,343	307	63
45	M3BP 200MLC 4	3GBP202430-**-G	1479	93,6	94,4	94,2	0,83	83,6	7,5	290	2,9	3,2	0,366	319	63
55	M3BP 225SMC 4	3GBP222230-**-G	1478	94,0	94,6	94,4	0,85	99,3	7,4	355	2,9	3,1	0,474	370	66
64	M3BP 225SMD 4	3GBP222240-**-G	1480	94,2	94,6	94,1	0,85	115	8,0	412	3,3	3,3	0,542	399	66
75	M3BP 250SMB 4	3GBP252220-**-G	1478	94,4	95,1	94,8	0,85	134	7,3	484	2,8	3,1	0,866	450	67
90	M3BP 250SMC 4	3GBP252230-**-G	1478	94,6	95,3	95,0	0,84	163	7,4	581	3,1	3,3	0,941	478	67
110	M3BP 280SMC 4	3GBP282230-**-G	1485	95,1	95,4	95,1	0,86	193	7,6	707	3,0	3,0	1,85	725	68
132	M3BP 280MLA 4	3GBP282410-**-G	1483	95,3	95,5	95,1	0,86	232	7,0	849	2,7	2,8	2,3	840	75
160	M3BP 280MLB 4	3GBP282420-**-G	1484	95,6	95,9	95,7	0,85	284	7,4	1029	2,9	2,9	2,5	890	75
250	M3BP 315LKA 4	3GBP312810-**-G	1487	95,7	95,8	95,2	0,85	443	7,4	1605	2,5	2,9	4,4	1410	78
280	M3BP 315LKB 4	3GBP312820-**-G	1487	95,8	95,9	95,4	0,87	491	7,6	1798	2,6	3,0	5	1520	78
315	M3BP 315LKC 4	3GBP312830-**-G	1488	95,8	95,9	95,3	0,86	559	7,8	2021	2,6	3,2	5,5	1600	78

Technical data

IE2 cast iron motors 400 V 50 Hz

IP 55 - IC 411 - Insulation class F, temperature rise class B

IE2 efficiency class according to IEC 60034-30-1; 2014

Output kW	Motor type	Product code	Efficiency IEC 60034-30-1: 2014				Current		Torque			Moment of inertia J = 1/4 GD ₂ kgm ₂	Weight kg	Sound pressure Level L _{PA} dB	
			Speed r/min	Full load 100%	>3/4 load 75%	1/2 load 50%	Power factor Cos	I _n A	I _s /I _N	T _N Nm	T _i /T _N				T _b /T _N
1000 r/min = 6 poles			400 V 50Hz				BASIC-design								
0.18	M3BP 71MA 6	3GBP073321---B	900	56,6	56,0	49,8	0,73	0,58	3,1	1,91	1,9	2,0	0,0009	10	42
0.25	M3BP 71MB 6	3GBP073322---B	910	61,6	61,0	55,3	0,67	0,85	3,3	2,6	2,4	2,6	0,0011	12	42
0.37	M3BP 80MA 6	3GBP083321---B	923	67,6	67,5	62,6	0,73	1,04	4,4	3,8	2,6	2,8	0,0019	15	47
0.55	M3BP 80MB 6	3GBP083322---B	905	73,1	75,9	75,1	0,76	1,42	4,4	5,8	2,7	2,6	0,0034	20	47
0.75	M3BP 90SLC 6	3GBP093323---B	960	76,3	74,7	69,5	0,58	2,3	4,5	7,4	3,2	3,9	0,00491	25	44
1.1	M3BP 90SLE 6	3GBP093324---B	930	78,2	78,7	76,5	0,72	2,8	4,0	11,2	2,0	2,3	0,0054	28	44
1.5	M3BP 100L 6	3GBP103322---B	950	81,3	82,1	80,7	0,69	3,7	5,2	15,0	2,2	3,4	0,00873	37	49
2.2	M3BP 112MB 6	3GBP113322---B	950	82,5	83,7	81,6	0,69	5,5	4,4	22,1	2,5	3,1	0,0125	44	66
3	M3BP 132SMB 6	3GBP133321---B	975	85,3	84,2	81,2	0,63	8,0	6,8	29,4	3,0	3,9	0,0334	69	57
4	M3BP 132SMC 6	3GBP133322---B	960	84,9	85,4	83,9	0,68	10,0	5,0	39,7	2,0	2,6	0,0334	69	57
5.5	M3BP 132SMF 6	3GBP133324---B	965	86,1	86,6	85,5	0,71	12,9	6,4	54,4	2,0	2,3	0,0487	86	57
7.5	M3BP 160MLA 6	3GBP163410---G	975	88,5	89,9	89,7	0,79	15,4	7,4	73,4	1,7	3,2	0,087	134	59
11	M3BP 160MLB 6	3GBP163420---G	972	89,3	90,6	90,5	0,79	22,5	7,5	108	1,9	2,9	0,114	172	59
15	M3BP 180MLA 6	3GBP183410---G	977	90,2	90,6	90,0	0,76	31,5	5,8	146	1,8	2,7	0,168	207	59
18.5	M3BP 200MLA 6	3GBP203410---G	988	91,6	92,2	91,7	0,80	36,4	6,7	178	2,3	2,9	0,382	269	63
22	M3BP 200MLB 6	3GBP203420---G	983	90,9	92,0	91,8	0,82	42,0	6,6	212	2,1	2,7	0,448	291	63
30	M3BP 225SMA 6	3GBP223210---G	986	92,6	93,3	92,8	0,83	56,2	7,0	290	2,6	2,9	0,663	349	63
37	M3BP 250SMA 6	3GBP253210---G	984	92,2	92,9	92,5	0,82	69,9	6,8	357	2,0	2,7	1,13	395	63
45	M3BP 280SMA 6	3GBP283210---G	990	93,4	93,8	93,5	0,83	83,8	7,0	434	2,5	2,5	1,85	605	66
55	M3BP 280SMB 6	3GBP283220---G	990	93,1	93,6	93,3	0,84	100	7,0	530	2,7	2,6	2,2	645	66
75	M3BP 315SMA 6	3GBP313210---G	992	94,4	94,4	93,5	0,82	139	7,4	721	2,4	2,8	3,2	830	70
90	M3BP 315SMB 6	3GBP313220---G	992	94,8	94,7	94,1	0,84	166	7,5	866	2,4	2,8	4,1	930	70
110	M3BP 315SMC 6	3GBP313230---G	991	95,0	95,0	94,6	0,83	201	7,4	1059	2,5	2,9	4,9	1000	70
132	M3BP 315MLA 6	3GBP313410---G	991	95,3	95,4	94,9	0,83	240	7,5	1271	2,7	3,0	5,8	1150	68
160	M3BP 355SMA 6	3GBP353210---G	993	95,4	95,6	95,2	0,83	291	7,0	1538	2,0	2,6	7,9	1520	75
200	M3BP 355SMB 6	3GBP353220---G	993	95,7	95,9	95,7	0,83	364	7,2	1923	2,6	2,7	9,7	1680	75
250	M3BP 355SMC 6	3GBP353230---G	993	95,7	95,8	95,4	0,82	460	7,4	2404	2,6	2,9	11,3	1820	75
315	M3BP 355MLB 6	3GBP353420---G	992	95,7	96,0	95,5	0,83	570	7,0	3032	2,5	2,7	13,5	2180	78
355	M3BP 355LKA 6	3GBP353810---G	992	95,7	95,9	95,4	0,81	658	7,6	3417	2,7	2,9	15,5	2500	78
400	M3BP 400LA 6	3GBP403510---G	993	95,0	95,0	94,2	0,82	731	7,1	3846	2,3	2,7	17	2900	76
400	M3BP 400LKA 6	3GBP403810---G	993	95,0	95,0	94,2	0,82	731	7,1	3846	2,3	2,7	17	2900	76
400	M3BP 355LKB 6	3GBP353820---G	992	95,0	95,0	94,3	0,83	724	7,2	3850	2,6	2,6	16,5	2600	78
450	M3BP 400LB 6	3GBP403520---G	994	95,0	95,0	94,3	0,82	819	7,4	4323	2,4	2,7	20,5	3150	76
450	M3BP 400LKB 6	3GBP403820---G	994	95,0	95,0	94,3	0,82	819	7,4	4323	2,4	2,7	20,5	3150	76
500	M3BP 400LC 6	3GBP403530---G	993	95,0	94,8	94,3	0,83	891	7,2	4809	2,5	2,7	22	3300	76
500	M3BP 400LKC 6	3GBP403830---G	993	95,0	94,8	94,3	0,83	891	7,2	4809	2,5	2,7	22	3300	76
500	M3BP 400LKC 6	3GBP403830---G	993	95,0	94,8	94,3	0,83	891	7,2	4809	2,5	2,7	22	3300	76
560	M3BP 400LD 6	3GBP403540---G	993	95,0	95,0	94,2	0,85	984	7,4	5386	2,4	2,8	24	3400	77
560	M3BP 400LKD 6	3GBP403840---G	993	95,0	95,0	94,2	0,85	984	7,4	5386	2,4	2,8	24	3400	77
630	M3BP 450LA 6	3GBP453510---G	994	95,0	95,1	94,4	0,84	1127	6,5	6053	1,1	2,5	31	4150	85
710	M3BP 450LB 6	3GBP453520---G	995	95,0	95,1	94,3	0,85	1244	7,0	6814	1,3	2,5	37	4500	85
800	M3BP 450LC 6	3GBP453530---G	995	95,0	95,0	94,1	0,84	1415	7,2	7677	1,3	2,7	41	4800	85

Output kW	Motor type	Product code	Efficiency IEC 60034-30-1: 2014					Current		Torque			Moment of inertia J = 1/4 GD ₂ kgm ₂	Weight kg	Sound pressure Level L _{PA} dB
			Speed r/min	Full load 100%	3/4 load 75%	1/2 load 50%	Power factor Cos	I _n A	I _s /I _N	T _N Nm	T _v /T _N	T _b /T _N			
1000 r/min = 6 poles			400 V 50Hz					COMPACT-design							
15	M3BP 160MLC 6	3GBP163430-...G	971	89,7	90,5	90,2	0,77	31,3	7,3	147	1,8	3,6	0,131	185	59
18.5	M3BP 180MLB 6	3GBP183420-...G	975	90,7	92,0	92,0	0,79	37,2	5,8	181	1,7	2,7	0,198	221	59
30	M3BP 200MLC 6	3GBP203430-...G	985	92,0	93,1	92,8	0,83	56,7	6,9	290	2,3	2,8	0,531	318	63
37	M3BP 225SMB 6	3GBP223220-...G	985	92,2	93,1	93,1	0,83	69,1	6,6	358	2,3	2,6	0,821	393	63
45	M3BP 225SMC 6	3GBP223230-...G	984	92,7	93,3	93,3	0,83	84,4	6,4	436	2,3	2,6	0,821	393	63
45	M3BP 250SMB 6	3GBP253220-...G	989	93,4	94,1	93,9	0,83	83,7	7,0	434	2,5	2,7	1,37	441	63
55	M3BP 250SMC 6	3GBP253230-...G	988	93,2	93,7	93,6	0,84	101	7,1	531	2,6	2,8	1,5	468	63
75	M3BP 280SMC 6	3GBP283230-...G	990	94,1	94,7	94,5	0,84	137	7,3	723	2,8	2,7	2,85	725	66
90	M3BP 280MLA 6	3GBP283410-...G	990	94,1	94,3	93,7	0,81	170	7,1	868	2,4	2,5	3,1	840	70
110	M3BP 280MLB 6	3GBP283420-...G	990	94,5	94,8	94,4	0,82	205	7,5	1061	2,7	2,6	4,1	890	70
160	M3BP 315LKA 6	3GBP313810-...G	992	95,3	95,3	94,7	0,83	291	7,5	1540	2,6	2,8	7,3	1410	74
180	M3BP 315LKB 6	3GBP313820-...G	992	95,3	95,4	94,8	0,83	328	7,4	1732	2,6	2,8	8,3	1520	74
200	M3BP 315LKC 6	3GBP313830-...G	989	95,4	95,6	95,3	0,85	360	6,8	1931	2,5	2,6	9,2	1600	74

Technical data

IE2 cast iron motors 400 V 50 Hz

IP 55 - IC 411 - Insulation class F, temperature rise class B

IE2 efficiency class according to IEC 60034-30-1; 2014

Output kW	Motor type	Product code	Efficiency IEC 60034-30-1: 2014				Current		Torque			Moment of inertia J = 1/4 GD ₂ kgm ₂	Weight kg	Sound pressure Level L _{PA} dB	
			Speed r/min	Full load 100%	>3/4 load 75%	1/2 load 50%	Power factor Cos	I _n A	I _s /I _N	T _N Nm	T _l /T _N				T _b /T _N
750 r/min = 8 poles			400 V 50Hz				BASIC-design								
0.12	M3BP 71MB 8	3GBP074102---B	685	39,8	34,2	23,9	0,58	0,60	2,7	1,67	2,2	2,4	0,0011	12	43
0.18	M3BP 80MA 8	3GBP084101---B	680	45,9	45,4	38,6	0,61	0,70	3,0	2,5	2,0	2,4	0,0019	15	45
0.25	M3BP 80MB 8	3GBP084102---B	680	50,6	51,0	46,0	0,62	0,94	3,3	3,5	2,0	2,2	0,0024	17	50
0.37	M3BP 90SLB 8	3GBP094102---B	705	56,1	54,5	47,1	0,57	1,47	2,8	5,0	1,8	2,2	0,0044	24	50
0.55	M3BP 90SLC 8	3GBP094103---B	673	61,7	63,6	59,8	0,61	2,1	2,6	7,8	1,5	1,8	0,0049	25	53
0.75	M3BP 100LA 8	3GBP104101---B	710	74,0	72,3	67,1	0,61	2,5	3,7	10,1	1,8	2,6	0,0072	30	46
1.1	M3BP 100LB 8	3GBP104102---B	695	76,0	76,4	74,5	0,66	3,1	3,6	15,1	1,6	2,3	0,00871	30	53
1.5	M3BP 112M 8	3GBP114101---B	690	74,4	75,9	74,1	0,74	4,1	3,5	20,9	1,9	2,6	0,0106	39	55
2.2	M3BP 132SMA 8	3GBP134101---B	715	78,3	75,1	75,5	0,66	6,5	4,7	29,2	1,6	2,8	0,0334	70	56
4	M3BP 160MLA 8	3GBP164410---G	728	84,0	85,1	83,6	0,67	10,2	5,4	52,4	1,5	2,6	0,068	120	59
5.5	M3BP 160MLB 8	3GBP164420---G	726	84,6	85,9	84,8	0,67	13,9	5,6	72,3	1,4	2,6	0,085	134	59
7.5	M3BP 160MLC 8	3GBP164430---G	727	86,0	87,3	86,5	0,65	19,3	4,7	98,5	1,5	2,8	0,132	184	59
11	M3BP 180MLA 8	3GBP184410---G	731	86,9	87,6	86,7	0,67	27,3	4,4	143	1,8	2,6	0,214	233	59
15	M3BP 200MLA 8	3GBP204410---G	737	89,5	90,8	90,3	0,74	32,4	5,3	194	2,0	2,4	0,45	290	60
18.5	M3BP 225SMA 8	3GBP224210---G	739	90,0	91,1	90,6	0,73	40,1	5,2	239	2,0	2,3	0,669	350	63
22	M3BP 225SMB 8	3GBP224220---G	738	90,5	91,4	91,0	0,74	46,8	5,5	284	2,0	2,3	0,722	363	63
30	M3BP 250SMA 8	3GBP254210---G	742	91,2	91,8	91,1	0,71	66,0	5,8	386	2,6	2,4	1,4	440	63
37	M3BP 280SMA 8	3GBP284210---G	741	91,7	92,0	91,2	0,79	72,6	7,3	476	1,7	3,0	1,85	605	65
45	M3BP 280SMB 8	3GBP284220---G	741	92,1	92,3	91,7	0,78	89,2	7,6	579	1,8	3,1	2,2	645	65
55	M3BP 315SMA 8	3GBP314210---G	742	92,4	93,0	92,4	0,79	106	7,1	707	1,6	2,7	3,2	830	62
75	M3BP 315SMB 8	3GBP314220---G	741	93,0	93,1	93,0	0,82	146	7,1	966	1,7	2,7	4,1	930	62
90	M3BP 315SMC 8	3GBP314230---G	741	93,3	93,7	93,3	0,82	170	7,4	1159	1,8	2,7	4,9	1000	64
110	M3BP 315MLA 8	3GBP314410---G	740	93,6	93,9	94,0	0,83	211	7,3	1419	1,8	2,7	5,8	1150	72
132	M3BP 355SMA 8	3GBP354210---G	744	93,9	93,8	93,3	0,80	256	7,5	1694	1,5	2,6	7,9	1520	69
160	M3BP 355SMB 8	3GBP354220---G	744	94,2	94,2	93,7	0,77	293	7,6	2053	1,6	2,6	9,7	1680	69
200	M3BP 355SMC 8	3GBP354230---G	742	94,5	95,0	94,8	0,79	385	7,4	2576	1,6	2,6	11,3	1820	69
250	M3BP 355MLB 8	3GBP354420---G	743	94,5	94,7	94,1	0,80	472	7,5	3213	1,6	2,7	13,5	2180	72
315	M3BP 400LA 8	3GBP404510---G	744	93,5	93,3	92,7	0,81	592	7,0	4043	1,2	2,6	17	2900	71
315	M3BP 400LKA 8	3GBP404810---G	744	93,5	93,3	92,7	0,81	592	7,0	4043	1,2	2,6	17	2900	71
315	M3BP 355LKB 8	3GBP354820---G	742	93,5	93,8	93,0	0,80	595	7,9	4053	1,7	2,7	16,5	2600	75
355	M3BP 400LB 8	3GBP404520---G	743	93,5	93,8	93,5	0,83	641	6,8	4562	1,2	2,5	21	3200	71
355	M3BP 400LKB 8	3GBP404820---G	743	93,5	93,8	93,5	0,83	641	6,8	4562	1,2	2,5	21	3200	71
400	M3BP 400LC 8	3GBP404530---G	744	93,5	93,8	93,1	0,82	735	6,0	5134	1,3	2,7	24	3400	71
400	M3BP 400LKC 8	3GBP404830---G	744	93,5	93,8	93,1	0,82	735	6,0	5134	1,3	2,7	24	3400	71
450	M3BP 450LA 8	3GBP454510---G	744	93,5	94,0	93,5	0,83	813	6,0	5775	1,0	2,5	26	3750	80
500	M3BP 450LB 8	3GBP454520---G	744	93,5	93,6	93,3	0,83	902	6,4	6417	1,0	2,6	29	4000	80
560	M3BP 450LC 8	3GBP454530---G	744	93,5	93,8	93,0	0,82	1038	7,0	7188	1,2	2,9	35	4350	80
630	M3BP 450LD 8	3GBP454540---G	745	93,5	93,6	92,7	0,81	1162	7,6	8075	1,3	3,2	41	4800	80

Output kW	Motor type	Product code	Efficiency IEC 60034-30-1: 2014				Current		Torque			Moment of inertia J = 1/4 GD ₂ kgm ₂	Weight kg	Sound pressure Level L _{PA} dB	
			Speed r/min	Full load 100%	3/4 load 75%	1/2 load 50%	Power factor Cos	I _n A	I _s /I _N	T _N Nm	T _i /T _N				T _b /T _N
750 r/min = 8 poles			400 V 50Hz				COMPACT-design								
18.5	M3BP 200MLB 8	3GBP204420-**-G	739	90,0	90,8	90,2	0,74	40,0	5,4	239	2,1	2,3	0,53	318	60
30	M3BP 225SMC 8	3GBP224230-**-G	737	91,2	92,3	92,1	0,73	64,7	5,6	388	2,3	2,4	0,828	393	63
37	M3BP 250SMB 8	3GBP254220-**-G	740	91,7	92,8	92,5	0,73	78,9	5,4	477	2,6	2,3	1,51	468	63
45	M3BP 250SMC 8	3GBP254230-**-G	738	92,1	93,3	93,3	0,74	95,1	5,6	582	2,3	2,4	1,51	468	63
55	M3BP 280SMC 8	3GBP284230-**-G	741	92,4	92,8	92,7	0,80	107	7,9	708	1,9	3,1	2,85	725	65
75	M3BP 280MLB 8	3GBP284420-**-G	739	91,6	91,8	91,0	0,80	144	6,7	969	1,7	2,6	4,1	890	72
132	M3BP 315LKA 8	3GBP314810-**-G	740	92,6	92,9	92,7	0,83	243	7,3	1703	1,8	2,6	7,3	1410	74
150	M3BP 315LKB 8	3GBP314820-**-G	741	94,1	94,7	94,6	0,83	278	7,7	1938	1,9	2,7	8,3	1520	74
160	M3BP 315LKC 8	3GBP314830-**-G	739	94,2	94,7	94,7	0,83	297	7,7	2068	1,9	2,8	9,2	1600	74

Technical data

IE5 cast iron motors 460 V 60 Hz

IP 55 - IC 411 - Insulation class F, temperature rise class B

IE5 efficiency class according to IEC 60034-30-1; 2014

Output kW	Motor type	Product code	Efficiency IEC 60034-30-1: 2014				Current		Torque			Moment of inertia J = 1/4 GD ₂ kgm ₂	Weight kg	Sound pressure Level L _{PA} dB	
			Speed r/min	Full load 100%	3/4 load 75%	1/2 load 50%	Power factor Cos	I _n A	I _s /I _N	T _N Nm	T _i /T _N				T _b /T _N
3600 r/min = 2 poles			460 V 60Hz				BASIC-design								
75	M3BP 280SMB 2	3GBP281220---R	3585	96,0	95,5	94,2	0,9	111	10,3	200	2,7	3,9	0,82	725	77
75	M3BP 280SMB 2	3GBP281220---R	3586	96,0	95,5	94,1	0,9	112	10,3	200	2,9	4,3	0,82	725	77
90	M3BP 280SMC 2	3GBP281230---R	3583	96,3	96,0	95,2	0,9	134	9,0	240	2,4	3,6	0,816	725	77
90	M3BP 280SMC 2	3GBP281230---R	3581	96,3	96,1	95,3	0,9	133	8,4	240	2,2	3,2	0,816	725	77
110	M3BP 315SMB 2	3GBP311220---R	3585	96,3	96,1	95,1	0,9	164	8,2	293	1,7	3,2	1,22	940	81
132	M3BP 315SMC 2	3GBP311230---R	3584	96,6	96,5	95,8	0,9	191	8,3	352	1,9	3,0	1,44	1025	81
160	M3BP 315MLA 2	3GBP311410---R	3585	96,6	96,5	95,9	0,9	231	9,1	426	2,2	3,1	1,7	1190	81
200	M3BP 315MLB 2	3GBP311420---R	3585	96,9	96,8	96,3	0,9	287	8,7	533	2,6	3,3	1,89	1250	81
200	M3BP 355SMA 2	3GBP351210---R	3588	96,9	96,5	95,5	0,9	294	9,6	532	2,0	4,1	2,73	1600	84
250	M3BP 355SMB 2	3GBP351220---R	3585	96,9	96,7	95,9	0,9	363	9,3	666	2,2	3,7	3,1	1680	84
315	M3BP 355SMC 2	3GBP351230---R	3587	96,9	96,7	96,1	0,9	466	8,3	839	2,5	3,4	3,36	1750	84
355	M3BP 355MLA 2	3GBP351410---R	3586	96,9	96,8	96,3	0,9	519	9,2	945	2,6	3,3	3,74	2000	84
400	M3BP 355MLB 2	3GBP351420---R	3588	96,9	96,6	95,7	0,9	585	9,8	1065	2,8	4,4	3,67	2000	89
450	M3BP 355MLC 2	3GBP351430---R	3586	96,9	96,7	96,0	0,9	646	9,6	1198	2,7	4,0	3,91	2080	89
500	M3BP 355LKA 2	3GBP351810---R	3583	96,9	96,8	96,2	0,9	727	9,1	1333	2,5	3,5	4,44	2340	89
560	M3BP 400LA 2	3GBP401510---R	3590	96,9	96,5	95,5	0,9	822	8,7	1490	2,5	3,9	7,27	2950	86
560	M3BP 400LKA 2	3GBP401810---R	3590	96,9	96,5	95,5	0,9	822	8,7	1490	2,5	3,9	7,27	2950	86
630	M3BP 400LB 2	3GBP401520---R	3589	96,9	96,6	95,8	0,9	919	9,0	1676	2,5	3,7	7,81	2950	86
630	M3BP 400LKB 2	3GBP401820---R	3589	96,9	96,6	95,8	0,9	919	9,0	1676	2,5	3,7	7,81	2950	86
710	M3BP 400LC 2	3GBP401530---R	3589	96,9	96,7	95,9	0,9	1033	8,3	1889	2,9	3,5	8,9	3050	86
710	M3BP 400LKC 2	3GBP401830---R	3589	96,9	96,7	95,9	0,9	1033	8,3	1889	2,9	3,5	8,9	3050	86
800	M3BP 450LA 2	3GBP451510---R	3591	96,9	96,5	95,4	0,9	1183	8,1	2127	1,5	3,5	12	4000	90
900	M3BP 450LB 2	3GBP451520---R	3591	96,9	96,5	95,6	0,9	1327	8,3	2393	1,8	3,4	13,3	4000	90

Output kW	Motor type	Product code	Efficiency IEC 60034-30-1: 2014				Current		Torque			Moment of inertia J = 1/4 GD ₂ kgm ₂	Weight kg	Sound pressure Level L _{PA} dB	
			Speed r/min	Full load 100%	3/4 load 75%	1/2 load 50%	Power factor Cos	I _n A	I _s /I _N	T _N Nm	T _i /T _N				T _b /T _N
3600 r/min = 2 poles			460 V 60Hz				COMPACT-design								
110	M3BP 280MLA 2	3GBP281410---R	3586	96,3	95,9	94,9	0,9	164	10,4	293	3,2	4,2	0,941	840	77
132	M3BP 280MLB 2	3GBP281420---R	3583	96,6	96,4	95,6	0,9	191	10,1	352	3,2	3,7	1,06	890	77
250	M3BP 315LKB 2	3GBP311820---R	3587	96,9	96,9	96,4	0,9	359	9,1	666	3,1	3,4	2,33	1540	81
560	M3BP 355LKB 2	3GBP351820---R	3586	96,9	96,6	95,8	0,9	801	10,1	1491	2,8	4,5	4,93	2460	89

Technical data

IE5 cast iron motors 460 V 60 Hz

IP 55 - IC 411 - Insulation class F, temperature rise class B

IE5 efficiency class according to IEC 60034-30-1; 2014

Output kW	Motor type	Product code	Efficiency IEC 60034-30-1: 2014				Current		Torque			Moment of inertia J = 1/4 GD ₂ kgm ₂	Weight kg	Sound pressure Level L _{PA} dB	
			Speed r/min	Full load 100%	>3/4 load 75%	1/2 load 50%	Power factor Cos	I _n A	I _s /I _N	T _N Nm	T _i /T _N				T _b /T _N
1800 r/min = 4 poles			460 V 60Hz				BASIC-design								
75	M3BP 280SMC 4	3GBP282230---R	1791	96,9	96,8	96,1	0,8	121	9,8	400	3,8	4,0	1,4	725	71
75	M3BP 280SMC 4	3GBP282230---R	1792	96,9	96,6	95,9	0,8	124	9,8	400	4,2	4,3	1,4	725	71
90	M3BP 280MLD 4	3GBP282440---R	1789	96,9	96,9	96,4	0,8	140	9,0	480	4,1	3,6	1,93	910	71
110	M3BP 315SMC 4	3GBP312230---R	1792	96,9	96,7	96,1	0,8	169	9,0	586	3,1	3,7	2,52	1065	72
132	M3BP 315SMD 4	3GBP312240---R	1791	97,2	97,2	96,8	0,8	205	8,4	704	2,9	3,5	2,51	1065	72
160	M3BP 315MLC 4	3GBP312430---R	1791	97,2	97,3	97,1	0,9	242	8,7	853	3,2	3,4	3,27	1270	72
200	M3BP 355SMB 4	3GBP352220---R	1793	97,2	97,1	96,7	0,9	301	8,5	1065	2,9	3,3	5,98	1780	71
200	M3BP 315LKC 4	3GBP312830---R	1794	97,2	97,0	96,3	0,8	306	10,3	1065	3,3	4,1	3,91	1600	76
250	M3BP 355SMC 4	3GBP352230---R	1794	97,4	97,2	96,4	0,8	392	9,4	1331	4,2	4,0	6,56	1820	74
315	M3BP 355SMD 4	3GBP352240---R	1792	97,4	97,4	97,0	0,8	488	8,0	1678	3,6	3,4	6,52	1820	74
355	M3BP 355MLA 4	3GBP352410---R	1793	97,4	97,2	96,5	0,9	540	9,4	1890	4,0	3,7	7,44	2140	82
400	M3BP 355MLB 4	3GBP352420---R	1792	97,4	97,4	97,0	0,9	608	9,4	2131	3,5	3,3	7,4	2140	82
450	M3BP 355LKA 4	3GBP352810---R	1794	97,4	97,2	96,5	0,8	700	8,4	2396	4,4	3,7	9,16	2500	82
500	M3BP 355LKB 4	3GBP352820---R	1793	97,4	97,3	96,7	0,8	777	8,2	2663	4,5	3,6	9,74	2580	82
560	M3BP 400LA 4	3GBP402510---R	1794	97,4	97,3	96,7	0,8	862	10,1	2982	3,3	3,6	12,6	3200	85
560	M3BP 400LKA 4	3GBP402810---R	1794	97,4	97,3	96,7	0,8	862	10,1	2982	3,3	3,6	12,6	3200	85
630	M3BP 400LB 4	3GBP402520---R	1793	97,4	97,4	97,0	0,9	952	9,7	3356	3,2	3,4	13,4	3300	85
630	M3BP 400LKB 4	3GBP402820---R	1793	97,4	97,4	97,0	0,9	952	9,7	3356	3,2	3,4	13,4	3300	85
710	M3BP 400LC 4	3GBP402530---R	1793	97,4	97,4	97,0	0,8	1087	8,3	3782	2,9	3,3	14,4	3300	85
710	M3BP 400LKC 4	3GBP402830---R	1793	97,4	97,4	97,0	0,8	1087	8,3	3782	2,9	3,3	14,4	3300	85
800	M3BP 450LA 4	3GBP452510---R	1793	97,4	97,4	96,9	0,8	1234	6,5	4261	1,5	3,3	20,8	4050	86
900	M3BP 450LB 4	3GBP452520---R	1793	97,4	97,4	97,0	0,8	1381	6,9	4794	1,5	3,2	24	4050	86
1000	M3BP 450LC 4	3GBP452530---R	1794	97,4	97,4	96,9	0,8	1554	7,7	5324	1,7	3,6	27,8	4350	86

Output kW	Motor type	Product code	Efficiency IEC 60034-30-1: 2014				Current		Torque			Moment of inertia J = 1/4 GD ₂ kgm ₂	Weight kg	Sound pressure Level L _{PA} dB	
			Speed r/min	Full load 100%	3/4 load 75%	1/2 load 50%	Power factor Cos	I _n A	I _s /I _N	T _N Nm	T _i /T _N				T _b /T _N
1800 r/min = 4 poles			460 V 60Hz				COMPACT-design								
250	M3BP 315LKD 4	3GBP312840---R	1792	97,4	97,4	97,1	0,9	378	8,7	1332	2,8	3,4	3,89	1600	76

Technical data

IE5 cast iron motors 460 V 60 Hz

IP 55 - IC 411 - Insulation class F, temperature rise class B

IE5 efficiency class according to IEC 60034-30-1; 2014

Output kW	Motor type	Product code	Efficiency IEC 60034-30-1: 2014				Current		Torque			Moment of inertia J = 1/4 GD ₂ kgm ₂	Weight kg	Sound pressure Level L _{PA} dB	
			Speed r/min	Full load 100%	>3/4 load 75%	1/2 load 50%	Power factor Cos	I _n A	I _s /I _N	T _N Nm	T _i /T _N				T _b /T _N
1200 r/min = 6 poles			460 V 60Hz				BASIC-design								
45	M3BP 280SMB 6	3GBP283220---R	1193	96,3	96,4	96,0	0,8	72,6	8,8	360	3,2	3,2	1,98	680	67
45	M3BP 280SMB 6	3GBP283220---R	1193	96,3	96,4	96,0	0,8	72,3	8,7	360	3,1	3,1	1,98	680	67
55	M3BP 280SMC 6	3GBP283230---R	1193	96,3	96,4	96,1	0,8	87,5	8,7	440	3,2	3,0	2,25	725	67
55	M3BP 280SMC 6	3GBP283230---R	1193	96,3	96,5	96,1	0,8	87,8	8,8	440	3,3	3,1	2,25	725	67
75	M3BP 315SMC 6	3GBP313230---R	1195	96,6	96,5	96,0	0,8	121	8,7	599	3,0	3,3	4,34	1000	71
90	M3BP 315SMD 6	3GBP313240---R	1195	96,6	96,6	96,1	0,8	144	8,6	719	3,0	3,2	4,81	1050	71
110	M3BP 315MLC 6	3GBP313430---R	1195	96,9	96,8	96,1	0,8	177	9,0	879	3,3	3,3	6,21	1280	72
132	M3BP 315LKB 6	3GBP313820---R	1195	96,9	96,9	96,4	0,8	217	8,3	1055	3,6	3,4	7,32	1560	72
160	M3BP 315LKD 6	3GBP313840---R	1195	96,9	96,9	96,5	0,8	263	8,2	1279	3,6	3,4	7,67	1600	72
160	M3BP 355SMB 6	3GBP353220---R	1196	96,9	96,8	96,3	0,8	265	8,6	1277	3,1	3,4	9,29	1760	75
200	M3BP 355SMC 6	3GBP353230---R	1196	96,9	96,9	96,4	0,8	329	8,1	1597	3,0	3,3	9,99	1830	75
250	M3BP 355MLB 6	3GBP353420---R	1195	97,2	97,3	97,0	0,8	407	8,8	1997	3,1	3,1	11,9	2170	75
315	M3BP 355LKB 6	3GBP353820---R	1195	97,2	97,2	96,9	0,8	503	6,9	2517	2,9	2,8	14,6	2600	76
355	M3BP 355LKC 6	3GBP353830---R	1196	97,2	97,1	96,7	0,8	581	8,1	2836	3,5	3,2	16,3	2800	76
400	M3BP 400LA 6	3GBP403510---R	1195	97,2	97,2	96,7	0,8	620	7,9	3195	2,7	3,2	18,9	3200	82
400	M3BP 400LKA 6	3GBP403810---R	1195	97,2	97,2	96,7	0,8	620	7,9	3195	2,7	3,2	18,9	2900	82
450	M3BP 400LB 6	3GBP403520---R	1196	97,2	97,1	96,5	0,8	741	8,8	3592	3,3	3,8	20,4	3300	82
450	M3BP 400LKB 6	3GBP403820---R	1196	97,2	97,1	96,5	0,8	741	8,8	3592	3,3	3,8	20,4	3300	82
500	M3BP 400LC 6	3GBP403530---R	1196	97,2	97,2	96,7	0,8	805	8,4	3993	3,2	3,5	20,4	3300	82
500	M3BP 400LKC 6	3GBP403830---R	1196	97,2	97,2	96,7	0,8	805	8,4	3993	3,2	3,5	20,4	3300	82
560	M3BP 400LD 6	3GBP403540---R	1195	97,2	97,2	96,9	0,8	869	7,9	4475	3,0	3,2	22	3400	82
560	M3BP 400LKD 6	3GBP403840---R	1195	97,2	97,2	96,9	0,8	869	7,9	4475	3,0	3,2	22	3400	82
630	M3BP 450LA 6	3GBP453510---R	1196	97,2	97,1	96,7	0,8	1018	7,9	5029	1,7	3,5	32,9	4250	85
710	M3BP 450LB 6	3GBP453520---R	1195	97,2	97,3	97,0	0,8	1108	7,5	5672	1,6	3,1	37,5	4500	85
800	M3BP 450LC 6	3GBP453530---R	1196	97,2	97,3	97,0	0,8	1261	7,0	6389	1,6	3,3	42	4800	85
900	M3BP 500LA 6	3GBP503510---R	1197	97,2	96,9	96,0	0,8	1482	7,6	7183	1,5	4,3	45,6	5800	94
950	M3BP 500LB 6	3GBP503520---R	1196	97,2	96,9	96,2	0,8	1490	7,3	7583	1,4	3,9	53,7	6200	94

Output kW	Motor type	Product code	Efficiency IEC 60034-30-1: 2014				Current		Torque			Moment of inertia J = 1/4 GD ₂ kgm ₂	Weight kg	Sound pressure Level L _{PA} dB	
			Speed r/min	Full load 100%	3/4 load 75%	1/2 load 50%	Power factor Cos	I _n A	I _s /I _N	T _N Nm	T _i /T _N				T _b /T _N
1200 r/min = 6 poles			460 V 60Hz				COMPACT-design								
75	M3BP 280MLD 6	3GBP283440---R	1193	96,6	96,7	96,4	0,8	119	9,2	600	3,8	3,3	3,12	910	67

Technical data

IE4 cast iron motors 460 V 60 Hz

IP 55 - IC 411 - Insulation class F, temperature rise class B

IE4 efficiency class according to IEC 60034-30-1; 2014

Output kW	Motor type	Product code	Efficiency IEC 60034-30-1: 2014					Current			Torque			Moment of inertia J = 1/4 GD ₂ kgm ₂	Weight kg	Sound pressure Level L _{PA} dB	
			Speed r/min	Full load 100%	3/4 load 75%	1/2 load 50%	Power factor Cos	I _n A	I _s /I _N	T _N Nm	T _I /T _N	T _B /T _N					
3600 r/min = 2 poles			460 V 60Hz					BASIC-design									
3	M3BP 100LKA 2	3GBP101810---M	3518	89,5	89,6	88,1	0,89	4,9	11,3	8,4	2,8	4,9	0,0087	57	57		
4	M3BP 112MB 2	3GBP111320---M	3492	89,5	90,3	89,9	0,90	6,2	10,3	11,7	2,5	4,6	0,0134	65,5	66		
5.5	M3BP 132SMB 2	3GBP131220---M	3540	90,2	90,5	89,4	0,90	8,1	8,6	14,8	2,0	4,0	0,0158	85,1	67		
7.5	M3BP 132SMC 2	3GBP131230---M	3537	91,7	92,2	91,5	0,92	12,0	10,3	21,6	2,7	5,1	0,0177	90,4	67		
11	M3BP 160MLA 2	3GBP161410---M	3558	92,4	92,4	91,1	0,90	16,6	9,9	29,5	3,1	4,5	0,0514	140,6	73		
15	M3BP 160MLB 2	3GBP161420---M	3559	92,4	92,3	91,1	0,90	22,5	10,8	40,2	3,6	4,8	0,0612	169,8	73		
18.5	M3BP 160MLC 2	3GBP161430---M	3555	93,0	93,2	92,6	0,89	27,9	9,7	50,4	4,0	4,8	0,079	179	71		
22	M3BP 180MLA 2	3GBP181410---M	3564	93,0	93,0	92,0	0,87	33,4	9,5	59,3	3,7	4,4	0,126	224	71		
30	M3BP 200MLA 2	3GBP201410---M	3568	93,6	94,1	92,0	0,87	44,5	10,6	80,3	3,3	4,2	0,217	309	76		
37	M3BP 200MLB 2	3GBP201420---M	3560	94,1	94,2	93,6	0,89	55,1	8,5	99,2	3,1	3,6	0,217	309	76		
45	M3BP 225SMA 2	3GBP221210---M	3575	94,5	94,1	92,9	0,87	67,7	9,2	120	3,7	4,1	0,323	395	78		
55	M3BP 250SMA 2	3GBP251210---M	3579	94,5	94,4	93,2	0,89	82,5	9,2	148	3,7	4,0	0,634	483	79		
75	M3BP 280SMB 2	3GBP281220---M	3582	95,0	94,6	93,3	0,87	113	8,2	200	2,6	3,2	0,9	665	80		
90	M3BP 280SMC 2	3GBP281230---M	3582	95,4	95,0	93,8	0,88	133	9,0	240	3,4	3,4	1,15	725	80		
110	M3BP 315SMB 2	3GBP311220---M	3584	95,4	94,9	93,5	0,88	165	7,5	293	1,9	2,9	1,4	940	80		
132	M3BP 315SMC 2	3GBP311230---M	3586	95,8	95,4	94,2	0,88	197	8,9	351	2,4	3,3	1,7	1025	80		
160	M3BP 315MLA 2	3GBP311410---M	3584	95,8	95,6	94,8	0,89	233	8,2	426	2,2	3,0	2,1	1190	80		
200	M3BP 315MLB 2	3GBP311420---M	3584	96,2	96,2	95,5	0,90	290	7,7	533	2,0	2,9	2,2	1220	80		
200	M3BP 355SMA 2	3GBP351210---M	3586	96,2	95,8	94,8	0,88	295	8,5	533	2,0	3,4	3	1600	86		
250	M3BP 355SMB 2	3GBP351220---M	3585	96,2	95,8	94,8	0,90	363	8,5	666	2,3	3,3	3,4	1680	86		
315	M3BP 355SMC 2	3GBP351230---M	3586	96,2	95,8	94,8	0,89	466	8,7	839	2,3	3,1	3,6	1750	86		
355	M3BP 355MLA 2	3GBP351410---M	3583	96,2	95,9	94,9	0,90	518	8,5	944	2,3	2,9	4,1	2000	86		
400	M3BP 355MLB 2	3GBP351420---M	3582	96,2	95,6	94,3	0,88	589	8,3	1066	2,3	3,2	4,1	2000	88		
450	M3BP 355MLC 2	3GBP351430---M	3585	96,2	95,8	94,8	0,90	650	8,9	1199	2,2	3,2	4,3	2080	88		
500	M3BP 355LKA 2	3GBP351810---M	3584	96,2	95,9	95,0	0,90	722	9,0	1332	2,4	4,3	4,8	2320	88		
560	M3BP 400LA 2	3GBP401510---M	3588	96,2	95,8	94,5	0,89	818	9,0	1490	2,3	3,8	7,9	2950	86		
560	M3BP 400LKA 2	3GBP401810---M	3588	96,2	95,8	94,5	0,89	818	9,0	1490	2,3	3,8	7,9	2950	86		
560	M3BP 355LKB 2	3GBP351820---M	3586	96,2	95,9	94,9	0,92	790	11,3	1492	2,4	4,5	5,2	2460	88		
630	M3BP 400LB 2	3GBP401520---M	3588	96,2	96,0	95,9	0,89	916	8,6	1676	3,0	4,5	8,2	2950	86		
630	M3BP 400LKB 2	3GBP401820---M	3588	96,2	96,0	95,9	0,89	916	8,6	1676	3,0	4,5	8,2	2950	86		
710	M3BP 400LC 2	3GBP401530---M	3588	96,2	96,0	95,2	0,90	1026	8,4	1890	2,9	4,0	9,3	3050	86		
780	M3BP 400LKC 2	3GBP401830---M	3587	96,2	95,9	94,8	0,90	1116	8,2	2076	2,5	3,5	9,3	3050	86		
800	M3BP 450LA 2	3GBP451510---M	3591	96,2	96,0	94,8	0,87	1188	8,0	2127	1,3	3,5	12,2	4000	90		
900	M3BP 450LB 2	3GBP451520---M	3591	96,2	96,0	95,1	0,85	1366	7,8	2393	1,5	3,4	13,5	4000	90		

Output kW	Motor type	Product code	Efficiency IEC 60034-30-1: 2014					Current			Torque			Moment of inertia J = 1/4 GD ₂ kgm ₂	Weight kg	Sound pressure Level L _{PA} dB	
			Speed r/min	Full load 100%	3/4 load 75%	1/2 load 50%	Power factor Cos	I _n A	I _s /I _N	T _N Nm	T _I /T _N	T _B /T _N					
3600 r/min = 2 poles			460 V 60Hz					COMPACT-design									
110	M3BP 280SMD 2	3GBP281240---M	3582	95,4	95,0	93,8	0,85	167	9,2	293	3,2	4,2	1,15	725	81		
132	M3BP 280MLA 2	3GBP281410---M	3582	95,8	94,0	92,9	0,87	196	9,0	351	3,4	4,0	1,4	840	84		
160	M3BP 280MLB 2	3GBP281420---M	3573	95,8	95,9	95,3	0,90	230	7,5	427	2,8	3,0	1,55	890	84		
250	M3BP 315LKB 2	3GBP311820---M	3583	96,2	96,2	95,8	0,91	359	9,0	666	2,6	3,0	2,9	1540	80		
315	M3BP 315LKC 2	3GBP311830---M	3583	96,2	96,0	95,0	0,89	467	10,1	839	3,4	3,6	3,3	1630	83		

Technical data

IE4 cast iron motors 460 V 60 Hz

IP 55 - IC 411 - Insulation class F, temperature rise class B

IE4 efficiency class according to IEC 60034-30-1; 2014

Output kW	Motor type	Product code	Efficiency IEC 60034-30-1: 2014				Current		Torque			Moment of inertia J = 1/4 GD ₂ kgm ₂	Weight kg	Sound pressure Level L _{PA} dB	
			Speed r/min	Full load 100%	>3/4 load 75%	1/2 load 50%	Power factor Cos	I _n A	I _s /I _N	T _N Nm	T _i /T _N				T _b /T _N
1800 r/min = 4 poles			460 V 60Hz				BASIC-design								
2.2	M3BP 100LKA 4	3GBP102810---M	1764	91,0	90,5	88,9	0,79	3,9	8,2	11,9	2,7	4,5	0,0233	57	58
3	M3BP 100LKB 4	3GBP102820---M	1765	91,0	91,0	89,8	0,76	5,4	9,5	16,4	3,3	4,5	0,0266	62	58
4	M3BP 112MB 4	3GBP112320---M	1768	91,0	91,3	90,1	0,75	7,3	9,0	21,8	3,5	4,8	0,0244	70,4	59
5.5	M3BP 132SMB 4	3GBP132220---M	1771	92,4	92,4	91,4	0,80	9,4	8,2	29,7	2,4	3,8	0,0425	93,4	64
7.5	M3BP 132SMC 4	3GBP132230---M	1769	92,4	92,5	91,6	0,75	13,6	9,4	40,7	3,4	4,4	0,0488	101	64
11	M3BP 160MLA 4	3GBP162410---M	1780	93,6	93,5	92,5	0,77	19,2	8,6	59,0	3,0	4,2	0,123	188	66
15	M3BP 160MLC 4	3GBP162430---M	1782	94,1	93,9	92,6	0,75	27,0	9,5	80,4	3,8	4,6	0,127	185	66
18.5	M3BP 180MLB 4	3GBP182420---M	1782	94,5	94,4	93,5	0,81	30,5	9,7	99,1	3,2	4,3	0,22	247	66
22	M3BP 180MLC 4	3GBP182430---M	1787	94,5	94,5	93,8	0,82	35,9	10,7	118	3,6	4,4	0,22	246,6	66
30	M3BP 200MLA 4	3GBP202410---M	1789	95,0	94,8	93,7	0,74	53,3	9,5	160	4,3	4,9	0,369	304	67
37	M3BP 225SMA 4	3GBP222210---M	1784	95,4	95,5	95,1	0,83	58,3	8,6	198	3,4	3,5	0,536	383	70
45	M3BP 225SMC 4	3GBP222230---M	1785	95,4	95,6	95,2	0,81	73,6	10,2	241	4,0	4,2	0,607	433	70
55	M3BP 250SMA 4	3GBP252210---M	1785	95,8	95,0	94,1	0,81	88,3	7,9	294	3,8	4,0	0,933	467	71
75	M3BP 280SMC 4	3GBP282230---M	1787	96,2	96,1	95,3	0,84	116	8,9	400	3,0	3,2	1,85	725	72
90	M3BP 280MLA 4	3GBP282410---M	1790	96,2	96,2	95,5	0,84	136	9,8	481	3,6	3,5	2,3	840	75
110	M3BP 315SMC 4	3GBP312230---M	1792	96,2	96,0	95,3	0,83	172	8,8	586	2,6	3,4	2,9	1000	71
132	M3BP 315SMD 4	3GBP312240---M	1791	96,5	96,3	95,6	0,84	206	9,0	704	2,8	3,6	3,2	1065	71
160	M3BP 315MLB 4	3GBP312420---M	1791	96,5	96,5	95,9	0,86	241	9,0	853	2,9	3,3	3,9	1220	71
200	M3BP 355SMA 4	3GBP352210---M	1792	96,5	96,2	95,4	0,87	301	8,3	1065	2,2	3,0	5,9	1610	77
250	M3BP 355SMB 4	3GBP352220---M	1792	96,8	96,6	96,0	0,86	381	8,8	1332	2,7	3,2	6,9	1780	77
315	M3BP 355SMC 4	3GBP352230---M	1791	96,8	96,6	96,1	0,85	479	8,5	1679	3,1	3,2	7,2	1820	77
355	M3BP 355MLA 4	3GBP352410---M	1792	96,8	96,6	96,0	0,86	542	9,0	1890	2,9	3,2	8,4	2140	81
400	M3BP 355MLB 4	3GBP352420---M	1791	96,8	96,8	96,2	0,85	609	8,5	2132	2,6	3,2	8,4	2140	82
450	M3BP 355MLC 4	3GBP352430---M	1791	96,8	96,8	96,2	0,85	685	8,2	2399	2,5	3,1	8,4	2140	82
500	M3BP 355LKA 4	3GBP352810---M	1791	96,8	96,3	95,2	0,85	763	8,0	2666	2,4	3,4	10	2500	83
630	M3BP 400LB 4	3GBP402520---M	1793	96,8	96,6	95,9	0,85	960	8,9	3355	2,2	3,3	16	3300	83
630	M3BP 400LKB 4	3GBP402820---M	1793	96,8	96,6	95,9	0,85	960	8,9	3355	2,2	3,3	16	3300	83
710	M3BP 400LC 4	3GBP402530---M	1792	96,8	96,6	96,0	0,84	1091	7,9	3784	2,5	3,3	17	3300	83
900	M3BP 450LB 4	3GBP452520---M	1792	96,8	96,3	96,0	0,85	1373	7,9	4794	1,3	3,1	25	4050	89
1000	M3BP 450LC 4	3GBP452530---M	1792	96,8	96,7	95,9	0,86	1505	7,2	5329	1,4	2,8	30	4350	89

Output kW	Motor type	Product code	Efficiency IEC 60034-30-1: 2014				Current		Torque			Moment of inertia J = 1/4 GD ₂ kgm ₂	Weight kg	Sound pressure Level L _{PA} dB	
			Speed r/min	Full load 100%	3/4 load 75%	1/2 load 50%	Power factor Cos	I _n A	I _s /I _N	T _N Nm	T _i /T _N				T _b /T _N
1800 r/min = 4 poles			460 V 60Hz				COMPACT-design								
110	M3BP 280MLB 4	3GBP282420---M	1790	96,2	95,9	95,1	0,80	180	10,8	587	4,4	4,4	2,5	890	78
132	M3BP 280MLC 4	3GBP282430---M	1790	96,5	96,2	95,4	0,79	216	9,3	704	4,1	4,4	2,5	890	78
200	M3BP 315LKB 4	3GBP312820---M	1791	96,5	96,5	95,9	0,87	301	8,7	1066	2,7	3,2	5	1480	77
250	M3BP 315LKC 4	3GBP312830---M	1791	96,8	96,8	96,4	0,86	376	8,9	1332	2,5	3,3	5,5	1600	77
315	M3BP 315LKE 4	3GBP312850---M	1790	96,8	96,9	96,7	0,84	487	8,2	1684	2,8	3,8	4,6	1540	76

Technical data

IE4 cast iron motors 460 V 60 Hz

IP 55 - IC 411 - Insulation class F, temperature rise class B

IE4 efficiency class according to IEC 60034-30-1; 2014

Output kW	Motor type	Product code	Efficiency IEC 60034-30-1: 2014					Current			Torque			Moment of inertia J = 1/4 GD ₂ kgm ₂	Weight kg	Sound pressure Level L _{PA} dB	
			Speed r/min	Full load 100%	>3/4 load 75%	1/2 load 50%	Power factor Cos	I _n A	I _s /I _N	T _N Nm	T _i /T _N	T _b /T _N					
1200 r/min = 6 poles			460 V 60Hz					BASIC-design									
1.5	M3BP 100LKB 6	3GBP103820---M	1175	89,5	88,8	87,1	0,70	3,1	7,0	12,2	2,2	4,0	0,0159	51	53		
2.2	M3BP 112MB 6	3GBP113320---M	1173	90,2	89,9	88,2	0,68	4,5	7,1	21,4	2,4	3,9	0,0198	63	57		
3	M3BP 132SMB 6	3GBP133220---M	1181	90,2	89,9	88,1	0,79	5,2	6,4	24,3	1,6	3,2	0,0347	85,3	67		
4	M3BP 132SMC 6	3GBP133230---M	1180	90,2	90,1	88,5	0,79	7,0	6,3	32,4	1,6	3,2	0,0385	90	66		
5.5	M3BP 132SMD 6	3GBP133240---M	1176	91,7	92,1	91,2	0,73	10,3	6,4	45,0	1,8	3,2	0,0422	97,4	66		
11	M3BP 160MLB 6	3GBP163420---M	1184	93,0	93,7	93,1	0,74	20,1	8,0	88,7	2,0	3,9	0,133	189	63		
15	M3BP 180MLA 6	3GBP183410---M	1186	93,0	92,7	91,1	0,79	29,1	7,9	122	2,9	4,4	0,254	240	63		
18.5	M3BP 200MLA 6	3GBP203410---M	1192	94,1	94,0	93,1	0,78	31,6	9,2	148	3,5	4,1	0,531	306	67		
22	M3BP 200MLC 6	3GBP203430---M	1191	94,1	93,3	92,8	0,75	39,0	8,4	176	2,1	2,6	0,545	311	67		
30	M3BP 225SMA 6	3GBP223210---M	1190	95,0	94,9	94,1	0,75	52,6	7,7	241	3,4	3,8	0,813	369	67		
37	M3BP 250SMA 6	3GBP253210---M	1193	95,0	95,1	94,5	0,74	65,8	9,2	297	4,1	4,5	1,49	457	67		
45	M3BP 280SMB 6	3GBP283220---M	1193	95,4	95,3	94,4	0,85	70,6	7,9	361	2,6	2,9	2,2	680	68		
55	M3BP 280SMC 6	3GBP283230---M	1190	95,4	95,4	94,6	0,85	86,2	7,8	441	2,6	2,9	2,85	725	68		
75	M3BP 315SMC 6	3GBP313230---M	1195	95,8	95,5	94,7	0,82	121	7,9	600	2,5	3,1	4,9	1000	70		
90	M3BP 315SMD 6	3GBP313240---M	1195	95,8	95,6	94,9	0,80	149	8,2	719	2,7	3,2	4,9	1040	70		
110	M3BP 315MLB 6	3GBP313420---M	1194	96,2	96,0	95,4	0,81	177	7,9	880	2,6	3,0	6,3	1200	71		
132	M3BP 315LKA 6	3GBP313810---M	1194	96,2	96,0	95,5	0,81	215	7,9	1055	2,7	3,0	7,3	1410	71		
160	M3BP 355SMB 6	3GBP353220---M	1195	96,2	96,0	95,3	0,81	260	7,9	1278	2,3	3,0	9,7	1680	76		
200	M3BP 355SMC 6	3GBP353230---M	1196	96,2	95,7	95,0	0,82	320	8,3	1598	2,5	3,1	11,3	1820	76		
250	M3BP 355MLB 6	3GBP353420---M	1195	96,5	96,5	95,8	0,82	401	9,2	1997	2,3	3,0	13,5	2180	76		
315	M3BP 355LKA 6	3GBP353810---M	1195	96,5	96,5	95,9	0,83	500	7,9	2516	2,6	2,9	15,5	2500	79		
355	M3BP 355LKB 6	3GBP353820---M	1195	96,5	96,2	95,4	0,80	584	8,8	2835	3,0	3,2	16,5	2600	79		
400	M3BP 400LA 6	3GBP403510---M	1195	96,5	96,4	95,7	0,80	639	8,6	3196	3,0	3,5	17	2900	79		
400	M3BP 400LKA 6	3GBP403810---M	1195	96,5	96,4	95,7	0,80	639	8,6	3196	3,0	3,5	17	2900	79		
450	M3BP 400LB 6	3GBP403520---M	1196	96,5	96,0	94,9	0,81	726	9,4	3593	3,6	4,0	22	3300	79		
450	M3BP 400LKB 6	3GBP403820---M	1196	96,5	96,0	94,9	0,81	726	9,4	3593	3,6	4,0	22	3300	79		
500	M3BP 400LC 6	3GBP403530---M	1195	96,5	96,2	95,2	0,82	793	8,9	3995	3,4	3,7	22	3300	79		
500	M3BP 400LKC 6	3GBP403830---M	1195	96,5	96,2	95,2	0,82	793	8,9	3995	3,4	3,7	22	3300	79		
630	M3BP 400LD 6	3GBP403540---M	1193	96,5	96,5	95,9	0,86	952	7,5	5042	2,3	2,8	24	3400	79		
630	M3BP 400LKD 6	3GBP403840---M	1193	96,5	96,5	95,9	0,86	952	7,5	5042	2,3	2,8	24	3400	79		
710	M3BP 450LB 6	3GBP453520---M	1196	96,5	96,3	95,6	0,85	1085	8,2	5671	1,4	2,9	37	4500	85		
800	M3BP 450LC 6	3GBP453530---M	1195	96,5	96,4	95,7	0,83	1254	8,4	6393	1,4	3,3	41	4800	85		
900	M3BP 500LA 6	3GBP503510---M	1196	96,5	96,0	95,1	0,78	1488	6,9	7186	1,4	4,0	50,8	5800	94		
950	M3BP 500LB 6	3GBP503520---M	1197	96,5	96,0	95,1	0,79	1550	7,8	7579	1,6	4,4	59,6	6200	94		

Output kW	Motor type	Product code	Efficiency IEC 60034-30-1: 2014					Current			Torque			Moment of inertia J = 1/4 GD ₂ kgm ₂	Weight kg	Sound pressure Level L _{PA} dB	
			Speed r/min	Full load 100%	3/4 load 75%	1/2 load 50%	Power factor Cos	I _n A	I _s /I _N	T _N Nm	T _i /T _N	T _b /T _N					
1200 r/min = 6 poles			460 V 60Hz					COMPACT-design									
75	M3BP 280SMD 6	3GBP283240---M	1192	95,8	96,0	95,5	0,81	122	6,9	603	3,0	3,1	2,5	730	67		
160	M3BP 315LKC 6	3GBP313830---M	1195	96,2	96,0	95,3	0,81	259	8,4	1279	3,0	3,2	9,2	1600	71		
200	M3BP 315LKE 6	3GBP313850---M	1194	96,2	96,1	95,5	0,80	322	8,0	1599	2,5	3,1	9,2	1600	79		

Technical data

IE3 cast iron motors 460 V 60 Hz

IP 55 - IC 411 - Insulation class F, temperature rise class B

IE3 efficiency class according to IEC 60034-30-1; 2014

Output kW	Motor type	Product code	Efficiency IEC 60034-30-1: 2014				Current		Torque			Moment of inertia J = 1/4 GD ₂ kgm ₂	Weight kg	Sound pressure Level L _{PA} dB	
			Speed r/min	Full load 100%	3/4 load 75%	1/2 load 50%	Power factor Cos	I _n A	I _s /I _N	T _N Nm	T _i /T _N				T _b /T _N
3600 r/min = 2 poles			460 V 60Hz				BASIC-design								
0.37	M3BP 71 MC 2	3GBP071330---K	3360	73,4	72,5	68,2	0,74	6,0	6,0	1,0	2,8	3,5	0,00088	10,0	61,0
0.55	M3BP 71ME 2	3GBP071350---K	3386	76,8	76,7	74,0	0,81	1,10	8,4	1,55	3,3	3,9	0,00045	11	59
0.75	M3BP 80MD 2	3GBP081340---K	3502	77,0	75,2	70,0	0,72	1,56	8,9	2,0	4,3	5,2	0,0008	18	61
1.1	M3BP 80MG 2	3GBP081370---K	3500	84,0	83,0	80,2	0,78	2,0	9,9	3,0	3,6	5,3	0,001	19	60
1.5	M3BP 90LB 2	3GBP091520---K	3522	85,5	85,3	84,0	0,88	2,4	9,6	4,0	2,9	3,9	0,0027	31	65
2.2	M3BP 90LC 2	3GBP091530---K	3517	86,5	87,1	85,8	0,88	3,5	9,9	5,9	3,2	4,2	0,0032	35	65
3	M3BP 100LKA 2	3GBP101810---K	3512	88,5	88,7	87,2	0,89	4,7	9,9	8,1	3,5	4,6	0,0057	50	65
4	M3BP 112MG 2	3GBP111370---K	3500	88,5	88,9	87,9	0,90	6,2	10,0	10,9	3,6	4,8	0,0104	56	71
5.5	M3BP 132SMF 2	3GBP131260---K	3519	89,5	89,4	88,7	0,90	8,4	9,1	14,9	2,5	3,9	0,0154	77	74
7.5	M3BP 132SMG 2	3GBP131270---K	3524	90,2	90,7	90,0	0,90	11,4	9,6	20,3	3,1	4,5	0,0173	77	73
11	M3BP 160MLA 2	3GBP161410---K	3549	91,0	91,1	89,9	0,91	16,6	8,7	29,5	2,7	3,9	0,057	141	75
15	M3BP 160MLB 2	3GBP161420---K	3554	91,0	90,4	89,6	0,89	22,7	8,5	40,3	3,8	4,8	0,063	170	74
18.5	M3BP 160MLC 2	3GBP161430---K	3555	92,9	93,1	92,1	0,89	27,9	10,5	49,6	3,8	4,7	0,076	183	75
22	M3BP 180MLA 2	3GBP181410---K	3560	91,7	91,7	90,4	0,89	33,0	9,2	59,0	4,1	4,7	0,11	205	77
30	M3BP 200MLA 2	3GBP201410---K	3567	92,4	92,2	91,0	0,87	46,1	9,0	80,3	3,2	4,0	0,159	289	82
37	M3BP 200MLB 2	3GBP201420---K	3564	93,0	92,8	91,1	0,89	55,8	9,2	99,1	3,1	3,7	0,196	314	76
45	M3BP 225SMA 2	3GBP221210---K	3570	93,6	93,1	91,5	0,89	67,4	7,8	120	2,8	3,7	0,296	335	79
55	M3BP 250SMA 2	3GBP251210---K	3569	93,6	93,1	91,6	0,90	82,7	7,9	147	2,3	3,3	0,426	452	81
75	M3BP 280SMB 2	3GBP281220---K	3581	94,1	93,8	92,5	0,87	113	7,6	200	2,4	3,1	0,72	685	74
90	M3BP 280SMC 2	3GBP281230---K	3578	95,0	94,7	93,7	0,88	134	7,6	240	2,4	3,0	0,99	710	77
110	M3BP 315SMB 2	3GBP311220---K	3584	95,0	94,7	93,5	0,87	166	6,7	293	1,6	2,5	1,2	955	81
132	M3BP 315SMC 2	3GBP311230---K	3585	95,4	95,2	94,0	0,87	198	7,3	351	2,0	3,2	1,5	980	81
160	M3BP 315MLA 2	3GBP311410---K	3585	95,4	95,0	93,6	0,87	242	8,3	426	2,2	3,1	1,6	1100	81
200	M3BP 355SMA 2	3GBP351210---K	3586	95,8	95,4	94,3	0,88	295	8,5	533	2,0	3,4	3	1600	86
250	M3BP 355SMB 2	3GBP351220---K	3585	95,8	95,3	94,0	0,89	370	8,6	665	1,8	3,7	3	1680	86
315	M3BP 355SMC 2	3GBP351230---K	3582	95,8	95,5	94,3	0,89	466	7,8	839	2,2	3,3	3,4	1750	86
355	M3BP 355MLA 2	3GBP351410---K	3586	95,8	95,3	94,2	0,88	528	8,1	945	2,2	3,3	3,6	2000	88
400	M3BP 355MLB 2	3GBP351420---K	3582	95,8	95,2	93,8	0,88	589	8,3	1066	2,3	3,2	4,1	2000	88
450	M3BP 355MLC 2	3GBP351430---K	3585	95,8	95,4	94,3	0,90	650	8,9	1199	2,2	3,2	4,3	2080	88
500	M3BP 355LKA 2	3GBP351810---K	3584	95,8	95,5	94,5	0,90	722	9,0	1332	2,4	4,3	4,8	2320	88
560	M3BP 400LA 2	3GBP401510---K	3588	95,8	95,4	94,0	0,89	818	9,0	1490	2,3	3,8	7,9	2950	86
560	M3BP 400LKA 2	3GBP401810---K	3588	95,8	95,4	94,0	0,89	818	9,0	1490	2,3	3,8	7,9	2950	86
560	M3BP 355LKB 2	3GBP351820---K	3584	95,8	95,5	94,5	0,90	808	9,6	1492	2,8	4,5	5,2	2460	88
630	M3BP 400LB 2	3GBP401520---K	3588	95,8	95,7	95,5	0,89	916	8,6	1676	3,0	4,5	8,2	3050	86
630	M3BP 400LKB 2	3GBP401820---K	3588	95,8	95,7	95,5	0,89	916	8,6	1676	3,0	4,5	8,2	3050	86
710	M3BP 400LC 2	3GBP401530---K	3588	95,8	95,7	94,8	0,90	1026	8,4	1890	2,9	4,0	9,3	3300	86
710	M3BP 400LKC 2	3GBP401830---K	3588	95,8	95,7	94,8	0,90	1026	8,4	1890	2,9	4,0	9,3	3300	86
800	M3BP 450LA 2	3GBP451510---K	3591	95,8	95,5	94,2	0,87	1188	8,0	2127	1,3	3,5	12,2	4000	90
900	M3BP 450LB 2	3GBP451520---K	3591	95,8	95,5	94,6	0,85	1366	7,8	2393	1,5	3,4	13,5	4200	90

Output kW	Motor type	Product code	Efficiency IEC 60034-30-1: 2014						Current			Torque			Moment of inertia J = 1/4 GD ₂ kgm ₂	Weight kg	Sound pressure Level L _{PA} dB
			Speed r/min	Full load 100%	3/4 load 75%	1/2 load 50%	Power factor Cos	I _n A	I _s /I _N	T _N Nm	T _i /T _N	T _b /T _N					
3600 r/min = 2 poles			460 V 60Hz						COMPACT-design								
22	M3BP 160MLD 2	3GBP161440-...K	3552	91,7	92,0	91,2	0,90	32,9	9,7	59,2	3,5	4,2	0,071	174	78		
30	M3BP 180MLB 2	3GBP181420-...K	3563	93,3	93,5	92,9	0,89	45,7	10,0	80,4	3,3	4,3	0,104	215	78		
37	M3BP 180MLC 2	3GBP181430-...K	3564	93,0	93,2	92,7	0,86	57,0	9,7	99,1	3,8	4,7	0,117	229	77		
45	M3BP 200MLC 2	3GBP201430-...K	3563	93,6	93,9	93,7	0,89	66,8	8,7	121	3,2	3,7	0,216	305	80		
55	M3BP 225SMB 2	3GBP221220-...K	3575	93,6	93,6	92,7	0,86	84,5	8,1	147	3,4	3,7	0,299	355	82		
75	M3BP 225SMC 2	3GBP221230-...K	3572	94,1	94,3	93,5	0,88	114	8,4	201	3,2	3,8	0,362	408	82		
75	M3BP 250SMB 2	3GBP251220-...K	3575	94,1	94,1	93,1	0,90	110	9,0	200	3,0	3,6	0,644	479	85		
90	M3BP 250SMC 2	3GBP251230-...K	3578	95,0	94,9	94,1	0,87	136	9,6	240	3,1	4,2	0,514	495	84		
110	M3BP 280SMD 2	3GBP281240-...K	3581	95,0	94,6	93,3	0,88	165	8,9	292	2,5	3,3	1,15	725	82		
132	M3BP 280MLA 2	3GBP281410-...K	3579	95,4	95,1	93,9	0,88	196	8,5	351	2,9	3,6	1,4	840	83		
160	M3BP 280MLB 2	3GBP281420-...K	3578	95,4	95,2	94,3	0,89	236	8,5	426	2,9	3,5	1,55	890	83		
200	M3BP 315MLB 2	3GBP311420-...K	3585	95,8	95,4	94,2	0,88	298	8,7	533	2,6	3,4	1,9	1220	84		
250	M3BP 315LKB 2	3GBP311820-...K	3585	95,8	95,5	94,3	0,91	360	8,8	666	2,6	3,7	2,6	1540	84		
315	M3BP 315LKC 2	3GBP311830-...K	3583	95,8	95,5	94,4	0,89	467	10,1	839	3,4	3,6	3,3	1630	83		

Technical data

IE3 cast iron motors 460 V 60 Hz

IP 55 - IC 411 - Insulation class F, temperature rise class B
IE3 efficiency class according to IEC 60034-30-1; 2014

Output kW	Motor type	Product code	Efficiency IEC 60034-30-1: 2014				Current			Torque			Moment of inertia J = 1/4 GD ₂ kgm ₂	Weight kg	Sound pressure Level L _{PA} dB	
			Speed r/min	Full load 100%	>3/4 load 75%	1/2 load 50%	Power factor Cos	I _n A	I _s /I _N	T _N Nm	T _i /T _N	T _b /T _N				
1800 r/min = 4 poles			460 V 60Hz				BASIC-design									
0.25	M3BP 71MD 4	3GBP072340---K	1727	73,4	73,4	70,4	0,77	0,53	5,8	1,38	2,4	3,2	0,0009	11	48	
0.37	M3BP 71MLE 4	3GBP072450---K	1740	78,2	77,5	74,4	0,73	0,81	6,9	2,0	3,1	4,0	0,00122	15	48	
0.55	M3BP 80MLD 4	3GBP082440---K	1747	81,1	81,2	78,9	0,79	1,03	7,6	3,0	2,7	4,0	0,0028	20	48	
0.75	M3BP 90L 4	3GBP092500---K	1754	83,5	82,2	78,4	0,76	1,45	9,3	4,1	4,2	5,2	0,0056	30	56	
0.75	M3BP 80MLG 4	3GBP082470---K	1748	83,5	82,2	79,0	0,74	1,48	9,5	4,0	3,5	4,5	0,0027	22	57	
1.1	M3BP 90LC 4	3GBP092530---K	1749	86,5	85,4	82,5	0,77	2,0	8,4	6,0	3,7	4,6	0,0055	33	56	
1.5	M3BP 90LD 4	3GBP092540---K	1748	86,5	85,1	82,0	0,75	2,9	9,5	8,1	4,0	5,0	0,0055	34	58	
2.2	M3BP 100LKA 4	3GBP102810---K	1760	89,5	89,2	87,4	0,81	3,8	10,2	11,9	3,3	4,7	0,0144	49	57	
3	M3BP 100LKB 4	3GBP102820---K	1759	89,5	89,3	87,4	0,81	5,2	10,4	16,3	3,8	4,9	0,0144	49	57	
4	M3BP 112MG 4	3GBP112370---K	1755	89,5	89,9	88,8	0,75	7,4	9,3	21,7	3,5	4,9	0,018	52	67	
5.5	M3BP 132SMF 4	3GBP132260---K	1767	91,7	92,0	91,4	0,80	9,4	8,3	29,7	2,4	3,9	0,0401	87	70	
7.5	M3BP 132SMG 4	3GBP132270---K	1766	91,7	91,6	90,8	0,79	13,0	8,7	40,5	2,6	3,9	0,0414	81	69	
11	M3BP 160MLA 4	3GBP162410---K	1780	92,4	92,2	90,9	0,80	18,9	8,7	59,1	3,4	3,7	0,11	188	68	
15	M3BP 160MLB 4	3GBP162420---K	1780	93,0	92,7	91,4	0,82	24,7	9,5	80,5	3,3	4,1	0,135	187	67	
18.5	M3BP 180MLA 4	3GBP182410---K	1783	93,6	93,7	92,9	0,82	30,3	8,4	99,0	3,1	3,5	0,219	235	68	
22	M3BP 180MLB 4	3GBP182420---K	1783	93,8	94,2	93,7	0,82	35,8	9,3	117	3,0	3,4	0,217	235	66	
30	M3BP 200MLA 4	3GBP202410---K	1785	94,1	94,0	93,1	0,84	47,7	8,2	161	3,2	3,4	0,385	319	69	
37	M3BP 225SMA 4	3GBP222210---K	1786	94,5	94,4	93,5	0,81	61,2	8,5	195	3,8	4,0	0,433	398	78	
45	M3BP 225SMB 4	3GBP222220---K	1784	95,0	95,0	94,0	0,83	71,8	8,8	241	2,9	4,7	0,525	398	72	
55	M3BP 250SMA 4	3GBP252210---K	1787	95,4	95,5	94,8	0,84	85,8	9,1	293	3,3	3,7	0,933	476	71	
75	M3BP 280SMB 4	3GBP282220---K	1785	95,4	95,2	94,1	0,84	117	7,4	401	2,5	3,1	1,17	665	75	
90	M3BP 280SMC 4	3GBP282230---K	1786	95,4	95,2	94,2	0,85	139	8,2	481	2,7	3,2	1,45	725	75	
110	M3BP 315SMC 4	3GBP312230---K	1790	95,8	95,7	94,9	0,84	172	7,6	587	2,3	3,3	2,43	950	74	
132	M3BP 315SMD 4	3GBP312240---K	1790	96,2	96,2	95,5	0,84	205	7,7	705	2,4	3,0	2,9	1020	74	
160	M3BP 315MLB 4	3GBP312420---K	1790	96,2	96,2	95,5	0,84	249	7,8	854	2,3	3,3	3,2	1115	74	
200	M3BP 355SMA 4	3GBP352210---K	1792	96,2	95,9	95,0	0,87	301	8,3	1065	2,2	3,0	5,9	1610	77	
250	M3BP 355SMB 4	3GBP352220---K	1792	96,2	95,9	95,0	0,85	380	7,3	1333	2,2	3,2	5,7	1780	81	
315	M3BP 355SMC 4	3GBP352230---K	1793	96,2	96,0	95,1	0,86	478	7,6	1679	2,5	3,5	6,7	1820	81	
355	M3BP 355MLA 4	3GBP352410---K	1791	96,2	95,9	95,1	0,86	541	7,2	1893	2,4	3,1	7,2	2140	81	
400	M3BP 355MLB 4	3GBP352420---K	1791	96,2	96,1	95,3	0,86	615	7,8	2132	2,5	2,9	8,4	2140	83	
450	M3BP 355MLC 4	3GBP352430---K	1791	96,2	95,9	95,1	0,85	688	7,8	2401	2,5	2,8	8,4	2140	83	
500	M3BP 355LKA 4	3GBP352810---K	1791	96,2	95,7	94,4	0,85	763	8,0	2666	2,4	3,4	10	2500	83	
560	M3BP 355LKB 4	3GBP352820---K	1791	96,2	95,9	95,3	0,85	858	8,5	2988	2,8	2,9	10,6	2600	83	
560	M3BP 400LA 4	3GBP402510---K	1792	96,2	96,1	95,3	0,84	863	7,8	2985	2,7	3,1	15	3200	83	
560	M3BP 400LKA 4	3GBP402810---K	1792	96,2	96,1	95,3	0,84	863	7,8	2985	2,7	3,1	15	3200	83	
630	M3BP 400LB 4	3GBP402520---K	1792	96,2	96,1	95,4	0,85	959	8,9	3358	2,2	3,3	16	3300	83	
630	M3BP 400LKB 4	3GBP402820---K	1792	96,2	96,1	95,4	0,85	959	8,9	3358	2,2	3,3	16	3300	83	
710	M3BP 400LC 4	3GBP402530---K	1792	96,2	96,1	95,3	0,84	1091	7,9	3784	2,5	3,3	17	3400	83	
710	M3BP 400LKC 4	3GBP402830---K	1792	96,2	96,1	95,3	0,84	1091	7,9	3784	2,5	3,3	17	3400	83	
800	M3BP 450LA 4	3GBP452510---K	1792	96,2	96,0	95,4	0,86	1256	6,5	4263	1,3	3,1	23	4050	89	
900	M3BP 450LB 4	3GBP452520---K	1792	96,2	95,7	95,3	0,85	1373	7,9	4794	1,3	3,1	25	4350	89	
1000	M3BP 450LC 4	3GBP452530---K	1792	96,2	96,1	95,1	0,86	1505	7,2	5329	1,4	2,8	30	4700	89	

Output kW	Motor type	Product code	Efficiency IEC 60034-30-1: 2014				Current		Torque			Moment of inertia J = 1/4 GD ₂ kgm ₂	Weight kg	Sound pressure Level L _{PA} dB	
			Speed r/min	Full load 100%	3/4 load 75%	1/2 load 50%	Power factor Cos	I _n A	I _s /I _N	T _N Nm	T _v /T _N				T _b /T _N
1800 r/min = 4 poles			460 V 60Hz				COMPACT-design								
18.5	M3BP 160MLC 4	3GBP162430-...K	1778	93,6	93,6	92,7	0,76	32,4	8,2	99,3	3,8	4,0	0,121	180	70
28	M3BP 180MLC 4	3GBP182430-...K	1786	94,1	93,7	92,4	0,77	48,3	9,6	150	3,4	4,1	0,191	235	65
37	M3BP 200MLB 4	3GBP202420-...K	1785	94,5	94,3	93,4	0,81	60,5	9,1	198	3,5	3,6	0,362	305	71
49	M3BP 225SMC 4	3GBP222230-...K	1787	95,0	94,8	93,9	0,82	78,9	10,7	262	3,8	4,1	0,532	391	74
75	M3BP 250SMB 4	3GBP252220-...K	1785	95,4	95,4	94,7	0,81	121	8,5	403	3,8	3,7	0,933	464	76
110	M3BP 280SMD 4	3GBP282240-...K	1787	95,8	95,8	95,1	0,83	172	7,7	588	2,9	3,3	1,95	750	80
132	M3BP 280MLA 4	3GBP282410-...K	1786	96,2	96,2	95,8	0,84	206	7,7	705	2,9	3,1	2,3	840	78
160	M3BP 280MLB 4	3GBP282420-...K	1786	96,2	96,3	95,8	0,83	252	8,3	855	3,1	3,2	2,5	890	78
200	M3BP 315LKB 4	3GBP312820-...K	1788	96,2	96,3	95,9	0,86	305	7,8	1068	2,6	3,3	3,4	1480	77
250	M3BP 315LKC 4	3GBP312830-...K	1790	96,2	96,1	95,5	0,84	389	8,5	1335	2,7	3,5	4,4	1460	81
280	M3BP 315LKD 4	3GBP312840-...K	1789	96,2	96,1	95,5	0,84	437	9,2	1494	3,2	3,4	5	1520	81
315	M3BP 315LKE 4	3GBP312850-...K	1790	96,2	96,2	95,6	0,84	488	7,8	1681	3,2	3,8	5,5	1600	81

Technical data

IE3 cast iron motors 460 V 60 Hz

IP 55 - IC 411 - Insulation class F, temperature rise class B

IE3 efficiency class according to IEC 60034-30-1; 2014

Output kW	Motor type	Product code	Efficiency IEC 60034-30-1: 2014					Current		Torque			Moment of inertia J = 1/4 GD ₂ kgm ₂	Weight kg	Sound pressure Level L _{PA} dB	
			Speed r/min	Full load 100%	>3/4 load 75%	1/2 load 50%	Power factor Cos	I _n A	I _s /I _N	T _N Nm	T _i /T _N	T _b /T _N				
1200 r/min = 6 poles			460 V 60Hz					BASIC-design								
0.37	M3BP 80MD 6	3GBP083340---K	1138	75,3	74,7	71,3	0,66	0,89	6,1	3,1	3,2	3,5	0,0028	16	50	
0.75	M3BP 90LG 6	3GBP093570---K	1146	82,5	82,5	80,1	0,72	1,60	5,5	6,3	2,6	3,2	0,0072	34	47	
1.1	M3BP 100LKG 6	3GBP103870---K	1171	87,5	87,5	85,8	0,66	2,3	4,6	9,0	1,3	2,7	0,0025	47	52	
1.5	M3BP 100LKH 6	3GBP103880---K	1171	88,5	87,1	83,6	0,61	3,5	7,7	12,3	3,5	4,7	0,0138	47	52	
1.5	M3BP 112MH 6	3GBP113380---K	1174	88,5	88,0	85,9	0,62	3,4	7,5	12,2	3,0	5,2	0,0196	53	69	
2.2	M3BP 132SMC 6	3GBP133230---K	1180	89,5	88,9	86,7	0,68	4,5	6,5	17,8	2,1	3,3	0,0416	81	60	
2.2	M3BP 112MJ 6	3GBP113390---K	1172	89,5	89,6	88,3	0,66	4,6	7,3	17,9	2,5	4,0	0,0187	53	71	
3	M3BP 132SMD 6	3GBP133240---K	1179	89,5	89,0	87,0	0,68	6,1	6,5	24,0	1,4	3,1	0,0416	82	60	
4	M3BP 132SMG 6	3GBP133270---K	1177	89,5	89,3	87,8	0,68	8,1	6,3	32,0	2,3	3,2	0,0416	82	60	
5.5	M3BP 132SMH 6	3GBP133280---K	1169	91,0	91,2	90,3	0,72	10,6	5,7	44,7	2,0	3,1	0,0654	79	60	
7.5	M3BP 160MLA 6	3GBP163410---K	1182	91,0	91,1	89,8	0,76	13,5	8,6	60,5	1,8	3,7	0,114	172	63	
11	M3BP 160MLB 6	3GBP163420---K	1183	91,7	91,7	90,5	0,73	20,6	9,4	88,7	2,3	4,4	0,131	199	63	
15	M3BP 180MLA 6	3GBP183410---K	1183	91,7	91,3	89,7	0,75	27,1	6,0	121	1,8	3,1	0,225	234	63	
18.5	M3BP 200MLA 6	3GBP203410---K	1191	93,0	92,8	91,7	0,77	32,3	8,6	148	2,9	3,6	0,448	291	67	
22	M3BP 200MLB 6	3GBP203420---K	1191	93,0	93,0	91,8	0,78	37,7	8,8	176	2,9	3,6	0,531	318	67	
30	M3BP 225SMA 6	3GBP223210---K	1191	94,1	94,2	93,4	0,80	49,9	8,9	240	3,2	3,5	0,813	392	67	
37	M3BP 250SMA 6	3GBP253210---K	1192	94,1	94,3	93,6	0,82	59,9	8,6	296	3,0	3,2	1,49	467	67	
45	M3BP 280SMB 6	3GBP283220---K	1192	94,5	94,3	93,1	0,83	72,0	8,4	360	2,9	3,3	1,87	645	75	
55	M3BP 280SMC 6	3GBP283230---K	1193	94,5	94,4	93,5	0,84	87,0	8,6	441	3,0	3,2	2,57	700	74	
75	M3BP 315SMC 6	3GBP313230---K	1195	95,0	95,0	94,2	0,84	118	7,7	600	2,0	2,9	4,1	850	78	
90	M3BP 315SMD 6	3GBP313240---K	1195	95,0	94,8	93,8	0,84	143	8,0	720	2,2	3,3	4,6	990	79	
110	M3BP 315MLB 6	3GBP313420---K	1194	95,8	95,9	95,5	0,82	176	7,6	880	2,2	3,1	5	1080	78	
132	M3BP 315LKA 6	3GBP313810---K	1196	95,8	95,6	94,7	0,82	211	8,5	1055	2,5	3,3	6,3	1300	72	
160	M3BP 355SMB 6	3GBP353220---K	1193	95,8	95,8	95,0	0,82	257	7,6	1281	2,6	2,8	7,9	1540	78	
200	M3BP 355SMC 6	3GBP353230---K	1193	95,8	95,8	95,3	0,82	320	7,7	1600	2,8	2,7	9,7	1690	78	
250	M3BP 355MLB 6	3GBP353420---K	1194	95,8	95,6	94,7	0,81	405	8,3	1999	3,0	3,2	11,3	2010	80	
315	M3BP 355LKA 6	3GBP353810---K	1193	95,8	95,6	94,7	0,82	499	8,0	2521	2,8	3,0	14,6	2390	83	
355	M3BP 355LKB 6	3GBP353820---K	1194	95,8	95,7	94,8	0,81	572	8,7	2844	3,0	3,2	15,5	2540	80	
400	M3BP 400LA 6	3GBP403510---K	1194	95,8	95,6	94,8	0,82	637	8,2	3200	2,4	3,0	17	2900	79	
400	M3BP 400LKA 6	3GBP403810---K	1194	95,8	95,6	94,8	0,82	637	8,2	3200	2,4	3,0	17	2900	79	
400	M3BP 355LKC 6	3GBP353830---K	1193	95,8	95,5	94,6	0,82	639	7,5	3204	2,7	2,7	16,5	2600	80	
450	M3BP 400LB 6	3GBP403520---K	1194	95,8	95,6	94,7	0,82	713	7,9	3598	2,5	2,9	20,5	3150	79	
450	M3BP 400LKB 6	3GBP403820---K	1194	95,8	95,6	94,7	0,82	713	7,9	3598	2,5	2,9	20,5	3150	79	
500	M3BP 400LC 6	3GBP403530---K	1194	95,8	95,6	94,9	0,84	777	8,1	4000	2,6	3,0	22	3300	79	
500	M3BP 400LKC 6	3GBP403830---K	1194	95,8	95,6	94,9	0,84	777	8,1	4000	2,6	3,0	22	3300	79	
560	M3BP 400LD 6	3GBP403540---K	1194	95,8	95,6	94,8	0,85	856	7,8	4481	2,4	3,2	24	3400	79	
560	M3BP 400LKD 6	3GBP403840---K	1194	95,8	95,6	94,8	0,85	856	7,8	4481	2,4	3,2	24	3400	79	
630	M3BP 450LA 6	3GBP453510---K	1195	95,8	95,6	94,8	0,84	978	6,8	5036	1,1	2,9	31	4150	85	
710	M3BP 450LB 6	3GBP453520---K	1196	95,8	95,7	94,9	0,85	1085	8,2	5671	1,4	2,9	37	4500	85	
800	M3BP 450LC 6	3GBP453530---K	1195	95,8	98,4	94,7	0,84	1235	8,4	6389	1,3	3,1	41	4800	85	

Output kW	Motor type	Product code	Efficiency IEC 60034-30-1: 2014					Current		Torque			Moment of inertia J = 1/4 GD ₂ kgm ₂	Weight kg	Sound pressure Level L _{PA} dB
			Speed r/min	Full load 100%	3/4 load 75%	1/2 load 50%	Power factor Cos	I _n A	I _s /I _N	T _N Nm	T _i /T _N	T _b /T _N			
1200 r/min = 6 poles			460 V 60Hz					COMPACT-design							
18.5	M3BP 180MLB 6	3GBP183420-...K	1183	93,0	93,0	92,1	0,69	36,1	8,2	149	2,6	3,7	0,197	219	68
37	M3BP 225SMB 6	3GBP223220-...K	1189	94,1	94,1	93,2	0,75	65,5	8,8	297	3,6	3,7	0,799	382	71
45	M3BP 250SMB 6	3GBP253220-...K	1193	94,5	94,4	93,4	0,77	77,5	8,3	362	3,4	3,9	1,33	465	71
75	M3BP 280SMD 6	3GBP283240-...K	1192	95,0	95,0	94,3	0,83	119	8,7	601	3,0	3,3	3	740	76
90	M3BP 280MLA 6	3GBP283410-...K	1192	95,0	95,2	94,7	0,80	149	8,1	726	3,3	3,4	3,4	920	76
110	M3BP 280MLB 6	3GBP283420-...K	1190	95,8	96,0	95,7	0,80	182	7,7	887	3,2	3,2	3,4	920	67
160	M3BP 315LKC 6	3GBP313830-...K	1195	95,8	95,8	95,1	0,79	267	7,8	1279	2,3	3,2	6,8	1450	79
180	M3BP 315LKD 6	3GBP313840-...K	1195	95,8	95,8	94,9	0,79	296	9,0	1438	3,0	4,0	8,3	1520	79
200	M3BP 315LKE 6	3GBP313850-...K	1194	95,8	95,7	95,0	0,80	322	8,0	1599	2,5	3,1	9,2	1600	79

Technical data

IE3 cast iron motors 460 V 60 Hz

IP 55 - IC 411 - Insulation class F, temperature rise class B

IE3 efficiency class according to IEC 60034-30-1; 2014

Output kW	Motor type	Product code	Efficiency IEC 60034-30-1: 2014					Current			Torque			Moment of inertia J = 1/4 GD ₂ kgm ₂	Weight kg	Sound pressure Level L _{PA} dB	
			Speed r/min	Full load 100%	>3/4 load 75%	1/2 load 50%	Power factor Cos	I _n A	I _s /I _N	T _N Nm	T _i /T _N	T _b /T _N					
800 r/min = 8 poles			460 V 60Hz					BASIC-design									
0.37	M3BP 90SLF 8	3GBP094060---K	866	72,0	69,6	63,7	0,50	1,30	3,7	4,1	2,5	3,9	0,0056	28	53		
0.55	M3BP 90LG 8	3GBP094570---K	866	74,0	72,2	67,0	0,49	1,80	4,6	6,3	2,7	3,8	0,0072	32	56		
0.75	M3BP 100LKA 8	3GBP104810---K	866	75,6	74,0	68,6	0,61	1,93	4,9	8,3	2,6	3,2	0,00855	37	57		
1.5	M3BP 112MC 8	3GBP114330---K	872	84,0	83,6	81,3	0,58	3,7	4,7	16,4	1,9	3,0	0,0194	53	59		
2.2	M3BP 132SMA 8	3GBP134210---K	879	85,5	84,9	82,2	0,60	5,2	5,7	23,9	2,1	3,4	0,0291	66	61		
3	M3BP 132SMG 8	3GBP134270---K	877	86,5	86,3	84,1	0,63	6,7	5,4	32,6	1,9	3,2	0,0375	76	61		
4	M3BP 160MLA 8	3GBP164410---K	886	86,5	86,1	83,5	0,63	9,19	5,0	43,1	2,1	2,7	0,091	130	63		
5.5	M3BP 160MLB 8	3GBP164420---K	886	86,5	86,5	84,6	0,67	11,4	5,6	59,2	2,3	2,6	0,091	132	63		
7.5	M3BP 160MLC 8	3GBP164430---K	887	89,5	89,6	88,2	0,67	15,5	5,8	80,7	2,4	2,7	0,12	167	63		
11	M3BP 180MLA 8	3GBP184410---K	885	89,5	89,5	87,8	0,68	22,2	5,7	119	2,3	2,4	0,2	219	63		
15	M3BP 200MLA 8	3GBP204410---K	889	90,2	90,5	89,5	0,72	28,6	6,0	161	2,4	2,9	0,45	290	64		
18.5	M3BP 225SMA 8	3GBP224210---K	890	90,2	90,3	89,0	0,72	35,1	5,9	198	2,2	2,5	0,669	350	67		
22	M3BP 225SMB 8	3GBP224220---K	889	91,7	92,2	91,6	0,71	41,7	6,0	236	2,6	2,8	0,722	363	67		
30	M3BP 250SMA 8	3GBP254210---K	892	91,7	91,8	90,5	0,68	59,4	6,3	321	2,7	3,0	1,4	440	67		
37	M3BP 280SMA 8	3GBP284210---K	893	92,4	92,1	90,5	0,78	64,2	8,1	396	1,8	3,4	1,85	605	68		
45	M3BP 280SMB 8	3GBP284220---K	892	92,4	92,1	90,5	0,77	78,8	8,5	482	1,9	3,5	2,2	645	69		
55	M3BP 315SMA 8	3GBP314210---K	893	93,6	93,3	92,0	0,80	92,8	8,0	589	1,9	3,0	3,2	830	65		
75	M3BP 315SMB 8	3GBP314220---K	892	93,6	93,6	92,6	0,81	129	7,9	803	1,8	3,0	4,1	930	65		
90	M3BP 315SMC 8	3GBP314230---K	890	94,1	94,1	93,1	0,81	149	8,3	964	1,9	3,0	4,9	1000	67		
110	M3BP 315MLA 8	3GBP314410---K	892	94,1	94,2	93,5	0,81	182	8,2	1178	1,9	3,0	5,8	1150	75		
132	M3BP 355SMA 8	3GBP354210---K	895	94,5	94,2	92,9	0,76	230	8,3	1409	1,5	2,9	7,9	1520	72		
160	M3BP 355SMB 8	3GBP354220---K	895	94,5	94,3	93,0	0,78	274	8,4	1703	1,6	2,8	9,7	1680	72		
200	M3BP 355SMC 8	3GBP354230---K	893	95,0	94,9	94,0	0,79	335	8,2	2143	1,7	2,9	11,3	1820	72		
250	M3BP 355MLB 8	3GBP354420---K	893	95,0	94,9	94,0	0,79	417	8,3	2672	1,6	2,9	13,5	2180	75		
315	M3BP 400LA 8	3GBP404510---K	894	95,0	95,0	94,3	0,80	520	7,0	3362	1,2	2,9	17	2900	73		
315	M3BP 400LKA 8	3GBP404810---K	894	95,0	95,0	94,3	0,80	520	7,0	3362	1,2	2,9	17	2900	73		
315	M3BP 355LKB 8	3GBP354820---K	893	95,0	95,0	94,1	0,79	524	8,8	3369	1,8	2,9	16,5	2600	78		
355	M3BP 400LB 8	3GBP404520---K	894	95,0	95,1	94,5	0,82	564	8,4	3793	1,2	2,8	21	3200	73		
355	M3BP 400LKB 8	3GBP404820---K	894	95,0	95,1	94,5	0,82	564	8,4	3793	1,2	2,8	21	3200	73		
400	M3BP 400LC 8	3GBP404530---K	895	95,0	95,1	94,2	0,81	647	6,4	4273	1,3	3,0	24	3400	73		
400	M3BP 400LKC 8	3GBP404830---K	895	95,0	95,1	94,2	0,81	647	6,4	4273	1,3	3,0	24	3400	73		
450	M3BP 450LA 8	3GBP454510---K	895	95,0	95,1	94,6	0,82	709	6,9	4803	1,1	2,7	26	3750	80		
500	M3BP 450LB 8	3GBP454520---K	895	95,0	95,0	94,4	0,82	787	7,3	5336	1,1	2,8	29	4000	80		
560	M3BP 450LC 8	3GBP454530---K	894	95,0	95,0	94,2	0,81	907	6,5	5979	1,4	3,1	35	4350	80		
630	M3BP 450LD 8	3GBP454540---K	896	95,0	94,8	93,7	0,81	1013	8,6	6717	1,5	3,4	41	4800	80		

Output kW	Motor type	Product code	Efficiency IEC 60034-30-1: 2014					Current			Torque			Moment of inertia J = 1/4 GD ₂ kgm ₂	Weight kg	Sound pressure Level L _{PA} dB	
			Speed r/min	Full load 100%	3/4 load 75%	1/2 load 50%	Power factor Cos	I _n A	I _s /I _N	T _N Nm	T _i /T _N	T _b /T _N					
800 r/min = 8 poles			460 V 60Hz					COMPACT-design									
55	M3BP 280SMC 8	3GBP284230---K	891	93,6	93,6	92,6	0,76	95,2	9,0	588	2,4	3,7	2,85	725	69		
75	M3BP 280MLB 8	3GBP284420---K	889	93,6	94,1	93,9	0,78	129	6,7	809	2,0	3,4	4,1	890	75		
132	M3BP 315LKA 8	3GBP314810---K	895	94,5	94,5	93,8	0,77	231	8,2	1408	1,7	2,9	6,8	1470	78		
150	M3BP 315LKB 8	3GBP314820---K	895	94,5	94,5	93,6	0,76	262	8,5	1600	1,8	3,0	7,7	1560	78		
160	M3BP 315LKC 8	3GBP314830---K	895	94,5	94,8	94,4	0,77	276	8,7	1719	2,0	3,0	9,1	1610	78		

Technical data

IE4 cast iron motors 690 V 50 Hz

IP 55 - IC 411 - Insulation class F, temperature rise class B

IE3 efficiency class according to IEC 60034-30-1; 2014

Output kW	Motor type	Product code	Efficiency IEC 60034-30-1: 2014				Current			Torque			Moment of inertia J = 1/4 GD ₂ kgm ₂	Weight kg	Sound pressure Level L _{PA} dB
			Speed r/min	Full load 100%	>3/4 load 75%	1/2 load 50%	Power factor Cos	I _n A	I _s /I _N	T _N Nm	T _i /T _N	T _b /T _N			
1500 r/min = 4 poles			690 V 50Hz				CENELEC-design								
1100	M3BP 500LA 4	3GBP502510-M	1494	97,5	97,4	96,9	0,85	1110	7,0	7031	1,0	3,1	35,1	5900	86
1200	M3BP 500LB 4	3GBP502520-M	1495	97,6	97,4	96,9	0,83	1240	8,0	7665	1,2	3,6	39,4	6300	86
1300	M3BP 500LC 4	3GBP502530-M	1495	97,7	97,5	96,9	0,81	1375	8,8	8304	1,4	4,1	42,8	6600	86

Output kW	Motor type	Product code	Efficiency IEC 60034-30-1: 2014				Current			Torque			Moment of inertia J = 1/4 GD ₂ kgm ₂	Weight kg	Sound pressure Level L _{PA} dB
			Speed r/min	Full load 100%	>3/4 load 75%	1/2 load 50%	Power factor Cos	I _n A	I _s /I _N	T _N Nm	T _i /T _N	T _b /T _N			
1000 r/min = 6 poles			690 V 50Hz				CENELEC-design								
900	M3BP 500LA 6	3GBP503510-M	996	96,6	96,4	95,9	0,80	968	6,3	8629	1,3	3,6	50,8	5800	90
950	M3BP 500LB 6	3GBP503520-M	996	96,6	96,4	95,9	0,80	1020	6,7	9109	1,4	3,8	59,6	6200	90
1000	M3BP 500LC 6	3GBP503530-M	996	96,6	96,3	95,6	0,77	1116	8,0	9588	1,7	4,5	66,2	6600	90

Output kW	Motor type	Product code	Efficiency IEC 60034-30-1: 2014				Current			Torque			Moment of inertia J = 1/4 GD ₂ kgm ₂	Weight kg	Sound pressure Level L _{PA} dB
			Speed r/min	Full load 100%	>3/4 load 75%	1/2 load 50%	Power factor Cos	I _n A	I _s /I _N	T _N Nm	T _i /T _N	T _b /T _N			
750 r/min = 8 poles			690 V 50Hz				CENELEC-design								
700	M3BP 500LB 8	3GBP504520-M	746	95,4	95,4	94,7	0,77	784	6,0	8959	1,2	3,1	60,2	6200	84
750	M3BP 500LC 8	3GBP504530-M	746	95,4	95,4	94,6	0,76	850	6,6	9601	1,4	3,4	67	6600	84

Variant codes

IE5 cast iron motors

Variant codes specify additional options and features to the standard motor. The desired features are listed as three-digit variant codes in the motor order. Note also that there are variants that cannot be used together.

Code/Variants	Frame size					
	280	315	355	400	450	500
Administration						
100	Special design according to quotation (production orders).	-	-	-	-	-
247	Smoke extraction specification, 300°C, 2 hours, VSD use, Class F300(120)	-	-	-	-	-
529	Customer witnessed visual inspection of complete order line.	•	•	•	•	•
530	Two-year extension on standard warranty	•	•	•	•	•
531	Sea freight packing	•	•	•	•	•
532	Packing of motor in vertical mounting position	-	-	-	-	-
533	Wooden sea freight packing	•	•	•	-	-
590	Mounting of customer supplied part other than coupling.	•	•	•	•	•
648	Rating plate in special language	•	•	•	•	•
683	Prepared for ABB Ability Smart Sensor	•	•	•	•	•
684	ABB Ability Smart sensor mounted	•	•	•	•	•
999	Case specific design requiring a quotation	•	•	•	•	•
Balancing						
417	Vibration acc. to Grade B (IEC 60034-14).	•	•	•	•	•
423	Balanced without key.	•	•	•	•	•
424	Full-key balancing	•	•	•	•	•
Bearings and Lubrication						
036	Transport lock for bearings.	•	•	•	•	•
037	Roller bearing at D-end.	•	•	•	•	•
039	Cold-resistant grease	•	•	•	•	•
040	Heat-resistant grease	•	•	•	•	•
041	Bearings regreasable via grease nipples.	○	○	○	○	○
043	SPM compatible nipples for vibration measurement	○	○	○	○	○
057	2RS bearings at both ends.	-	-	-	-	-
058	Angular contact bearing at D-end, shaft force away from bearing.	•	•	•	•	-
059	Angular contact bearing at N-end, shaft force towards bearing.	•	•	•	•	-
060	Angular contact bearing at D-end, shaft force towards bearing.	•	•	•	•	-
061	Angular contact bearing at N-end, shaft force away from bearing.	•	•	•	•	-
107	Pt100 2-wire in bearings.	•	•	•	•	•
128	Double PT100, 2-wire in bearings	•	•	•	•	•
129	Double PT100, 3-wire in bearings	•	•	•	•	•
130	Pt100 3-wire in bearings.	•	•	•	•	•
188	63-series bearing in D-end	○	○	○	○	○
194	2Z bearings greased for life at both ends.	-	-	-	-	-
420	Bearing mounted PTC thermistors.	•	•	•	•	•
433	Outlet grease collector	•	•	•	•	•
506	Nipples for vibration measurement : SKF Marlin Quick Connect stud CMSS-2600-3	•	•	•	•	•
592	Pt1000 2-wire in stator winding, 1 per phase	•	•	•	•	•
593	Bearings grease suitable for food and beverage industry.	•	•	•	•	•
595	Pt1000 2-wire in stator winding, 2 per phase	•	•	•	•	•
596	Pt1000 3-wire in stator winding, 1 per phase	•	•	•	•	•
597	Pt1000 3-wire in stator winding, 2 per phase	•	•	•	•	•
654	Provision for vibration sensors (M8x1)	•	•	•	•	•
795	Lubrication information plate	○	○	○	○	○
796	Grease nipples JIS B 1575 PT 1/8 Type A	•	•	•	•	•
797	Stainless steel SPM nipples	•	•	•	•	•
798	Stainless steel grease nipples	•	•	•	•	•
799	Grease nipples flat type DIN 3404, thread M10x1	•	•	•	•	•
800	Grease nipples JIS B 1575 PT 1/8" pin type	•	•	•	•	•
Brakes						
517	KFB holding brake	•	•	•	-	-
518	SFB-SH holding brake	•	•	•	•	-

○ = Included as standard | • = Available as option | - = Not applicable

Code/Variants	Frame size					
	280	315	355	400	450	500
Branch standard designs						
142	Manilla connection.	-	-	-	-	-
172	Smoke extraction specification, 300 °C, 1 hour, DOL use, class F300 according to EN 12101-3	-	-	-	-	-
173	Smoke extraction specification, 200 °C, 2 hours, DOL use, class F200 according to EN 12101-3	-	-	-	-	-
174	Smoke extraction specification, 400 °C, 2 hours, DOL use, class F400 according to EN 12101-3	-	-	-	-	-
176	Smoke extraction specification, 300°C, 2 hours, DOL use, Class F300(120)	-	-	-	-	-
177	Design for high ambient applications	-	-	-	-	-
178	Stainless steel / acid proof bolts.	●	●	●	●	●
204	Jacking bolts for foot mounted motors.	●	●	○	○	○
209	Non-standard voltage or frequency, (special winding).	●	●	●	●	●
386	Smoke extraction specification, 200 °C, 2 hours, VSD use, Class F200 according to EN 12101-3.	-	-	-	-	-
387	Smoke extraction specification, 300 °C, 1 hour, VSD use, Class F300 according to EN 12101-3	-	-	-	-	-
389	Smoke extraction specification, 400 °C, 2 hours, VSD use, Class F400 according to EN 12101-3	-	-	-	-	-
392	Smoke extraction specification, 250 °C, 2 hours, DOL use, Class T250	-	-	-	-	-
393	Smoke extraction specification, 250 °C, 2 hours, VSD use, Class T250	-	-	-	-	-
396	Motor designed for minimum ambient temperature -20 °C to -40 °C, with space heaters (code 450/451 must be added)	●	●	●	●	●
397	Motor designed for minimum ambient temperature -40 °C to -55 °C, with space heaters (code 450/451 must be added)	●	●	●	●	●
398	Motor designed for minimum ambient temperature -20 °C to -40 °C	●	●	●	●	●
399	Motor designed for minimum ambient temperature -40 °C to -55 °C	●	●	●	●	●
425	Corrosion protected stator and rotor core.	●	●	●	●	●
524	Special run-out tolerances on flange and shaft for close coupled pump applications.	●	●	●	-	-
625	Design for mining applications.	●	●	●	●	-
786	Special design shaft upwards (V3, V35, V6) for outdoor mounting.	-	-	-	-	-
877	Design for high ambient applications, motor without fan and fan cover	-	-	-	-	-
Cooling system						
044	Unidirectional fan for reduced noise level. Rotation clockwise seen from D-end. Available only for 2-pole motors.	-	-	-	○	○
045	Unidirectional fan for reduced noise level. Rotation counter clockwise seen from D-end. Available only for 2-pole motors.	-	-	-	○	○
068	Light alloy metal fan	●	●	●	●	●
075	Cooling method IC418 (without fan).	●	●	●	●	-
183	Separate motor cooling (fan axial, N-end).	●	●	●	●	●
206	Steel fan	●	●	●	-	-
422	Separate motor cooling (on top) with integrated fan motor	●	●	●	●	-
514	Separate motor cooling (fan on top)	●	●	●	●	-
791	Stainless steel fan cover	●	●	●	●	●
Coupling						
035	Assembly of customer supplied coupling-half.	●	●	●	●	●
Documentation						
141	Binding 2D main dimension drawing.	●	●	●	●	●
370	Motor model drawing in 3D	●	●	●	●	●
374	Binding 2D motor detailed drawing	●	●	●	●	●
536	Photos of manufactured motors	●	●	●	●	●
537	Advanced data sheet	●	●	●	●	●
722	Rotor dimension drawing (incl. torsional stiffness).	●	●	●	●	●
777	Premium documentation package	●	●	●	●	●
Drain holes						
065	Plugged existing drain holes.	●	●	●	●	●
448	Draining holes with metal plugs.	●	●	●	●	●
Earthing Bolt						
067	External earthing bolt.	○	○	○	○	○
525	External earthing bolts on motor feet	●	●	●	●	●
Heating elements						
450	Heating element, 100-120 V	●	●	●	●	●
451	Heating element, 200 - 240 V	●	●	●	●	●
Insulation system						
014	Winding insulation class H.	●	●	●	●	●
405	Special winding insulation for frequency converter supply.	●	●	●	●	●
406	Winding insulation for supply > 690 <= 1000 volts	●	●	●	●	●

○ = Included as standard | ● = Available as option | - = Not applicable

Code/Variants	Frame size						
	280	315	355	400	450	500	
Marine							
024	Fulfilling Bureau Veritas (BV) requirements, with certificate.	•	•	•	•	•	•
025	Fulfilling DNV requirements, with certificate.	•	•	•	•	•	•
026	Fulfilling Lloyds Register of Shipping (LR) requirements, with certificate.	•	•	•	•	•	•
027	Fulfilling American Bureau of Shipping (ABS) requirements, with certificate.	•	•	•	•	•	•
050	Fulfilling Registro Italiano Navale (RINA) requirements, with certificate.	•	•	•	•	•	•
096	Fulfilling Lloyds Register of Shipping (LR) requirements, without certificate (non-essential duty only)	•	•	•	•	•	•
186	Fulfilling DNV requirements, without certificate	•	•	•	•	•	•
481	Fulfilling Nippon Kaiji Kyokai (NK) requirements, with certificate.	•	•	•	•	•	•
483	Fulfilling China Classification Societies (CCS) requirements (Beijing), with certificate.	•	•	•	•	•	•
484	Fulfilling Korea Register of Shipping (KR) requirements, with certificate.	•	•	•	•	•	•
491	Fulfilling Nippon Kaiji Kyokai (NK) requirements, without certificate.	•	•	•	•	•	•
492	Fulfilling Registro Italiano Navale (RINA) requirements, without certificate.	•	•	•	•	•	•
493	Fulfilling China Classification Societies (CCS) requirements (Beijing), without certificate.	•	•	•	•	•	•
494	Fulfilling Korea Register of Shipping (KR) requirements, without certificate.	•	•	•	•	•	•
496	Fulfilling Bureau Veritas (BV) requirements, without certificate(non-essential duty only)	•	•	•	•	•	•
675	Fulfilling American Bureau of Shipping (ABS) requirements, without certificate (non-essential duty only)	•	•	•	•	•	•
Mounting arrangements							
008	IM 2101 foot/flange mounted, IEC flange, from IM 1001 (B34 from B3).	-	-	-	-	-	-
009	IM 2001 foot/flange mounted, IEC flange, from IM 1001 (B35 from B3).	•	•	•	•	•	•
047	IM 3601 flange mounted, IEC flange, from IM 3001 (B14 from B5).	-	-	-	-	-	-
064	NEMA D-flange	-	-	-	-	-	-
066	Modified for specified mounting position differing from IM B3 (1001), IM B5 (3001), B14 (3601), IM B35 (2001), IM B34 (2101)	•	•	•	•	•	-
305	Additional lifting lugs.	•	•	•	•	•	•
320	IM2001 foot/flat bottom flange mounted, from IM1001 (B35 flat bottom flange from B3)	-	-	-	-	-	-
Noise reduction							
055	Noise reduction cover for foot mounted motor	•	•	•	•	•	-
Painting							
105	Paint thickness report.	•	•	•	•	•	•
114	Special paint color, standard grade	•	•	•	•	•	•
115	Painting system C4,durability Medium	•	•	•	•	•	•
168	Primer paint only.	•	•	•	•	•	•
303	Painted insulation layer on inside of the terminal boxes.	•	•	•	•	•	•
646	Special paint colour (China)	-	-	-	-	-	-
710	Norsok M-501 rev. 7 Coating system no. 2B	•	•	•	•	•	•
711	Painting system C5, durability High	•	•	•	•	•	•
712	Painting system C5-M according to Petrobras specification.	•	•	•	•	•	•
713	Painting system according Total Egina specification.	•	•	•	•	•	•
717	Painting system C4, durability High	•	•	•	•	•	•
719	Painting system CX	•	•	•	•	•	•
754	Painting system C5, durability Medium	•	•	•	•	•	•
755	Norsok M-501 revision 7, Coating system no. 1	•	•	•	•	•	•
Protection							
005	Protective roof	•	•	•	•	•	•
072	Radial seal at D-end. Not possible for 2-pole , 280 and 315 frames	-	-	-	-	-	-
073	Sealed against oil at D-end.	-	-	•	•	•	•
158	Degree of protection IP65.	•	•	•	•	•	-
211	Weather protected, IP xx W	-	-	-	-	-	-
250	Degree of protection IP66	•	•	•	•	•	-
401	Protective roof, horizontal motor.	•	•	•	•	•	-
403	Degree of protection IP56.	•	•	•	•	•	•
434	Degree of protection IP56, open deck.	•	•	•	•	•	-
520	Motor protection cover made of glass fiber. Vertical motor, shaft down.	•	•	•	•	-	-
783	Labyrinth sealing at D-end.	○	○	○	○	○	○
Rating & instruction plates							
002	Restamping voltage, frequency and output, continuous duty.	•	•	•	•	•	•
004	Additional text on std rating plate (max 12 digits on free text line).	•	•	•	•	•	•
095	Restamping output (maintained voltage, frequency), intermittent duty.	•	•	•	•	•	•
098	Stainless rating plate.	○	○	○	○	○	○
126	Tag plate	•	•	•	•	•	•
135	Mounting of additional identification plate, stainless.	•	•	•	•	•	•

○ = Included as standard | • = Available as option | - = Not applicable

Code/Variants	Frame size					
	280	315	355	400	450	500
138 Mounting of additional identification plate, aluminium.	-	-	-	-	-	-
139 Additional identification plate delivered loose.	•	•	•	•	•	•
159 Additional plate with text "Made in"	•	•	•	•	•	•
160 Additional rating plate affixed.	•	•	•	•	•	•
161 Additional rating plate delivered loose.	•	•	•	•	•	•
163 Frequency converter rating plate. Rating data according to quotation.	•	•	•	•	•	•
181 Rating plate with ABB standard loadability values for VSD operation. Other auxiliaries for VSD operation to be selected as necessary.	•	•	•	•	•	•
332 Baldor Catalogue #	-	-	-	-	-	-
333 Not for use in the USA	•	•	•	•	•	-
360 Kalmar rating plate	-	-	-	-	-	-
528 Rating plate sticker	•	•	•	•	•	•
818 Restamping as generator	•	•	•	•	•	•
Shaft & rotor						
069 Two shaft extensions according to catalog drawings.	•	•	•	•	•	-
070 Special shaft extension at D-End, standard shaft material	•	•	•	•	•	•
131 Motor delivered with half key (key not exceeding shaft diameter)	-	-	-	-	-	-
155 Cylindrical shaft extension, D-end, without key-way.	•	•	•	•	•	•
164 Shaft extension with closed keyway	•	•	•	•	-	-
165 Shaft extension with open keyway	○	○	○	○	○	○
410 Shaft material stainless steel	•	•	•	•	•	•
591 Special shaft extension according to customer specification.	•	•	•	•	•	•
600 Special shaft extension at N-end, standard shaft material.	•	•	•	•	•	•
630 Shaft material certificate 3.1/3.2 according to EN10204:2004	•	•	•	•	•	•
Standards and Regulations						
208 Fulfilling Underwriters Laboratories (UL), listed requirements	-	-	-	-	-	-
331 Motor not for sale for use in EU or UK.	•	•	•	•	•	•
421 VIK design (Verband der Industriellen Energie- und Kraftwirtschaft e.V.).	•	•	•	-	-	-
500 Fulfilling Korean MEPS efficiency regulations	-	-	-	-	-	-
509 Fulfilling US Integral Horsepower Motor Rule (IHP).	-	-	-	-	-	-
523 Neste Rotterdam design.	-	-	-	-	-	-
535 NBR IR3 design	-	-	-	-	-	-
540 Fulfilling energy efficiency requirements for China	-	-	-	•	•	-
543 Australian MEPS	-	-	-	-	-	-
544 Australian HE MEPS	-	-	-	-	-	-
546 SABS rating plate	-	-	-	-	-	-
552 BIS licence for India	-	-	-	-	-	-
558 Saudi Arabian MEPS (SASO)	•	•	•	-	-	-
564 Singapore MEPS	-	-	-	-	-	-
586 Fulfilling UK Conformity Assessment (UKCA) requirements.	•	•	•	•	•	•
598 Universal motor	-	-	-	-	-	-
758 Saudi Aramco design.	-	-	-	-	-	-
811 JIP-33 standard design	-	-	-	-	-	-
822 WIMES 3.03i6 Compliant Design for DOL operation	•	•	•	•	•	-
823 WIMES 3.03i6 Compliant Design for VSD operation	•	•	•	•	•	•
841 Shell DEP 33.66.05.31-GEN February 2022	•	•	•	-	-	-
Stator winding temperature sensors						
121 Bimetal detectors, break type (NCC), (3 in series), 130 °C, in stator winding	•	•	•	•	•	•
122 Bimetal detectors, break type (NCC), (3 in series), 150 °C, in stator winding	•	•	•	•	•	•
123 Bimetal detectors, break type (NCC), (3 in series), 170 °C, in stator winding	•	•	•	•	•	•
124 Bimetal detectors, break type (NCC), (3 in series), 140 °C, in stator winding	•	•	•	•	•	•
125 Bimetal detectors, break type (NCC), (2x3 in series), 150 °C, in stator winding	•	•	•	•	•	•
127 Bimetal detectors, break type (NCC), (3 in series, 130 °C & 3 in series, 150 °C), in stator winding	•	•	•	•	•	•
435 PTC - thermistors (3 in series), 130 °C, in stator winding	•	•	•	•	•	•
437 PTC - thermistors (3 in series), 170 °C, in stator winding	•	•	•	•	•	•
438 PTC - thermistors (3 in series), 190 °C, in stator winding	-	-	-	-	-	•
439 PTC - thermistors (2x3 in series), 150 °C, in stator winding	•	•	•	•	•	•
441 PTC - thermistors (3 in series, 130 °C & 3 in series, 150 °C), in stator winding	•	•	•	•	•	•
442 PTC - thermistors (3 in series, 150 °C & 3 in series, 170 °C), in stator winding	•	•	•	•	•	•
445 Pt100 2-wire in stator winding, 1 per phase	•	•	•	•	•	•
446 Pt100 2-wire in stator winding, 2 per phase	•	•	•	•	•	•
502 Pt100 3-wire in stator winding, 1 per phase	•	•	•	•	•	•
503 Pt100 3-wire in stator winding, 2 per phase	•	•	•	•	•	•
511 PTC thermistors (2 x 3 in series), 130 °C, in stator winding	•	•	•	•	•	•
515 Pt100 3-wire in stator winding, 3 per phase	•	•	•	•	•	•

○ = Included as standard | • = Available as option | - = Not applicable

Code/Variants	Frame size						
	280	315	355	400	450	500	
Terminal box							
019	Larger than standard terminal box.	●	●	●	●	-	-
020	Detached terminal box.	●	●	●	●	●	●
021	Terminal box LHS (seen from D-end).	●	●	●	●	-	-
022	Cable entry LHS (seen from D-end).	●	●	●	●	●	●
157	Terminal box degree of protection IP65.	●	●	●	●	-	-
180	Terminal box RHS (seen from D-end).	●	●	●	●	-	-
230	Standard metal cable gland.	●	●	●	-	-	-
277	Cable sealing end unit, size small for C-opening	●	-	-	-	-	-
278	Cable sealing end unit, size medium for D-opening	●	●	●	●	●	●
279	Cable sealing end unit, size large for D-opening	-	●	●	●	●	●
292	Adapter C-C	●	-	-	-	-	-
293	Adapter D-D	●	●	●	-	-	-
294	Adapter E-D	-	●	●	●	●	●
295	Adapter E-2D	-	●	●	○	○	○
296	Adapter E-3D	-	-	-	-	-	-
351	Terminal block turned according to cable entry	●	●	●	●	●	-
375	Standard plastic cable gland	-	-	-	-	-	-
380	Separate terminal box for temperature detectors, std. material	●	●	●	●	●	●
400	4 x 90 degr turnable terminal box.	○	○	○	-	-	-
413	Extended cable connection, no terminal box.	●	●	●	●	●	-
418	Separate terminal box for auxiliaries, standard material.	●	●	●	●	●	●
444	Adapter E-2E	-	-	-	-	-	-
447	Top mounted separate terminal box for monitoring equipment.	●	●	●	●	●	●
466	Terminal box at N-end.	●	●	●	●	●	-
467	Lower than standard terminal box and rubber extended cable. Cable length 2 m	-	-	-	-	-	-
468	Cable entry from D-end.	●	●	●	●	-	-
469	Cable entry from N-end.	●	●	●	●	-	-
553	Terminal box degree of protection IP66.	●	●	●	-	-	-
554	Cast iron flange for cable glands drilled and tapped according to order.	●	●	●	●	●	●
557	Nickel plated cable glands mounted according to order.	●	●	●	●	●	●
565	Adapter for terminal box on the side (RHS)	●	●	●	●	-	-
566	Adapter for terminal box on the side (LHS)	●	●	●	●	-	-
567	Separate terminal box material: cast Iron	●	●	●	●	●	●
568	Separate terminal box for heating elements, std. material	●	●	●	●	●	●
569	Separate terminal box for brakes	●	●	●	●	●	●
624	Prepared for inch cable glands according to BSPP standard.	●	●	●	●	●	-
727	Stainless steel flange for cable glands drilled and tapped according to order.	●	●	●	●	●	●
730	Prepared for NPT cable glands.	●	●	●	●	●	●
731	Two standard metal cable glands.	●	●	●	●	●	●
740	Prepared for PG cable glands.	-	-	-	-	-	-
742	Protective cover for accessory terminal block in main terminal box.	●	●	●	●	●	●
743	Non-drilled cast iron flange for cable glands	●	●	●	●	●	●
744	Stainless steel non-drilled flange for cable glands.	●	●	●	●	●	●
745	Painted cast iron flange equipped with nickel plated brass cable glands	●	●	●	●	●	●
746	Stainless steel cable flange equipped with standard nickel plated brass cable glands	●	●	●	●	●	●
Testing							
145	Type test report from a catalogue motor, 400V 50Hz.	●	●	●	●	●	-
146	Type test with report for one motor from specific delivery batch.	●	●	●	●	●	●
148	Routine test report.	●	●	●	●	●	●
149	Test according to separate test specification.	-	-	-	-	-	-
150	Customer witnessed testing. Specify test procedure with other codes.	●	●	●	●	●	●
222	Torque/speed test, type test and multi-point load test with report for one motor from specific delivery batch.	●	●	●	●	●	●
560	Shaft voltage test, for one motor from specific delivery batch.	●	●	●	●	●	●
561	Overspeed test, for one motor from specific delivery batch	●	●	●	●	●	●
562	Overvoltage test, for one motor from specific delivery batch.	●	●	●	●	●	●
760	Vibration level test	●	●	●	●	●	●
761	Vibration spectrum test for one motor from specific delivery batch.	●	●	●	●	●	●
762	Noise level test for one motor from specific delivery batch.	●	●	●	●	●	●
763	Noise spectrum test for one motor from specific delivery batch.	●	●	●	●	●	●
764	Test for one motor from specific delivery batch with ABB frequency converter available at ABB test field. ABB standard test procedure.	●	●	●	●	●	●

○ = Included as standard | ● = Available as option | - = Not applicable

Code/Variants	Frame size					
	280	315	355	400	450	500
Variable speed drives						
182	Mounting of non-listed pulse tacho.	•	•	•	•	•
429	Separate motor cooling (fan top, N-end) and 1024 pulse tacho (Leine & Linde 861) mounted.	•	•	•	•	•
470	Prepared for hollow shaft pulse tacho (L&L equivalent).	•	•	•	•	•
472	1024 pulse tacho (L&L 861007455-1024).	•	•	•	•	•
473	2048 pulse tacho (L&L 861007455-2048).	•	•	•	•	•
474	Separate motor cooling (axial fan, N-end) and prepared for hollow shaft tacho (L&L equivalent)	-	-	-	•	•
476	Separate motor cooling (axial fan, N-end) and 1024 pulse tacho (L&L 861007455-1024)	•	•	•	•	•
477	Separate motor cooling (axial fan, N-end) and 2048 pulse tacho (L&L 861007455-2048)	•	•	•	•	•
478	Separate motor cooling (fan on top, N-end) and prepared for hollow shaft tacho (L&L equivalent)	-	-	-	•	•
479	Mounting of other type of pulse tacho with shaft extension, tacho not included.	•	•	•	•	•
486	Separate motor cooling (fan top, N-end) and prepared for DC-tacho.	-	-	-	•	•
510	Separate motor cooling (fan top, N-end) and 2048 pulse tacho (Leine & Linde 861) mounted.	•	•	•	•	•
570	Prepared for hollow shaft pulse tacho (L&L 503).	-	-	-	-	-
588	Shaft grounding device	•	•	•	•	•
658	Special tacho mounted, price category 1	•	•	•	•	•
659	Special tacho mounted, price category 2	•	•	•	•	•
660	Special tacho mounted, price category 3	•	•	•	•	•
701	Insulated bearing at N-end.	•	•	•	•	•
702	Insulated bearings at both ends	-	-	-	-	-
704	EMC cable entry.	•	•	•	•	•
Y/D starting						
118	Terminals for Y/D start at high speed (two speed windings).	-	-	-	-	-
119	Terminals for Y/D start at low speed (two speed windings).	-	-	-	-	-

○ = Included as standard | • = Available as option | - = Not applicable

Variant codes

IE4 Cast iron motors

Variant codes specify additional options and features to the standard motor. The desired features are listed as three-digit variant codes in the motor order. Note also that there are variants that cannot be used together.

Code/Variants	Frame size													
	100	112	132	160	180	200	225	250	280	315	355	400	450	500
Administration														
100	Special design according to quotation (production orders).	•	•	•	•	•	•	•	•	•	•	•	•	•
247	Smoke extraction specification, 300°C, 2 hours, VSD use, Class F300(120)	-	-	-	•	•	•	•	•	•	•	•	•	-
529	Customer witnessed visual inspection of complete order line.	•	•	•	•	•	•	•	•	•	•	•	•	•
530	Two-year extension on standard warranty	•	•	•	•	•	•	•	•	•	•	•	•	•
531	Sea freight packing	•	•	•	•	•	•	•	•	•	•	•	•	•
532	Packing of motor in vertical mounting position	-	-	•	•	•	•	•	-	-	-	-	-	-
533	Wooden sea freight packing	-	-	-	-	-	-	-	•	•	•	-	-	-
590	Mounting of customer supplied part other than coupling.	-	-	-	•	•	•	•	•	•	•	•	•	•
648	Rating plate in special language	-	-	-	•	•	•	•	•	•	•	•	•	•
683	Prepared for ABB Ability Smart Sensor	-	-	-	•	•	•	•	•	•	•	•	•	•
684	ABB Ability Smart sensor mounted	-	-	-	•	•	•	•	•	•	•	•	•	•
999	Case specific design requiring a quotation	•	•	•	•	•	•	•	•	•	•	•	•	•
Balancing														
417	Vibration acc. to Grade B (IEC 60034-14).	•	•	•	•	•	•	•	•	•	•	•	•	•
423	Balanced without key.	•	•	•	•	•	•	•	•	•	•	•	•	•
424	Full-key balancing	•	•	•	•	•	•	•	•	•	•	•	•	•
Bearings and Lubrication														
036	Transport lock for bearings.	•	•	•	•	•	•	•	•	•	•	•	•	•
037	Roller bearing at D-end.	•	•	•	•	•	•	•	•	•	•	•	•	•
039	Cold-resistant grease	•	•	•	•	•	•	•	•	•	•	•	•	•
040	Heat-resistant grease	•	•	•	•	•	•	•	•	•	•	•	•	•
041	Bearings regreasable via grease nipples.	•	•	•	○	○	○	○	○	○	○	○	○	○
043	SPM compatible nipples for vibration measurement	•	•	•	○	○	○	○	○	○	○	○	○	○
057	2RS bearings at both ends.	•	•	•	•	•	•	•	-	-	-	-	-	-
058	Angular contact bearing at D-end, shaft force away from bearing.	-	-	-	•	•	•	•	•	•	•	•	•	-
059	Angular contact bearing at N-end, shaft force towards bearing.	-	-	-	-	-	-	-	•	•	•	•	•	-
060	Angular contact bearing at D-end, shaft force towards bearing.	-	-	-	-	-	-	-	•	•	•	•	•	-
061	Angular contact bearing at N-end, shaft force away from bearing.	-	-	-	-	-	-	-	•	•	•	•	•	-
107	Pt100 2-wire in bearings.	-	-	-	•	•	•	•	•	•	•	•	•	•
128	Double PT100, 2-wire in bearings	-	-	-	•	•	•	•	•	•	•	•	•	•
129	Double PT100, 3-wire in bearings	-	-	-	•	•	•	•	•	•	•	•	•	•
130	Pt100 3-wire in bearings.	-	-	-	•	•	•	•	•	•	•	•	•	•
188	63-series bearing in D-end	•	•	•	○	○	○	○	○	○	○	○	○	○
194	2Z bearings greased for life at both ends.	○	○	○	•	•	•	•	-	-	-	-	-	-
420	Bearing mounted PTC thermistors.	-	-	-	-	-	-	-	•	•	•	•	•	•
433	Outlet grease collector	-	-	-	-	-	-	-	•	•	•	•	•	•
506	Nipples for vibration measurement : SKF Marlin Quick Connect stud CMSS-2600-3	-	-	-	•	•	•	•	•	•	•	•	•	•
592	Pt1000 2-wire in stator winding, 1 per phase	•	•	•	•	•	•	•	•	•	•	•	•	•
593	Bearings grease suitable for food and beverage industry.	•	•	•	•	•	•	•	•	•	•	•	•	•
595	Pt1000 2-wire in stator winding, 2 per phase	-	-	-	•	•	•	•	•	•	•	•	•	•
596	Pt1000 3-wire in stator winding, 1 per phase	-	-	-	•	•	•	•	•	•	•	•	•	•
597	Pt1000 3-wire in stator winding, 2 per phase	-	-	-	•	•	•	•	•	•	•	•	•	•
654	Provision for vibration sensors (M8x1)	•	•	•	•	•	•	•	•	•	•	•	•	•
795	Lubrication information plate	-	-	-	•	•	•	•	○	○	○	○	○	○
796	Grease nipples JIS B 1575 PT 1/8 Type A	-	-	-	•	•	•	•	•	•	•	•	•	•
797	Stainless steel SPM nipples	•	•	•	•	•	•	•	•	•	•	•	•	•
798	Stainless steel grease nipples	-	-	-	•	•	•	•	•	•	•	•	•	•
799	Grease nipples flat type DIN 3404, thread M10x1	-	-	-	•	•	•	•	•	•	•	•	•	•
800	Grease nipples JIS B 1575 PT 1/8" pin type	-	-	-	•	•	•	•	•	•	•	•	•	•

○ = Included as standard | • = Available as option | - = Not applicable

Code/Variants	Frame size														
	100	112	132	160	180	200	225	250	280	315	355	400	450	500	
Brakes															
517	KFB holding brake	-	-	-	-	-	-	-	-	•	•	•	-	-	-
518	SFB-SH holding brake	-	-	-	-	-	-	-	-	•	•	•	•	-	-
Branch standard designs															
142	Manilla connection.	-	-	-	-	-	-	-	-	-	-	-	-	-	-
172	Smoke extraction specification, 300 °C, 1 hour, DOL use, class F300 according to EN 12101-3	-	-	-	•	•	•	•	•	•	•	•	•	•	-
173	Smoke extraction specification, 200 °C, 2 hours, DOL use, class F200 according to EN 12101-3	-	-	-	•	•	•	•	•	•	•	•	•	•	-
174	Smoke extraction specification, 400 °C, 2 hours, DOL use, class F400 according to EN 12101-3	-	-	-	•	•	•	•	•	•	•	•	•	•	-
176	Smoke extraction specification, 300°C, 2 hours, DOL use, Class F300(120)	-	-	-	•	•	•	•	•	•	•	•	•	•	-
177	Design for high ambient applications	-	-	-	-	-	-	-	-	-	-	-	-	-	-
178	Stainless steel / acid proof bolts.	•	•	•	•	•	•	•	•	•	•	•	•	•	•
204	Jacking bolts for foot mounted motors.	-	-	-	•	•	•	•	•	•	•	○	○	○	○
209	Non-standard voltage or frequency, (special winding).	•	•	•	•	•	•	•	•	•	•	•	•	•	•
386	Smoke extraction specification, 200 °C, 2 hours, VSD use, Class F200 according to EN 12101-3.	-	-	-	•	•	•	•	•	•	•	•	•	•	-
387	Smoke extraction specification, 300 °C, 1 hour, VSD use, Class F300 according to EN 12101-3	-	-	-	•	•	•	•	•	•	•	•	•	•	-
389	Smoke extraction specification, 400 °C, 2 hours, VSD use, Class F400 according to EN 12101-3	-	-	-	•	•	•	•	•	•	•	•	•	•	-
392	Smoke extraction specification, 250 °C, 2 hours, DOL use, Class T250	-	-	-	•	•	•	•	•	•	•	•	•	•	-
393	Smoke extraction specification, 250 °C, 2 hours, VSD use, Class T250	-	-	-	•	•	•	•	•	•	•	•	•	•	-
396	Motor designed for minimum ambient temperature -20 °C to -40 °C, with space heaters (code 450/451 must be added)	•	•	•	•	•	•	•	•	•	•	•	•	•	•
397	Motor designed for minimum ambient temperature -40 °C to -55 °C, with space heaters (code 450/451 must be added)	-	-	-	•	•	•	•	•	•	•	•	•	•	•
398	Motor designed for minimum ambient temperature -20 °C to -40 °C	•	•	•	•	•	•	•	•	•	•	•	•	•	•
399	Motor designed for minimum ambient temperature -40 °C to -55 °C	-	-	-	•	•	•	•	•	•	•	•	•	•	•
425	Corrosion protected stator and rotor core.	•	•	•	•	•	•	•	•	•	•	•	•	•	•
524	Special run-out tolerances on flange and shaft for close coupled pump applications.	-	-	-	-	-	-	-	-	•	•	-	-	-	-
625	Design for mining applications.	-	-	-	-	-	-	-	-	•	•	•	•	-	-
786	Special design shaft upwards (V3, V35, V6) for outdoor mounting.	•	•	•	•	•	•	•	•	•	•	-	-	-	-
877	Design for high ambient applications, motor without fan and fan cover	-	-	-	•	•	•	•	•	-	-	-	-	-	-
Cooling system															
044	Unidirectional fan for reduced noise level. Rotation clockwise seen from D-end. Available only for 2-pole motors.	-	-	-	-	-	-	-	-	-	-	-	•	•	-
045	Unidirectional fan for reduced noise level. Rotation counter clockwise seen from D-end. Available only for 2-pole motors.	-	-	-	-	-	-	-	-	-	-	-	•	•	-
068	Light alloy metal fan	•	•	•	•	•	•	•	•	•	•	•	•	•	•
075	Cooling method IC418 (without fan).	•	•	•	•	•	•	•	•	•	•	•	•	•	-
183	Separate motor cooling (fan axial, N-end).	•	•	•	•	•	•	•	•	•	•	•	•	•	•
206	Steel fan	•	•	•	•	•	•	•	•	•	•	•	•	-	-
422	Separate motor cooling (on top) with integrated fan motor	-	-	-	-	-	-	-	-	•	•	•	•	•	-
514	Separate motor cooling (fan on top)	-	-	-	-	-	-	-	-	-	-	-	•	•	-
791	Stainless steel fan cover	-	-	-	•	•	•	•	•	•	•	•	•	•	•
Coupling															
035	Assembly of customer supplied coupling-half.	-	-	-	-	-	-	-	-	•	•	•	•	•	•
Documentation															
141	Binding 2D main dimension drawing.	•	•	•	•	•	•	•	•	•	•	•	•	•	•
370	Motor model drawing in 3D	•	•	•	•	•	•	•	•	•	•	•	•	•	•
374	Binding 2D motor detailed drawing	•	•	•	•	•	•	•	•	•	•	•	•	•	•
536	Photos of manufactured motors	•	•	•	•	•	•	•	•	•	•	•	•	•	•
537	Advanced data sheet	•	•	•	•	•	•	•	•	•	•	•	•	•	•
722	Rotor dimension drawing (incl. torsional stiffness).	•	•	•	•	•	•	•	•	•	•	•	•	•	•
777	Premium documentation package	•	•	•	•	•	•	•	•	•	•	•	•	•	•
Drain holes															
065	Plugged existing drain holes.	•	•	•	•	•	•	•	•	•	•	•	•	•	•
448	Draining holes with metal plugs.	-	-	-	•	•	•	•	•	•	•	•	•	•	•
Earthing Bolt															
067	External earthing bolt.	•	•	•	○	○	○	○	○	○	○	○	○	○	○
525	External earthing bolts on motor feet	•	•	•	•	•	•	•	•	•	•	•	•	•	•

○ = Included as standard | • = Available as option | - = Not applicable

Code/Variants	Frame size													
	100	112	132	160	180	200	225	250	280	315	355	400	450	500
Heating elements														
450 Heating element, 100-120 V	•	•	•	•	•	•	•	•	•	•	•	•	•	•
451 Heating element, 200 - 240 V	•	•	•	•	•	•	•	•	•	•	•	•	•	•
Insulation system														
014 Winding insulation class H.	•	•	•	•	•	•	•	•	•	•	•	•	•	•
405 Special winding insulation for frequency converter supply.	•	•	•	•	•	•	•	•	•	•	•	•	•	•
406 Winding insulation for supply > 690 <= 1000 volts	-	-	-	-	-	-	-	-	•	•	•	•	•	•
Marine														
024 Fulfilling Bureau Veritas (BV) requirements, with certificate.	•	•	•	•	•	•	•	•	•	•	•	•	•	•
025 Fulfilling DNV requirements, with certificate.	•	•	•	•	•	•	•	•	•	•	•	•	•	•
026 Fulfilling Lloyds Register of Shipping (LR) requirements, with certificate.	•	•	•	•	•	•	•	•	•	•	•	•	•	•
027 Fulfilling American Bureau of Shipping (ABS) requirements, with certificate.	•	•	•	•	•	•	•	•	•	•	•	•	•	•
050 Fulfilling Registro Italiano Navale (RINA) requirements, with certificate.	•	•	•	•	•	•	•	•	•	•	•	•	•	•
096 Fulfilling Lloyds Register of Shipping (LR) requirements, without certificate (non-essential duty only)	•	•	•	•	•	•	•	•	•	•	•	•	•	•
186 Fulfilling DNV requirements, without certificate	•	•	•	•	•	•	•	•	•	•	•	•	•	•
481 Fulfilling Nippon Kaiji Kyokai (NK) requirements, with certificate.	•	•	•	•	•	•	•	•	•	•	•	•	•	•
483 Fulfilling China Classification Societies (CCS) requirements (Beijing), with certificate.	•	•	•	•	•	•	•	•	•	•	•	•	•	•
484 Fulfilling Korea Register of Shipping (KR) requirements, with certificate.	•	•	•	•	•	•	•	•	•	•	•	•	•	•
491 Fulfilling Nippon Kaiji Kyokai (NK) requirements, without certificate.	•	•	•	•	•	•	•	•	•	•	•	•	•	•
492 Fulfilling Registro Italiano Navale (RINA) requirements, without certificate.	•	•	•	•	•	•	•	•	•	•	•	•	•	•
493 Fulfilling China Classification Societies (CCS) requirements (Beijing), without certificate.	•	•	•	•	•	•	•	•	•	•	•	•	•	•
494 Fulfilling Korea Register of Shipping (KR) requirements, without certificate.	•	•	•	•	•	•	•	•	•	•	•	•	•	•
496 Fulfilling Bureau Veritas (BV) requirements, without certificate(non-essential duty only)	•	•	•	•	•	•	•	•	•	•	•	•	•	•
675 Fulfilling American Bureau of Shipping (ABS) requirements, without certificate (non-essential duty only)	•	•	•	•	•	•	•	•	•	•	•	•	•	•
Mounting arrangements														
008 IM 2101 foot/flange mounted, IEC flange, from IM 1001 (B34 from B3).	•	•	•	-	-	-	-	-	-	-	-	-	-	-
009 IM 2001 foot/flange mounted, IEC flange, from IM 1001 (B35 from B3).	•	•	•	•	•	•	•	•	•	•	•	•	•	•
047 IM 3601 flange mounted, IEC flange, from IM 3001 (B14 from B5).	•	•	•	-	-	-	-	-	-	-	-	-	-	-
064 NEMA D-flange	-	-	-	-	-	-	-	-	-	-	-	-	-	-
066 Modified for specified mounting position differing from IM B3 (1001), IM B5 (3001), B14 (3601), IM B35 (2001), IM B34 (2101)	•	•	•	•	•	•	•	•	•	•	•	•	•	-
305 Additional lifting lugs.	-	-	-	•	•	•	•	•	•	•	•	•	•	•
320 IM2001 foot/flat bottom flange mounted, from IM1001 (B35 flat bottom flange from B3)	-	-	-	-	-	-	-	-	-	-	-	-	-	-
Noise reduction														
055 Noise reduction cover for foot mounted motor	-	-	-	-	-	-	-	-	•	•	•	•	•	-
Painting														
105 Paint thickness report.	•	•	•	•	•	•	•	•	•	•	•	•	•	•
114 Special paint color, standard grade	•	•	•	•	•	•	•	•	•	•	•	•	•	•
115 Painting system C4,durability Medium	•	•	•	•	•	•	•	•	•	•	•	•	•	•
168 Primer paint only.	•	•	•	•	•	•	•	•	•	•	•	•	•	•
303 Painted insulation layer on inside of the terminal boxes.	•	•	•	•	•	•	•	•	•	•	•	•	•	•
646 Special paint colour (China)	•	•	•	•	•	•	•	•	•	•	•	•	•	-
710 Norsok M-501 rev. 7 Coating system no. 2B	•	•	•	•	•	•	•	•	•	•	•	•	•	•
711 Painting system C5, durability High	•	•	•	•	•	•	•	•	•	•	•	•	•	•
712 Painting system C5-M according to Petrobras specification.	•	•	•	-	-	-	-	-	•	•	•	•	•	•
713 Painting system according Total Egina specification.	-	-	-	•	•	•	•	•	•	•	•	•	•	•
717 Painting system C4, durability High	•	•	•	•	•	•	•	•	•	•	•	•	•	•
719 Painting system CX	•	•	•	•	•	•	•	•	•	•	•	•	•	•
754 Painting system C5, durability Medium	•	•	•	•	•	•	•	•	•	•	•	•	•	•
755 Norsok M-501 revision 7, Coating system no. 1	-	-	-	•	•	•	•	•	•	•	•	•	•	•
Protection														
005 Protective roof	•	•	•	•	•	•	•	•	•	•	•	•	•	•
072 Radial seal at D-end. Not possible for 2-pole , 280 and 315 frames	•	•	•	•	•	•	•	•	-	-	-	-	-	-
073 Sealed against oil at D-end.	-	-	-	•	•	•	•	•	-	-	-	•	•	•

○ = Included as standard | ● = Available as option | - = Not applicable

Code/Variants	Frame size													
	100	112	132	160	180	200	225	250	280	315	355	400	450	500
158 Degree of protection IP65.	•	•	•	•	•	•	•	•	•	•	•	•	•	-
211 Weather protected, IP xx W	•	•	•	•	•	•	•	•	-	-	-	-	-	-
250 Degree of protection IP66	•	•	•	•	•	•	•	•	•	•	•	•	•	-
401 Protective roof, horizontal motor.	-	-	-	-	-	-	-	-	•	•	•	•	•	-
403 Degree of protection IP56.	•	•	•	•	•	•	•	•	•	•	•	•	•	•
434 Degree of protection IP56, open deck.	-	-	-	-	-	-	-	-	•	•	•	•	•	-
520 Motor protection cover made of glass fiber. Vertical motor, shaft down.	-	-	-	-	-	-	-	-	•	•	•	•	-	-
783 Labyrinth sealing at D-end.	-	-	-	•	•	•	•	•	○	○	○	○	○	○
Rating & instruction plates														
138 Mounting of additional identification plate, aluminium.	-	-	-	-	-	-	-	-	-	-	-	-	-	-
139 Additional identification plate delivered loose.	•	•	•	•	•	•	•	•	•	•	•	•	•	•
159 Additional plate with text "Made in"	•	•	•	•	•	•	•	•	•	•	•	•	•	•
160 Additional rating plate affixed.	•	•	•	•	•	•	•	•	•	•	•	•	•	•
161 Additional rating plate delivered loose.	•	•	•	•	•	•	•	•	•	•	•	•	•	•
163 Frequency converter rating plate. Rating data according to quotation.	•	•	•	•	•	•	•	•	•	•	•	•	•	•
181 Rating plate with ABB standard loadability values for VSD operation. Other auxiliaries for VSD operation to be selected as necessary.	•	•	•	•	•	•	•	•	•	•	•	•	•	•
332 Baldor Catalogue #	-	-	-	•	•	•	•	•	•	•	•	-	-	-
333 Not for use in the USA	•	•	•	•	•	•	•	•	•	•	•	•	•	-
360 Kalmar rating plate	-	-	-	•	•	•	•	•	•	•	•	•	•	-
528 Rating plate sticker	•	•	•	-	-	-	-	-	•	•	•	•	•	•
818 Restamping as generator	•	•	•	•	•	•	•	•	•	•	•	•	•	•
002 Restamping voltage, frequency and output, continuous duty.	•	•	•	•	•	•	•	•	•	•	•	•	•	•
004 Additional text on std rating plate (max 12 digits on free text line).	•	•	•	•	•	•	•	•	•	•	•	•	•	•
095 Restamping output (maintained voltage, frequency), intermittent duty.	•	•	•	•	•	•	•	•	•	•	•	•	•	•
098 Stainless rating plate.	○	○	○	○	○	○	○	○	○	○	○	-	-	-
126 Tag plate	•	•	•	•	•	•	•	•	•	•	•	•	•	•
135 Mounting of additional identification plate, stainless.	•	•	•	•	•	•	•	•	•	•	•	•	•	•
Shaft & rotor														
069 Two shaft extensions according to catalog drawings.	•	•	•	•	•	•	•	•	•	•	•	•	•	-
070 Special shaft extension at D-End, standard shaft material	•	•	•	•	•	•	•	•	•	•	•	•	•	•
131 Motor delivered with half key (key not exceeding shaft diameter)	•	•	•	•	•	•	•	•	-	-	-	-	-	-
155 Cylindrical shaft extension, D-end, without key-way.	•	•	•	•	•	•	•	•	•	•	•	•	•	•
164 Shaft extension with closed keyway	○	○	○	○	○	○	○	○	•	•	•	•	-	-
165 Shaft extension with open keyway	-	-	-	•	•	•	•	•	○	○	○	○	○	○
410 Shaft material stainless steel	•	•	•	•	•	•	•	•	•	•	•	•	•	•
591 Special shaft extension according to customer specification.	•	•	•	•	•	•	•	•	•	•	•	•	•	•
600 Special shaft extension at N-end, standard shaft material.	•	•	•	•	•	•	•	•	•	•	•	•	•	•
630 Shaft material certificate 3.1/3.2 according to EN10204:2004	-	-	-	•	•	•	•	•	•	•	•	•	•	•
Standards and Regulations														
208 Fulfilling Underwriters Laboratories (UL), listed requirements	•	•	•	•	•	•	•	•	•	•	•	•	•	•
331 Motor not for sale for use in EU or UK.	•	•	•	•	•	•	•	•	•	•	•	•	•	•
421 VIK design (Verband der Industriellen Energie- und Kraftwirtschaft e.V.).	•	•	•	•	•	•	•	•	•	•	•	•	-	-
500 Fulfilling Korean MEPS efficiency regulations	-	-	-	-	-	-	-	-	-	-	-	-	-	-
509 Fulfilling US Integral Horsepower Motor Rule (IHP).	•	•	•	•	•	•	•	•	•	•	•	-	-	-
523 Neste Rotterdam design.	-	-	-	-	-	-	-	-	-	-	-	-	-	-
535 NBR IR3 design	-	-	-	-	-	-	-	-	-	-	-	-	-	-
540 Fulfilling energy efficiency requirements for China	•	•	•	•	•	•	•	•	•	•	•	•	•	-
543 Australian MEPS	-	-	-	-	-	-	-	-	-	-	-	-	-	-
544 Australian HE MEPS	•	•	•	•	•	•	•	•	•	•	•	-	-	-
546 SABS rating plate	-	-	-	-	-	-	-	-	-	-	-	•	-	-
552 BIS licence for India	-	-	-	-	-	-	-	-	•	•	•	-	-	-
558 Saudi Arabian MEPS (SASO)	•	•	•	•	•	•	•	•	•	•	•	-	-	-
564 Singapore MEPS	-	-	-	•	•	•	•	•	•	•	•	-	-	-
586 Fulfilling UK Conformity Assessment (UKCA) requirements.	•	•	•	•	•	•	•	•	•	•	•	•	•	•
598 Universal motor	-	-	-	-	-	-	-	-	-	-	-	-	-	-
758 Saudi Aramco design.	•	•	•	•	•	•	•	•	•	•	•	-	-	-
811 JIP-33 standard design	•	•	•	•	•	•	•	•	•	•	•	•	•	•
822 WIMES 3.03i6 Compliant Design for DOL operation	•	•	•	•	•	•	•	•	•	•	•	•	•	-
823 WIMES 3.03i6 Compliant Design for VSD operation	•	•	•	•	•	•	•	•	•	•	•	•	•	•
841 Shell DEP 33.66.05.31-GEN February 2022	•	•	•	•	•	•	•	•	•	•	•	-	-	-

○ = Included as standard | • = Available as option | - = Not applicable

Code/Variants	Frame size													
	100	112	132	160	180	200	225	250	280	315	355	400	450	500
Stator winding temperature sensors														
121	Bimetal detectors, break type (NCC), (3 in series), 130 °C, in stator winding													
122	Bimetal detectors, break type (NCC), (3 in series), 150 °C, in stator winding													
123	Bimetal detectors, break type (NCC), (3 in series), 170 °C, in stator winding													
124	Bimetal detectors, break type (NCC), (3 in series), 140 °C, in stator winding													
125	Bimetal detectors, break type (NCC), (2x3 in series), 150 °C, in stator winding													
127	Bimetal detectors, break type (NCC), (3 in series, 130 °C & 3 in series, 150 °C), in stator winding													
435	PTC - thermistors (3 in series), 130 °C, in stator winding													
437	PTC - thermistors (3 in series), 170 °C, in stator winding													
438	PTC - thermistors (3 in series), 190 °C, in stator winding													
439	PTC - thermistors (2x3 in series), 150 °C, in stator winding													
441	PTC - thermistors (3 in series, 130 °C & 3 in series, 150 °C), in stator winding													
442	PTC - thermistors (3 in series, 150 °C & 3 in series, 170 °C), in stator winding													
445	Pt100 2-wire in stator winding, 1 per phase													
446	Pt100 2-wire in stator winding, 2 per phase													
502	Pt100 3-wire in stator winding, 1 per phase													
503	Pt100 3-wire in stator winding, 2 per phase													
511	PTC thermistors (2 x 3 in series), 130 °C, in stator winding													
515	Pt100 3-wire in stator winding, 3 per phase													
Terminal box														
019	Larger than standard terminal box.													
020	Detached terminal box.													
021	Terminal box LHS (seen from D-end).													
022	Cable entry LHS (seen from D-end).													
157	Terminal box degree of protection IP65.													
180	Terminal box RHS (seen from D-end).													
230	Standard metal cable gland.													
277	Cable sealing end unit, size small for C-opening													
278	Cable sealing end unit, size medium for D-opening													
279	Cable sealing end unit, size large for D-opening													
292	Adapter C-C													
293	Adapter D-D													
294	Adapter E-D													
295	Adapter E-2D													
296	Adapter E-3D													
351	Terminal block turned according to cable entry													
375	Standard plastic cable gland													
380	Separate terminal box for temperature detectors, std. material													
400	4 x 90 degr turnable terminal box.													
413	Extended cable connection, no terminal box.													
418	Separate terminal box for auxiliaries, standard material.													
444	Adapter E-2E													
447	Top mounted separate terminal box for monitoring equipment.													
466	Terminal box at N-end.													
467	Lower than standard terminal box and rubber extended cable. Cable length 2 m													
468	Cable entry from D-end.													
469	Cable entry from N-end.													
553	Terminal box degree of protection IP66.													
554	Cast iron flange for cable glands drilled and tapped according to order.													
557	Nickel plated cable glands mounted according to order.													
565	Adapter for terminal box on the side (RHS)													
566	Adapter for terminal box on the side (LHS)													
567	Separate terminal box material: cast Iron													
568	Separate terminal box for heating elements, std. material													
569	Separate terminal box for brakes													
624	Prepared for inch cable glands according to BSPP standard.													
727	Stainless steel flange for cable glands drilled and tapped according to order.													

○ = Included as standard | ● = Available as option | - = Not applicable

Code/Variants	Frame size													
	100	112	132	160	180	200	225	250	280	315	355	400	450	500
730 Prepared for NPT cable glands.	•	•	•	•	•	•	•	•	•	•	•	•	•	•
731 Two standard metal cable glands.	•	•	•	•	•	•	•	•	•	•	•	•	•	•
740 Prepared for PG cable glands.	-	-	-	•	•	•	•	•	-	-	-	-	-	-
742 Protective cover for accessory terminal block in main terminal box.	-	-	-	-	-	-	-	-	•	•	•	•	•	•
743 Non-drilled cast iron flange for cable glands	-	-	-	•	•	•	•	•	•	•	•	•	•	•
744 Stainless steel non-drilled flange for cable glands.	-	-	-	•	•	•	•	•	•	•	•	•	•	•
745 Painted cast iron flange equipped with nickel plated brass cable glands	-	-	-	•	•	•	•	•	•	•	•	•	•	•
746 Stainless steel cable flange equipped with standard nickel plated brass cable glands	-	-	-	•	•	•	•	•	•	•	•	•	•	•
Testing														
145 Type test report from a catalogue motor, 400V 50Hz.	•	•	•	•	•	•	•	•	•	•	•	•	•	-
146 Type test with report for one motor from specific delivery batch.	•	•	•	•	•	•	•	•	•	•	•	•	•	•
148 Routine test report.	•	•	•	•	•	•	•	•	•	•	•	•	•	•
149 Test according to separate test specification.	-	-	-	•	•	•	•	•	-	-	-	-	-	-
150 Customer witnessed testing. Specify test procedure with other codes.	•	•	•	•	•	•	•	•	•	•	•	•	•	•
222 Torque/speed test, type test and multi-point load test with report for one motor from specific delivery batch.	•	•	•	•	•	•	•	•	•	•	•	•	•	•
560 Shaft voltage test, for one motor from specific delivery batch.	•	•	•	•	•	•	•	•	•	•	•	•	•	•
561 Overspeed test, for one motor from specific delivery batch	•	•	•	•	•	•	•	•	•	•	•	•	•	•
562 Overvoltage test, for one motor from specific delivery batch.	•	•	•	•	•	•	•	•	•	•	•	•	•	•
760 Vibration level test	•	•	•	•	•	•	•	•	•	•	•	•	•	•
761 Vibration spectrum test for one motor from specific delivery batch.	-	-	-	•	•	•	•	•	•	•	•	•	•	•
762 Noise level test for one motor from specific delivery batch.	•	•	•	•	•	•	•	•	•	•	•	•	•	•
763 Noise spectrum test for one motor from specific delivery batch.	-	-	-	•	•	•	•	•	•	•	•	•	•	•
764 Test for one motor from specific delivery batch with ABB frequency converter available at ABB test field. ABB standard test procedure.	•	•	•	•	•	•	•	•	•	•	•	•	•	•
Variable speed drives														
182 Mounting of non-listed pulse tacho.	-	-	-	•	•	•	•	•	•	•	•	•	•	•
429 Separate motor cooling (fan top, N-end) and 1024 pulse tacho (Leine & Linde 861) mounted.	-	-	-	-	-	-	-	-	•	•	•	•	•	•
470 Prepared for hollow shaft pulse tacho (L&L equivalent).	-	-	-	•	•	•	•	•	•	•	•	•	•	•
472 1024 pulse tacho (L&L 861007455-1024).	-	•	•	•	•	•	•	•	•	•	•	•	•	•
473 2048 pulse tacho (L&L 861007455-2048).	-	•	•	•	•	•	•	•	•	•	•	•	•	•
474 Separate motor cooling (axial fan, N-end) and prepared for hollow shaft tacho (L&L equivalent)	-	-	-	•	•	•	•	•	•	•	•	•	•	•
476 Separate motor cooling (axial fan, N-end) and 1024 pulse tacho (L&L 861007455-1024)	-	-	-	•	•	•	•	•	•	•	•	•	•	•
477 Separate motor cooling (axial fan, N-end) and 2048 pulse tacho (L&L 861007455-2048)	-	-	-	•	•	•	•	•	•	•	•	•	•	•
478 Separate motor cooling (fan on top, N-end) and prepared for hollow shaft tacho (L&L equivalent)	-	-	-	-	-	-	-	-	-	-	-	•	•	•
479 Mounting of other type of pulse tacho with shaft extension, tacho not included.	-	-	-	-	-	-	-	-	•	•	•	•	•	•
486 Separate motor cooling (fan top, N-end) and prepared for DC-tacho.	-	-	-	-	-	-	-	-	-	-	-	•	•	•
510 Separate motor cooling (fan top, N-end) and 2048 pulse tacho (Leine & Linde 861) mounted.	-	-	-	-	-	-	-	-	-	-	-	•	•	•
570 Prepared for hollow shaft pulse tacho (L&L 503).	-	-	-	-	-	-	-	-	-	-	-	-	-	-
588 Shaft grounding device	-	-	•	•	•	•	•	•	•	•	•	•	•	•
658 Special tacho mounted, price category 1	-	-	-	•	•	•	•	•	•	•	•	•	•	•
659 Special tacho mounted, price category 2	-	-	-	•	•	•	•	•	•	•	•	•	•	•
660 Special tacho mounted, price category 3	-	-	-	•	•	•	•	•	•	•	•	•	•	•
701 Insulated bearing at N-end.	-	-	-	•	•	•	•	•	•	•	•	•	•	•
702 Insulated bearings at both ends	•	•	•	•	•	•	•	•	-	-	-	-	-	-
704 EMC cable entry.	•	•	•	•	•	•	•	•	•	•	•	•	•	•
Y/D starting														
118 Terminals for Y/D start at high speed (two speed windings).	-	-	-	-	-	-	-	-	-	-	-	-	-	-
119 Terminals for Y/D start at low speed (two speed windings).	-	-	-	-	-	-	-	-	-	-	-	-	-	-

○ = Included as standard | • = Available as option | - = Not applicable

Variant codes

IE3 Cast iron motors

Variant codes specify additional options and features to the standard motor. The desired features are listed as three-digit variant codes in the motor order. Note also that there are variants that cannot be used together.

Code/Variants	Frame size																
	71	80	90	100	112	132	160	180	200	225	250	280	315	355	400	450	
Administration																	
100	Special design according to quotation (production orders).	•	•	•	•	•	•	•	•	•	•	•	•	•	•	•	•
247	Smoke extraction specification, 300°C, 2 hours, VSD use, Class F300(120)	-	-	-	-	-	-	•	•	•	•	•	•	•	•	•	•
529	Customer witnessed visual inspection of complete order line.	•	•	•	•	•	•	•	•	•	•	•	•	•	•	•	•
530	Two-year extension on standard warranty	•	•	•	•	•	•	•	•	•	•	•	•	•	•	•	•
531	Sea freight packing	•	•	•	•	•	•	•	•	•	•	•	•	•	•	•	•
532	Packing of motor in vertical mounting position	-	-	-	-	-	•	•	•	•	•	-	-	-	-	-	-
533	Wooden sea freight packing	-	-	-	-	-	-	-	-	-	-	•	•	•	-	-	-
590	Mounting of customer supplied part other than coupling.	•	•	•	•	•	•	•	•	•	•	•	•	•	•	•	•
648	Rating plate in special language	•	•	•	•	•	•	•	•	•	•	•	•	•	•	•	•
683	Prepared for ABB Ability Smart Sensor	-	-	-	-	-	-	•	•	•	•	•	•	•	•	•	•
684	ABB Ability Smart sensor mounted	-	-	-	-	-	-	•	•	•	•	•	•	•	•	•	•
999	Case specific design requiring a quotation	•	•	•	•	•	•	•	•	•	•	•	•	•	•	•	•
Balancing																	
417	Vibration acc. to Grade B (IEC 60034-14).	•	•	•	•	•	•	•	•	•	•	•	•	•	•	•	•
423	Balanced without key.	•	•	•	•	•	•	•	•	•	•	•	•	•	•	•	•
424	Full-key balancing	•	•	•	•	•	•	•	•	•	•	•	•	•	•	•	•
Bearings and Lubrication																	
036	Transport lock for bearings.	•	•	•	•	•	•	•	•	•	•	•	•	•	•	•	•
037	Roller bearing at D-end.	•	•	•	•	•	•	•	•	•	•	•	•	•	•	•	•
039	Cold-resistant grease	•	•	•	•	•	•	•	•	•	•	•	•	•	•	•	•
040	Heat-resistant grease	•	•	•	•	•	•	•	•	•	•	•	•	•	•	•	•
041	Bearings regreasable via grease nipples.	•	•	•	•	•	•	○	○	○	○	○	○	○	○	○	○
043	SPM compatible nipples for vibration measurement	•	•	•	•	•	•	○	○	○	○	○	○	○	○	○	○
057	2RS bearings at both ends.	•	•	•	•	•	•	•	•	•	•	•	-	-	-	-	-
058	Angular contact bearing at D-end, shaft force away from bearing.	•	•	•	•	•	•	•	•	•	•	•	•	•	•	•	•
059	Angular contact bearing at N-end, shaft force towards bearing.	-	-	-	-	-	-	-	-	-	-	-	•	•	•	•	•
060	Angular contact bearing at D-end, shaft force towards bearing.	-	-	-	-	-	-	-	-	-	-	-	•	•	•	•	•
061	Angular contact bearing at N-end, shaft force away from bearing.	-	-	-	-	-	-	-	-	-	-	-	•	•	•	•	•
107	Pt100 2-wire in bearings.	-	-	-	-	-	-	•	•	•	•	•	•	•	•	•	•
128	Double PT100, 2-wire in bearings	-	-	-	-	-	-	•	•	•	•	•	•	•	•	•	•
129	Double PT100, 3-wire in bearings	-	-	-	-	-	-	•	•	•	•	•	•	•	•	•	•
130	Pt100 3-wire in bearings.	-	-	-	-	-	-	•	•	•	•	•	•	•	•	•	•
188	63-series bearing in D-end	•	•	•	•	•	•	○	○	○	○	○	○	○	○	○	○
194	2Z bearings greased for life at both ends.	○	○	○	○	○	○	•	•	•	•	•	-	-	-	-	-
420	Bearing mounted PTC thermistors.	-	-	-	-	-	-	-	-	-	-	-	•	•	•	•	•
433	Outlet grease collector	-	-	-	-	-	-	-	-	-	-	-	•	•	•	•	•
506	Nipples for vibration measurement : SKF Marlin Quick Connect stud CMSS-2600-3	-	-	-	-	-	-	•	•	•	•	•	•	•	•	•	•
592	Pt1000 2-wire in stator winding, 1 per phase	•	•	•	•	•	•	•	•	•	•	•	•	•	•	•	•
593	Bearings grease suitable for food and beverage industry.	•	•	•	•	•	•	•	•	•	•	•	•	•	•	•	•
595	Pt1000 2-wire in stator winding, 2 per phase	-	-	-	-	-	-	•	•	•	•	•	•	•	•	•	•
596	Pt1000 3-wire in stator winding, 1 per phase	-	-	-	-	-	-	•	•	•	•	•	•	•	•	•	•
597	Pt1000 3-wire in stator winding, 2 per phase	-	-	-	-	-	-	•	•	•	•	•	•	•	•	•	•
654	Provision for vibration sensors (M8x1)	•	•	•	•	•	•	•	•	•	•	•	•	•	•	•	•
795	Lubrication information plate	-	-	-	-	-	-	•	•	•	•	•	○	○	○	○	○

○ = Included as standard | • = Available as option | - = Not applicable

Code/Variants	Frame size															
	71	80	90	100	112	132	160	180	200	225	250	280	315	355	400	450
796 Grease nipples JIS B 1575 PT 1/8 Type A	-	-	-	-	-	-	•	•	•	•	•	•	•	•	•	•
797 Stainless steel SPM nipples	•	•	•	•	•	•	•	•	•	•	•	•	•	•	•	•
798 Stainless steel grease nipples	-	-	-	-	-	-	•	•	•	•	•	•	•	•	•	•
799 Grease nipples flat type DIN 3404, thread M10x1	-	-	-	-	-	-	•	•	•	•	•	•	•	•	•	•
800 Grease nipples JIS B 1575 PT 1/8" pin type	-	-	-	-	-	-	•	•	•	•	•	•	•	•	•	•
Brakes																
517 KFB holding brake	-	-	-	-	-	-	-	-	-	-	-	•	•	•	-	-
518 SFB-SH holding brake	-	-	-	-	-	-	-	-	-	-	-	•	•	•	•	-
Branch standard designs																
142 Manilla connection.	•	•	•	•	•	•	•	•	•	•	•	•	•	-	-	-
172 Smoke extraction specification, 300 °C, 1 hour, DOL use, class F300 according to EN 12101-3	-	-	-	-	-	-	•	•	•	•	•	•	•	•	•	•
173 Smoke extraction specification, 200 °C, 2 hours, DOL use, class F200 according to EN 12101-3	-	-	-	-	-	-	•	•	•	•	•	•	•	•	•	•
174 Smoke extraction specification, 400 °C, 2 hours, DOL use, class F400 according to EN 12101-3	-	-	-	-	-	-	•	•	•	•	•	•	•	•	•	•
176 Smoke extraction specification, 300°C, 2 hours, DOL use, Class F300(120)	-	-	-	-	-	-	•	•	•	•	•	•	•	•	•	•
177 Design for high ambient applications	-	-	-	-	-	-	•	•	•	•	•	-	-	-	-	-
178 Stainless steel / acid proof bolts.	•	•	•	•	•	•	•	•	•	•	•	•	•	•	•	•
204 Jacking bolts for foot mounted motors.	-	-	-	-	-	-	•	•	•	•	•	•	•	○	○	○
209 Non-standard voltage or frequency, (special winding).	•	•	•	•	•	•	•	•	•	•	•	•	•	•	•	•
386 Smoke extraction specification, 200 °C, 2 hours, VSD use, Class F200 according to EN 12101-3.	-	-	-	-	-	-	•	•	•	•	•	•	•	•	•	•
387 Smoke extraction specification, 300 °C, 1 hour, VSD use, Class F300 according to EN 12101-3	-	-	-	-	-	-	•	•	•	•	•	•	•	•	•	•
389 Smoke extraction specification, 400 °C, 2 hours, VSD use, Class F400 according to EN 12101-3	-	-	-	-	-	-	•	•	•	•	•	•	•	•	•	•
392 Smoke extraction specification, 250 °C, 2 hours, DOL use, Class T250	-	-	-	-	-	-	•	•	•	•	•	•	•	•	•	•
393 Smoke extraction specification, 250 °C, 2 hours, VSD use, Class T250	-	-	-	-	-	-	•	•	•	•	•	•	•	•	•	•
396 Motor designed for minimum ambient temperature -20 °C to -40 °C, with space heaters (code 450/451 must be added)	•	•	•	•	•	•	•	•	•	•	•	•	•	•	•	•
397 Motor designed for minimum ambient temperature -40 °C to -55 °C, with space heaters (code 450/451 must be added)	-	-	-	-	-	-	•	•	•	•	•	•	•	•	•	•
398 Motor designed for minimum ambient temperature -20 °C to -40 °C	•	•	•	•	•	•	•	•	•	•	•	•	•	•	•	•
399 Motor designed for minimum ambient temperature -40 °C to -55 °C	-	-	-	-	-	-	•	•	•	•	•	•	•	•	•	•
425 Corrosion protected stator and rotor core.	•	•	•	•	•	•	•	•	•	•	•	•	•	•	•	•
524 Special run-out tolerances on flange and shaft for close coupled pump applications.	-	-	-	-	-	-	-	-	-	-	-	•	•	•	-	-
625 Design for mining applications.	•	•	•	•	•	•	•	•	•	•	•	•	•	•	•	-
786 Special design shaft upwards (V3, V35, V6) for outdoor mounting.	-	•	•	•	•	•	•	•	•	•	•	•	•	-	-	-
877 Design for high ambient applications, motor without fan and fan cover	-	-	-	-	-	-	•	•	•	•	•	-	-	-	-	-
Cooling system																
044 Unidirectional fan for reduced noise level. Rotation clockwise seen from D-end. Available only for 2-pole motors.	-	-	-	-	-	-	-	-	-	-	-	-	-	-	•	•
045 Unidirectional fan for reduced noise level. Rotation counter clockwise seen from D-end. Available only for 2-pole motors.	-	-	-	-	-	-	-	-	-	-	-	-	-	-	•	•
068 Light alloy metal fan	•	•	•	•	•	•	•	•	•	•	•	•	•	•	•	•
075 Cooling method IC418 (without fan).	•	•	•	•	•	•	•	•	•	•	•	•	•	•	•	•
183 Separate motor cooling (fan axial, N-end).	•	•	•	•	•	•	•	•	•	•	•	•	•	•	•	•
206 Steel fan	•	•	•	•	•	•	•	•	•	•	•	•	•	•	•	-
422 Separate motor cooling (on top) with integrated fan motor	-	-	-	-	-	-	-	-	-	-	-	•	•	•	•	•
514 Separate motor cooling (fan on top)	-	-	-	-	-	-	-	-	-	-	-	•	•	•	•	•
791 Stainless steel fan cover	-	-	-	-	-	-	•	•	•	•	•	•	•	•	•	•
Coupling																
035 Assembly of customer supplied coupling-half.	-	-	-	-	-	-	-	-	-	-	-	•	•	•	•	•
Documentation																
141 Binding 2D main dimension drawing.	•	•	•	•	•	•	•	•	•	•	•	•	•	•	•	•
370 Motor model drawing in 3D	-	•	•	•	•	•	•	•	•	•	•	•	•	•	•	•
374 Binding 2D motor detailed drawing	•	•	•	•	•	•	•	•	•	•	•	•	•	•	•	•

○ = Included as standard | • = Available as option | - = Not applicable

Code/Variants	Frame size															
	71	80	90	100	112	132	160	180	200	225	250	280	315	355	400	450
536	•	•	•	•	•	•	•	•	•	•	•	•	•	•	•	•
537	•	•	•	•	•	•	•	•	•	•	•	•	•	•	•	•
722	•	•	•	•	•	•	•	•	•	•	•	•	•	•	•	•
777	•	•	•	•	•	•	•	•	•	•	•	•	•	•	•	•
Drain holes																
065	•	•	•	•	•	•	•	•	•	•	•	•	•	•	•	•
448	-	-	-	-	-	-	•	•	•	•	•	•	•	•	•	•
Earthing Bolt																
067	•	•	•	•	•	•	○	○	○	○	○	○	○	○	○	○
525	-	•	•	•	•	•	•	•	•	•	•	•	•	•	•	•
Heating elements																
450	•	•	•	•	•	•	•	•	•	•	•	•	•	•	•	•
451	•	•	•	•	•	•	•	•	•	•	•	•	•	•	•	•
Insulation system																
014	•	•	•	•	•	•	•	•	•	•	•	•	•	•	•	•
405	•	•	•	•	•	•	•	•	•	•	•	•	•	•	•	•
406	-	-	-	-	-	-	-	-	•	•	•	•	•	•	•	•
Marine																
024	•	•	•	•	•	•	•	•	•	•	•	•	•	•	•	•
025	•	•	•	•	•	•	•	•	•	•	•	•	•	•	•	•
026	•	•	•	•	•	•	•	•	•	•	•	•	•	•	•	•
027	•	•	•	•	•	•	•	•	•	•	•	•	•	•	•	•
050	•	•	•	•	•	•	•	•	•	•	•	•	•	•	•	•
096	•	•	•	•	•	•	•	•	•	•	•	•	•	•	•	•
186	•	•	•	•	•	•	•	•	•	•	•	•	•	•	•	•
481	•	•	•	•	•	•	•	•	•	•	•	•	•	•	•	•
483	•	•	•	•	•	•	•	•	•	•	•	•	•	•	•	•
484	•	•	•	•	•	•	•	•	•	•	•	•	•	•	•	•
491	•	•	•	•	•	•	•	•	•	•	•	•	•	•	•	•
492	•	•	•	•	•	•	•	•	•	•	•	•	•	•	•	•
493	•	•	•	•	•	•	•	•	•	•	•	•	•	•	•	•
494	•	•	•	•	•	•	•	•	•	•	•	•	•	•	•	•
496	•	•	•	•	•	•	•	•	•	•	•	•	•	•	•	•
675	•	•	•	•	•	•	•	•	•	•	•	•	•	•	•	•
Mounting arrangements																
008	•	•	•	•	•	•	-	-	-	-	-	-	-	-	-	-
009	•	•	•	•	•	•	•	•	•	•	•	•	•	•	•	•
047	•	•	•	•	•	•	-	-	-	-	-	-	-	-	-	-
064	-	-	-	-	-	-	-	-	-	-	-	-	-	-	-	-
066	•	•	•	•	•	•	•	•	•	•	•	•	•	•	•	•
305	-	-	-	-	-	-	•	•	•	•	•	•	•	•	•	•
320	•	•	•	•	•	•	-	-	-	-	-	-	-	-	-	-
Noise reduction																
055	-	-	-	-	-	-	-	-	-	-	-	-	•	•	•	•
Painting																
105	•	•	•	•	•	•	•	•	•	•	•	•	•	•	•	•
114	•	•	•	•	•	•	•	•	•	•	•	•	•	•	•	•
115	•	•	•	•	•	•	•	•	•	•	•	•	•	•	•	•
168	•	•	•	•	•	•	•	•	•	•	•	•	•	•	•	•
303	•	•	•	•	•	•	•	•	•	•	•	•	•	•	•	•

○ = Included as standard | • = Available as option | - = Not applicable

Code/Variants	Frame size																
	71	80	90	100	112	132	160	180	200	225	250	280	315	355	400	450	
646	Special paint colour (China)	•	•	•	•	•	•	•	•	•	•	•	•	•	•	•	•
710	Norsok M-501 rev. 7 Coating system no. 2B	•	•	•	•	•	•	•	•	•	•	•	•	•	•	•	•
711	Painting system C5, durability High	•	•	•	•	•	•	•	•	•	•	•	•	•	•	•	•
712	Painting system C5-M according to Petrobras specification.	•	•	•	•	•	-	-	-	-	-	•	•	•	•	•	•
713	Painting system according Total Egina specification.	-	-	-	-	-	-	•	•	•	•	•	•	•	•	•	•
717	Painting system C4, durability High	•	•	•	•	•	•	•	•	•	•	•	•	•	•	•	•
719	Painting system CX	•	•	•	•	•	•	•	•	•	•	•	•	•	•	•	•
754	Painting system C5, durability Medium	•	•	•	•	•	•	•	•	•	•	•	•	•	•	•	•
755	Norsok M-501 revision 7, Coating system no. 1	-	-	-	-	-	-	•	•	•	•	•	•	•	•	•	•
Protection																	
005	Protective roof	•	•	•	•	•	•	•	•	•	•	•	•	•	•	•	•
072	Radial seal at D-end. Not possible for 2-pole , 280 and 315 frames	•	•	•	•	•	•	•	•	•	•	•	-	-	-	-	-
073	Sealed against oil at D-end.	-	-	-	-	-	-	•	•	•	•	•	-	-	•	•	•
158	Degree of protection IP65.	•	•	•	•	•	•	•	•	•	•	•	•	•	•	•	•
211	Weather protected, IP xx W	•	•	•	•	•	•	•	•	•	•	•	-	-	-	-	-
250	Degree of protection IP66	•	•	•	•	•	•	•	•	•	•	•	•	•	•	•	•
401	Protective roof, horizontal motor.	-	-	-	-	-	-	-	-	-	-	-	•	•	•	•	•
403	Degree of protection IP56.	•	•	•	•	•	•	•	•	•	•	•	•	•	•	•	•
434	Degree of protection IP56, open deck.	-	-	-	-	-	-	-	-	-	-	-	•	•	•	•	•
520	Motor protection cover made of glass fiber. Vertical motor, shaft down.	-	-	-	-	-	-	-	-	-	-	-	•	•	•	•	-
783	Labyrinth sealing at D-end.	-	-	-	-	-	-	•	•	•	•	•	•	•	○	○	○
Rating & instruction plates																	
002	Restamping voltage, frequency and output, continuous duty.	•	•	•	•	•	•	•	•	•	•	•	•	•	•	•	•
004	Additional text on std rating plate (max 12 digits on free text line).	•	•	•	•	•	•	•	•	•	•	•	•	•	•	•	•
095	Restamping output (maintained voltage, frequency), intermittent duty.	•	•	•	•	•	•	•	•	•	•	•	•	•	•	•	•
098	Stainless rating plate.	○	○	○	○	○	○	○	○	○	○	○	○	○	○	-	-
126	Tag plate	•	•	•	•	•	•	•	•	•	•	•	•	•	•	•	•
135	Mounting of additional identification plate, stainless.	•	•	•	•	•	•	•	•	•	•	•	•	•	•	•	•
138	Mounting of additional identification plate, aluminium.	•	•	•	•	•	•	-	-	-	-	-	-	-	-	-	-
139	Additional identification plate delivered loose.	•	•	•	•	•	•	•	•	•	•	•	•	•	•	•	•
159	Additional plate with text "Made in"	•	•	•	•	•	•	•	•	•	•	•	•	•	•	•	•
160	Additional rating plate affixed.	•	•	•	•	•	•	•	•	•	•	•	•	•	•	•	•
161	Additional rating plate delivered loose.	•	•	•	•	•	•	•	•	•	•	•	•	•	•	•	•
163	Frequency converter rating plate. Rating data according to quotation.	•	•	•	•	•	•	•	•	•	•	•	•	•	•	•	•
181	Rating plate with ABB standard loadability values for VSD operation. Other auxiliaries for VSD operation to be selected as necessary.	•	•	•	•	•	•	•	•	•	•	•	•	•	•	•	•
332	Baldor Catalogue #	•	•	•	•	•	•	•	•	•	•	•	•	•	•	-	-
333	Not for use in the USA	•	•	•	•	•	•	•	•	•	•	•	•	•	•	-	-
360	Kalmar rating plate	-	-	-	-	-	-	•	•	•	•	•	•	•	•	•	•
528	Rating plate sticker	-	•	•	•	•	•	-	-	-	-	-	•	•	•	•	•
818	Restamping as generator	•	•	•	•	•	•	•	•	•	•	•	•	•	•	•	•
Shaft & rotor																	
069	Two shaft extensions according to catalog drawings.	•	•	•	•	•	•	•	•	•	•	•	•	•	•	•	•
070	Special shaft extension at D-End, standard shaft material	•	•	•	•	•	•	•	•	•	•	•	•	•	•	•	•
131	Motor delivered with half key (key not exceeding shaft diameter)	•	•	•	•	•	•	•	•	•	•	•	-	-	-	-	-
155	Cylindrical shaft extension, D-end, without key-way.	•	•	•	•	•	•	•	•	•	•	•	•	•	•	•	•
164	Shaft extension with closed keyway	○	○	○	○	○	○	○	○	○	○	○	•	•	•	•	-
165	Shaft extension with open keyway	-	-	-	-	-	-	•	•	•	•	•	○	○	○	○	○
410	Shaft material stainless steel	•	•	•	•	•	•	•	•	•	•	•	•	•	•	•	•
591	Special shaft extension according to customer specification.	-	•	•	•	•	•	•	•	•	•	•	•	•	•	•	•
600	Special shaft extension at N-end, standard shaft material.	•	•	•	•	•	•	•	•	•	•	•	•	•	•	•	•
630	Shaft material certificate 3.1/3.2 according to EN10204:2004	-	-	-	-	-	-	•	•	•	•	•	•	•	•	•	•
Standards and Regulations																	
208	Fulfilling Underwriters Laboratories (UL), listed requirements	•	•	•	•	•	•	•	•	•	•	•	•	•	•	•	•
331	Motor not for sale for use in EU or UK.	•	•	•	•	•	•	•	•	•	•	•	•	•	•	•	•
421	VIK design (Verband der Industriellen Energie- und Kraftwirtschaft e.V.).	•	•	•	•	•	•	•	•	•	•	•	•	•	•	•	-

○ = Included as standard | • = Available as option | - = Not applicable

Code/Variants	Frame size															
	71	80	90	100	112	132	160	180	200	225	250	280	315	355	400	450
500	Fulfilling Korean MEPS efficiency regulations	-	•	•	•	•	•	•	•	•	•	•	•	•	-	-
509	Fulfilling US Integral Horsepower Motor Rule (IHP).	-	•	•	•	•	•	•	•	•	•	•	•	•	-	-
523	Neste Rotterdam design.	-	•	•	•	•	•	•	•	•	•	•	•	•	-	-
535	NBR IR3 design	-	•	•	•	•	•	•	•	•	•	•	•	•	-	-
540	Fulfilling energy efficiency requirements for China	•	•	•	•	•	•	•	•	•	•	•	•	•	•	•
543	Australian MEPS	-	-	-	-	-	-	-	-	-	-	-	-	-	-	-
544	Australian HE MEPS	-	•	•	•	•	•	•	•	•	•	•	•	•	-	-
546	SABS rating plate	-	-	-	-	-	-	-	-	-	-	-	-	-	•	-
552	BIS licence for India	-	•	•	•	•	•	•	•	•	•	•	•	•	-	-
558	Saudi Arabian MEPS (SASO)	-	•	•	•	•	•	•	•	•	•	•	•	•	-	-
564	Singapore MEPS	-	•	•	•	•	•	•	•	•	•	•	•	•	-	-
586	Fulfilling UK Conformity Assessment (UKCA) requirements.	•	•	•	•	•	•	•	•	•	•	•	•	•	•	•
598	Universal motor	-	•	•	•	•	•	•	•	•	•	•	•	•	-	-
758	Saudi Aramco design.	-	•	•	•	•	•	•	•	•	•	•	•	•	-	-
811	JIP-33 standard design	-	•	•	•	•	•	•	•	•	•	•	•	•	•	•
822	WIMES 3.03i6 Compliant Design for DOL operation	•	•	•	•	•	•	•	•	•	•	•	•	•	•	•
823	WIMES 3.03i6 Compliant Design for VSD operation	•	•	•	•	•	•	•	•	•	•	•	•	•	•	•
841	Shell DEP 33.66.05.31-GEN February 2022	-	•	•	•	•	•	•	•	•	•	•	•	•	-	-
Stator winding temperature sensors																
121	Bimetal detectors, break type (NCC), (3 in series), 130 °C, in stator winding	•	•	•	•	•	•	•	•	•	•	•	•	•	•	•
122	Bimetal detectors, break type (NCC), (3 in series), 150 °C, in stator winding	•	•	•	•	•	•	•	•	•	•	•	•	•	•	•
123	Bimetal detectors, break type (NCC), (3 in series), 170 °C, in stator winding	•	•	•	•	•	•	•	•	•	•	•	•	•	•	•
124	Bimetal detectors, break type (NCC), (3 in series), 140 °C, in stator winding	-	-	-	-	-	-	•	•	•	•	•	•	•	•	•
125	Bimetal detectors, break type (NCC), (2x3 in series), 150 °C, in stator winding	-	-	-	-	-	-	•	•	•	•	•	•	•	•	•
127	Bimetal detectors, break type (NCC), (3 in series, 130 °C & 3 in series, 150 °C), in stator winding	•	•	•	•	•	•	•	•	•	•	•	•	•	•	•
435	PTC - thermistors (3 in series), 130 °C, in stator winding	•	•	•	•	•	•	•	•	•	•	•	•	•	•	•
437	PTC - thermistors (3 in series), 170 °C, in stator winding	•	•	•	•	•	•	•	•	•	•	•	•	•	•	•
438	PTC - thermistors (3 in series), 190 °C, in stator winding	-	-	-	-	-	-	-	-	-	-	-	-	-	-	-
439	PTC - thermistors (2x3 in series), 150 °C, in stator winding	•	•	•	•	•	•	•	•	•	•	•	•	•	•	•
441	PTC - thermistors (3 in series, 130 °C & 3 in series, 150 °C), in stator winding	•	•	•	•	•	•	•	•	•	•	•	•	•	•	•
442	PTC - thermistors (3 in series, 150 °C & 3 in series, 170 °C), in stator winding	•	•	•	•	•	•	•	•	•	•	•	•	•	•	•
445	Pt100 2-wire in stator winding, 1 per phase	•	•	•	•	•	•	•	•	•	•	•	•	•	•	•
446	Pt100 2-wire in stator winding, 2 per phase	-	-	-	-	-	-	•	•	•	•	•	•	•	•	•
502	Pt100 3-wire in stator winding, 1 per phase	-	-	-	-	-	-	•	•	•	•	•	•	•	•	•
503	Pt100 3-wire in stator winding, 2 per phase	-	-	-	-	-	-	•	•	•	•	•	•	•	•	•
511	PTC thermistors (2 x 3 in series), 130 °C, in stator winding	-	-	-	-	-	-	-	-	-	-	•	•	•	•	•
515	Pt100 3-wire in stator winding, 3 per phase	-	-	-	-	-	-	-	-	-	-	•	•	•	•	•
Terminal box																
019	Larger than standard terminal box.	•	•	•	•	•	•	-	-	-	-	-	•	•	•	•
020	Detached terminal box.	-	-	-	-	-	-	•	•	•	•	•	•	•	•	•
021	Terminal box LHS (seen from D-end).	•	•	•	•	•	•	•	•	•	•	•	•	•	•	-
022	Cable entry LHS (seen from D-end).	•	•	•	•	•	•	•	•	•	•	•	•	•	•	•
157	Terminal box degree of protection IP65.	-	-	-	-	-	-	•	•	•	•	•	•	•	•	-
180	Terminal box RHS (seen from D-end).	•	•	•	•	•	•	•	•	•	•	•	•	•	•	-
230	Standard metal cable gland.	•	•	•	•	•	•	•	•	•	•	•	•	•	-	-
277	Cable sealing end unit, size small for C-opening	-	-	-	-	-	-	-	-	-	-	•	-	-	-	-
278	Cable sealing end unit, size medium for D-opening	-	-	-	-	-	-	-	-	-	-	•	•	•	•	•
279	Cable sealing end unit, size large for D-opening	-	-	-	-	-	-	-	-	-	-	•	•	•	•	•
292	Adapter C-C	-	-	-	-	-	-	-	-	-	-	•	-	-	-	-
293	Adapter D-D	-	-	-	-	-	-	-	-	-	-	•	•	•	-	-
294	Adapter E-D	-	-	-	-	-	-	-	-	-	-	•	•	•	•	•
295	Adapter E-2D	-	-	-	-	-	-	-	-	-	-	•	•	•	○	○
296	Adapter E-3D	-	-	-	-	-	-	-	-	-	-	•	•	•	•	•
351	Terminal block turned according to cable entry	-	-	-	-	-	-	-	-	-	-	•	•	•	•	•
375	Standard plastic cable gland	•	•	•	•	•	•	•	•	•	•	•	-	-	-	-
380	Separate terminal box for temperature detectors, std. material	-	-	-	-	-	-	•	•	•	•	•	•	•	•	•
400	4 x 90 degr turnable terminal box.	•	•	•	•	•	•	○	○	○	○	○	○	○	-	-
413	Extended cable connection, no terminal box.	-	-	-	-	-	-	•	•	•	•	•	•	•	•	•

○ = Included as standard | • = Available as option | - = Not applicable

Code/Variants	Frame size																
	71	80	90	100	112	132	160	180	200	225	250	280	315	355	400	450	
418	Separate terminal box for auxiliaries, standard material.	•	•	•	•	•	•	•	•	•	•	•	•	•	•	•	•
444	Adapter E-2E	-	-	-	-	-	-	-	-	-	-	-	-	-	-	-	-
447	Top mounted separate terminal box for monitoring equipment.	-	-	-	-	-	-	-	-	-	-	-	•	•	•	•	•
466	Terminal box at N-end.	-	-	-	-	-	-	•	•	•	•	•	•	•	•	•	•
467	Lower than standard terminal box and rubber extended cable. Cable length 2 m	-	-	-	-	-	-	•	•	•	•	•	-	-	-	-	-
468	Cable entry from D-end.	•	•	•	•	•	•	•	•	•	•	•	•	•	•	•	-
469	Cable entry from N-end.	•	•	•	•	•	•	•	•	•	•	•	•	•	•	•	-
553	Terminal box degree of protection IP66.	-	•	•	•	•	•	•	•	•	•	•	•	•	•	-	-
554	Cast iron flange for cable glands drilled and tapped according to order.	-	-	-	-	-	-	•	•	•	•	•	•	•	•	•	•
557	Nickel plated cable glands mounted according to order.	-	•	•	•	•	•	•	•	•	•	•	•	•	•	•	•
565	Adapter for terminal box on the side (RHS)	-	-	-	-	-	-	-	-	-	•	•	•	•	•	•	-
566	Adapter for terminal box on the side (LHS)	-	-	-	-	-	-	-	-	-	•	•	•	•	•	•	-
567	Separate terminal box material: cast Iron	-	-	-	-	-	-	•	•	•	•	•	•	•	•	•	•
568	Separate terminal box for heating elements, std. material	-	-	-	-	-	-	•	•	•	•	•	•	•	•	•	•
569	Separate terminal box for brakes	-	-	-	-	-	-	•	•	•	•	•	•	•	•	•	•
624	Prepared for inch cable glands according to BSPP standard.	•	•	•	•	•	•	•	•	•	•	•	•	•	•	•	•
727	Stainless steel flange for cable glands drilled and tapped according to order.	-	-	-	-	-	-	•	•	•	•	•	•	•	•	•	•
730	Prepared for NPT cable glands.	•	•	•	•	•	•	•	•	•	•	•	•	•	•	•	•
731	Two standard metal cable glands.	•	•	•	•	•	•	•	•	•	•	•	•	•	•	•	•
740	Prepared for PG cable glands.	-	-	-	-	-	-	•	•	•	•	•	-	-	-	-	-
742	Protective cover for accessory terminal block in main terminal box.	-	-	-	-	-	-	-	-	-	-	-	•	•	•	•	•
743	Non-drilled cast iron flange for cable glands	-	-	-	-	-	-	•	•	•	•	•	•	•	•	•	•
744	Stainless steel non-drilled flange for cable glands.	-	-	-	-	-	-	•	•	•	•	•	•	•	•	•	•
745	Painted cast iron flange equipped with nickel plated brass cable glands	-	-	-	-	-	-	•	•	•	•	•	•	•	•	•	•
746	Stainless steel cable flange equipped with standard nickel plated brass cable glands	-	-	-	-	-	-	•	•	•	•	•	•	•	•	•	•
Testing																	
145	Type test report from a catalogue motor, 400V 50Hz.	•	•	•	•	•	•	•	•	•	•	•	•	•	•	•	•
146	Type test with report for one motor from specific delivery batch.	•	•	•	•	•	•	•	•	•	•	•	•	•	•	•	•
148	Routine test report.	•	•	•	•	•	•	•	•	•	•	•	•	•	•	•	•
149	Test according to separate test specification.	-	-	-	-	-	-	•	-	•	-	-	-	-	-	-	-
150	Customer witnessed testing. Specify test procedure with other codes.	•	•	•	•	•	•	•	•	•	•	•	•	•	•	•	•
222	Torque/speed test, type test and multi-point load test with report for one motor from specific delivery batch.	•	•	•	•	•	•	•	•	•	•	•	•	•	•	•	•
560	Shaft voltage test, for one motor from specific delivery batch.	•	•	•	•	•	•	•	•	•	•	•	•	•	•	•	•
561	Overspeed test, for one motor from specific delivery batch	•	•	•	•	•	•	•	•	•	•	•	•	•	•	•	•
562	Overvoltage test, for one motor from specific delivery batch.	•	•	•	•	•	•	•	•	•	•	•	•	•	•	•	•
760	Vibration level test	•	•	•	•	•	•	•	•	•	•	•	•	•	•	•	•
761	Vibration spectrum test for one motor from specific delivery batch.	-	-	-	-	-	-	•	•	•	•	•	•	•	•	•	•
762	Noise level test for one motor from specific delivery batch.	•	•	•	•	•	•	•	•	•	•	•	•	•	•	•	•
763	Noise spectrum test for one motor from specific delivery batch.	-	-	-	-	-	-	•	•	•	•	•	•	•	•	•	•
764	Test for one motor from specific delivery batch with ABB frequency converter available at ABB test field. ABB standard test procedure.	•	•	•	•	•	•	•	•	•	•	•	•	•	•	•	•
Variable speed drives																	
182	Mounting of non-listed pulse tachometer.	-	-	-	-	-	-	•	•	•	•	•	•	•	•	•	•
429	Separate motor cooling (fan top, N-end) and 1024 pulse tachometer (Leine & Linde 861) mounted.	-	-	-	-	-	-	-	-	-	-	-	•	•	•	•	•
470	Prepared for hollow shaft pulse tachometer (L&L equivalent).	-	-	-	-	-	-	•	•	•	•	•	•	•	•	•	•
472	1024 pulse tachometer (L&L 861007455-1024).	-	-	-	-	-	-	•	•	•	•	•	•	•	•	•	•
473	2048 pulse tachometer (L&L 861007455-2048).	-	-	-	-	-	-	•	•	•	•	•	•	•	•	•	•
474	Separate motor cooling (axial fan, N-end) and prepared for hollow shaft tachometer (L&L equivalent)	-	-	-	-	-	-	•	•	•	•	•	•	•	•	•	•
476	Separate motor cooling (axial fan, N-end) and 1024 pulse tachometer (L&L 861007455-1024)	-	-	-	-	-	-	•	•	•	•	•	•	•	•	•	•

○ = Included as standard | ● = Available as option | - = Not applicable

Code/Variants	Frame size															
	71	80	90	100	112	132	160	180	200	225	250	280	315	355	400	450
477 Separate motor cooling (axial fan, N-end) and 2048 pulse tacho (L&L 861007455-2048)	-	-	-	-	-	-	•	•	•	•	•	•	•	•	•	•
478 Separate motor cooling (fan on top, N-end) and prepared for hollow shaft tacho (L&L equivalent)	-	-	-	-	-	-	-	-	-	-	-	•	•	•	•	•
479 Mounting of other type of pulse tacho with shaft extension, tacho not included.	-	-	-	-	-	-	-	-	-	-	-	•	•	•	•	•
486 Separate motor cooling (fan top, N-end) and prepared for DC-tacho.	-	-	-	-	-	-	-	-	-	-	-	•	•	•	•	•
510 Separate motor cooling (fan top, N-end) and 2048 pulse tacho (Leine & Linde 861) mounted.	-	-	-	-	-	-	-	-	-	-	-	•	•	•	•	•
570 Prepared for hollow shaft pulse tacho (L&L 503).	-	•	•	•	•	•	-	-	-	-	-	-	-	-	-	-
588 Shaft grounding device	-	-	-	-	-	•	•	•	•	•	•	•	•	•	•	•
658 Special tacho mounted, price category 1	-	-	-	-	-	-	•	•	•	•	•	•	•	•	•	•
659 Special tacho mounted, price category 2	-	-	-	-	-	-	•	•	•	•	•	•	•	•	•	•
660 Special tacho mounted, price category 3	-	-	-	-	-	-	•	•	•	•	•	•	•	•	•	•
701 Insulated bearing at N-end.	-	-	-	-	-	-	•	•	•	•	•	•	•	•	•	•
702 Insulated bearings at both ends	•	•	•	•	•	•	•	•	•	•	•	-	-	-	-	-
704 EMC cable entry.	•	•	•	•	•	•	•	•	•	•	•	•	•	•	•	•
Y/D starting																
118 Terminals for Y/D start at high speed (two speed windings).	-	-	-	-	-	-	-	-	-	-	-	•	•	-	-	-
119 Terminals for Y/D start at low speed (two speed windings).	-	-	-	-	-	-	-	-	-	-	-	•	•	-	-	-

○ = Included as standard | • = Available as option | - = Not applicable

Variant codes

IE2 Cast iron motors

Variant codes specify additional options and features to the standard motor. The desired features are listed as three-digit variant codes in the motor order. Note also that there are variants that cannot be used together.

Code/Variants	Frame size															
	71	80	90	100	112	132	160	180	200	225	250	280	315	355	400	450
Administration																
100	Special design according to quotation (production orders).	•	•	•	•	•	•	•	•	•	•	•	•	•	•	•
247	Smoke extraction specification, 300°C, 2 hours, VSD use, Class F300(120)	-	-	-	-	-	-	•	•	•	•	•	•	•	•	•
529	Customer witnessed visual inspection of complete order line.	•	•	•	•	•	•	•	•	•	•	•	•	•	•	•
530	Two-year extension on standard warranty	•	•	•	•	•	•	•	•	•	•	•	•	•	•	•
531	Sea freight packing	•	•	•	•	•	•	•	•	•	•	•	•	•	•	•
532	Packing of motor in vertical mounting position	-	-	-	-	-	•	•	•	•	•	-	-	-	-	-
533	Wooden sea freight packing	-	-	-	-	-	-	-	-	-	-	-	•	•	•	•
590	Mounting of customer supplied part other than coupling.	-	•	•	•	•	•	•	•	•	•	•	•	•	•	•
648	Rating plate in special language	•	•	•	•	•	•	•	•	•	•	•	•	•	•	•
683	Prepared for ABB Ability Smart Sensor	-	-	-	-	-	-	•	•	•	•	•	•	•	•	•
684	ABB Ability Smart sensor mounted	-	-	-	-	-	-	•	•	•	•	•	•	•	•	•
999	Case specific design requiring a quotation	•	•	•	•	•	•	•	•	•	•	•	•	•	•	•
Balancing																
417	Vibration acc. to Grade B (IEC 60034-14).	•	•	•	•	•	•	•	•	•	•	•	•	•	•	-
423	Balanced without key.	•	•	•	•	•	•	•	•	•	•	•	•	•	•	•
424	Full-key balancing	•	•	•	•	•	•	•	•	•	•	•	•	•	•	•
Bearings and Lubrication																
036	Transport lock for bearings.	•	•	•	•	•	•	•	•	•	•	•	•	•	•	•
037	Roller bearing at D-end.	•	•	•	•	•	•	•	•	•	•	•	•	•	•	•
039	Cold-resistant grease	•	•	•	•	•	•	•	•	•	•	•	•	•	•	•
040	Heat-resistant grease	•	•	•	•	•	•	•	•	•	•	•	•	•	•	•
041	Bearings regreasable via grease nipples.	•	•	•	•	•	•	○	○	○	○	○	○	○	○	○
043	SPM compatible nipples for vibration measurement	•	•	•	•	•	•	○	○	○	○	○	○	○	○	○
057	2RS bearings at both ends.	•	•	•	•	•	•	•	•	•	•	-	-	-	-	-
058	Angular contact bearing at D-end, shaft force away from bearing.	•	•	•	•	•	•	•	•	•	•	•	•	•	•	•
059	Angular contact bearing at N-end, shaft force towards bearing.	-	-	-	-	-	-	-	-	-	-	•	•	•	•	•
060	Angular contact bearing at D-end, shaft force towards bearing.	-	-	-	-	-	-	-	-	-	-	•	•	•	•	•
061	Angular contact bearing at N-end, shaft force away from bearing.	-	-	-	-	-	-	-	-	-	-	•	•	•	•	•
107	Pt100 2-wire in bearings.	-	-	-	-	-	-	•	•	•	•	•	•	•	•	•
128	Double PT100, 2-wire in bearings	-	-	-	-	-	-	•	•	•	•	•	•	•	•	•
129	Double PT100, 3-wire in bearings	-	-	-	-	-	-	•	•	•	•	•	•	•	•	•
130	Pt100 3-wire in bearings.	-	-	-	-	-	-	•	•	•	•	•	•	•	•	•
188	63-series bearing in D-end	•	•	•	•	•	•	○	○	○	○	○	○	○	○	○
194	2Z bearings greased for life at both ends.	○	○	○	○	○	○	•	•	•	•	-	-	-	-	-
420	Bearing mounted PTC thermistors.	-	-	-	-	-	-	-	-	-	-	•	•	•	•	•
433	Outlet grease collector	-	-	-	-	-	-	-	-	-	-	•	•	•	•	•
506	Nipples for vibration measurement : SKF Marlin Quick Connect stud CMSS-2600-3	-	-	-	-	-	-	•	•	•	•	•	•	•	•	•
592	Pt1000 2-wire in stator winding, 1 per phase	•	•	•	•	•	•	•	•	•	•	•	•	•	•	•
593	Bearings grease suitable for food and beverage industry.	•	•	•	•	•	•	•	•	•	•	•	•	•	•	•
595	Pt1000 2-wire in stator winding, 2 per phase	-	-	-	-	-	-	•	•	•	•	•	•	•	•	•
596	Pt1000 3-wire in stator winding, 1 per phase	-	-	-	-	-	-	•	•	•	•	•	•	•	•	•
597	Pt1000 3-wire in stator winding, 2 per phase	-	-	-	-	-	-	•	•	•	•	•	•	•	•	•
654	Provision for vibration sensors (M8x1)	•	•	•	•	•	•	•	•	•	•	•	•	•	•	•
795	Lubrication information plate	-	-	-	-	-	-	•	•	•	•	○	○	○	○	○
796	Grease nipples JIS B 1575 PT 1/8 Type A	•	•	•	•	•	•	•	•	•	•	•	•	•	•	•

○ = Included as standard | • = Available as option | - = Not applicable

Code/Variants	Frame size																
	71	80	90	100	112	132	160	180	200	225	250	280	315	355	400	450	
797	Stainless steel SPM nipples	●	●	●	●	●	●	●	●	●	●	●	●	●	●	●	●
798	Stainless steel grease nipples	●	●	●	●	●	●	●	●	●	●	●	●	●	●	●	●
799	Grease nipples flat type DIN 3404, thread M10x1	●	●	●	●	●	●	●	●	●	●	●	●	●	●	●	●
800	Grease nipples JIS B 1575 PT 1/8" pin type	-	-	-	-	-	-	●	●	●	●	●	●	●	●	●	●
Brakes																	
517	KFB holding brake	-	-	-	-	-	-	-	-	-	-	-	●	●	●	-	-
518	SFB-SH holding brake	-	-	-	-	-	-	-	-	-	-	-	●	●	●	●	-
Branch standard designs																	
142	Manilla connection.	●	●	●	●	●	●	●	●	●	●	●	●	●	-	-	-
172	Smoke extraction specification, 300 °C, 1 hour, DOL use, class F300 according to EN 12101-3	-	-	-	-	-	-	-	●	●	●	●	●	●	●	●	●
173	Smoke extraction specification, 200 °C, 2 hours, DOL use, class F200 according to EN 12101-3	-	-	-	-	-	-	●	●	●	●	●	●	●	●	●	●
174	Smoke extraction specification, 400 °C, 2 hours, DOL use, class F400 according to EN 12101-3	-	-	-	-	-	-	●	●	●	●	●	●	●	●	●	●
176	Smoke extraction specification, 300°C, 2 hours, DOL use, Class F300(120)	-	-	-	-	-	-	●	●	●	●	●	●	●	●	●	●
177	Design for high ambient applications	-	-	-	-	-	-	●	●	●	●	●	-	-	-	-	-
178	Stainless steel / acid proof bolts.	●	●	●	●	●	●	●	●	●	●	●	●	●	●	●	●
204	Jacking bolts for foot mounted motors.	-	-	-	-	-	-	●	●	●	●	●	●	○	○	○	○
209	Non-standard voltage or frequency, (special winding).	●	●	●	●	●	●	●	●	●	●	●	●	●	●	●	●
386	Smoke extraction specification, 200 °C, 2 hours, VSD use, Class F200 according to EN 12101-3.	-	-	-	-	-	-	●	●	●	●	●	●	●	●	●	●
387	Smoke extraction specification, 300 °C, 1 hour, VSD use, Class F300 according to EN 12101-3	-	-	-	-	-	-	●	●	●	●	●	●	●	●	●	●
389	Smoke extraction specification, 400 °C, 2 hours, VSD use, Class F400 according to EN 12101-3	-	-	-	-	-	-	●	●	●	●	●	●	●	●	●	●
392	Smoke extraction specification, 250 °C, 2 hours, DOL use, Class T250	-	-	-	-	-	-	●	●	●	●	●	●	●	●	●	●
393	Smoke extraction specification, 250 °C, 2 hours, VSD use, Class T250	-	-	-	-	-	-	●	●	●	●	●	●	●	●	●	●
396	Motor designed for minimum ambient temperature -20 °C to -40 °C, with space heaters (code 450/451 must be added)	●	●	●	●	●	●	●	●	●	●	●	●	●	●	●	●
397	Motor designed for minimum ambient temperature -40 °C to -55 °C, with space heaters (code 450/451 must be added)	-	-	-	-	-	-	●	●	●	●	●	●	●	●	●	●
398	Motor designed for minimum ambient temperature -20 °C to -40 °C	●	●	●	●	●	●	●	●	●	●	●	●	●	●	●	●
399	Motor designed for minimum ambient temperature -40 °C to -55 °C	-	-	-	-	-	-	●	●	●	●	●	●	●	●	●	●
425	Corrosion protected stator and rotor core.	●	●	●	●	●	●	●	●	●	●	●	●	●	●	●	●
524	Special run-out tolerances on flange and shaft for close coupled pump applications.	-	-	-	-	-	-	-	-	-	-	-	●	●	●	-	-
625	Design for mining applications.	●	●	●	●	●	●	●	●	●	●	●	●	●	●	●	-
786	Special design shaft upwards (V3, V35, V6) for outdoor mounting.	-	●	●	●	●	●	●	●	●	●	●	-	-	-	-	-
877	Design for high ambient applications, motor without fan and fan cover	-	-	-	-	-	-	●	●	●	●	●	-	-	-	-	-
Cooling system																	
044	Unidirectional fan for reduced noise level. Rotation clockwise seen from D-end. Available only for 2-pole motors.	-	-	-	-	-	-	-	-	-	-	-	●	●	●	●	●
045	Unidirectional fan for reduced noise level. Rotation counter clockwise seen from D-end. Available only for 2-pole motors.	-	-	-	-	-	-	-	-	-	-	-	●	●	●	●	●
068	Light alloy metal fan	●	●	●	●	●	●	●	●	●	●	●	●	●	●	●	●
075	Cooling method IC418 (without fan).	●	●	●	●	●	●	●	●	●	●	●	●	●	●	●	●
183	Separate motor cooling (fan axial, N-end).	●	●	●	●	●	●	●	●	●	●	●	●	●	●	●	●
206	Steel fan	●	●	●	●	●	●	●	●	●	●	●	●	●	●	●	-
422	Separate motor cooling (on top) with integrated fan motor	-	-	-	-	-	-	-	-	-	-	-	●	●	●	●	●
514	Separate motor cooling (fan on top)	-	-	-	-	-	-	-	-	-	-	-	●	●	●	●	●
791	Stainless steel fan cover	-	-	-	-	-	-	●	●	●	●	●	●	●	●	●	●
Coupling																	
035	Assembly of customer supplied coupling-half.	-	-	-	-	-	-	-	-	-	-	-	●	●	●	●	●
Documentation																	
141	Binding 2D main dimension drawing.	●	●	●	●	●	●	●	●	●	●	●	●	●	●	●	●
370	Motor model drawing in 3D	●	●	●	●	●	●	●	●	●	●	●	●	●	●	●	●
374	Binding 2D motor detailed drawing	●	●	●	●	●	●	●	●	●	●	●	●	●	●	●	●
536	Photos of manufactured motors	●	●	●	●	●	●	●	●	●	●	●	●	●	●	●	●
537	Advanced data sheet	●	●	●	●	●	●	●	●	●	●	●	●	●	●	●	●
722	Rotor dimension drawing (incl. torsional stiffness).	●	●	●	●	●	●	●	●	●	●	●	●	●	●	●	●

○ = Included as standard | ● = Available as option | - = Not applicable

Code/Variants	Frame size															
	71	80	90	100	112	132	160	180	200	225	250	280	315	355	400	450
777 Premium documentation package	•	•	•	•	•	•	•	•	•	•	•	•	•	•	•	•
Drain holes																
065 Plugged existing drain holes.	•	•	•	•	•	•	•	•	•	•	•	•	•	•	•	•
448 Draining holes with metal plugs.	-	-	-	-	-	-	•	•	•	•	•	•	•	•	•	•
Earthing Bolt																
067 External earthing bolt.	•	•	•	•	•	•	○	○	○	○	○	○	○	○	○	○
525 External earthing bolts on motor feet	-	•	•	•	•	•	•	•	•	•	•	•	•	•	•	•
Heating elements																
450 Heating element, 100-120 V	•	•	•	•	•	•	•	•	•	•	•	•	•	•	•	•
451 Heating element, 200 - 240 V	•	•	•	•	•	•	•	•	•	•	•	•	•	•	•	•
Insulation system																
014 Winding insulation class H.	•	•	•	•	•	•	•	•	•	•	•	•	•	•	•	•
405 Special winding insulation for frequency converter supply.	•	•	•	•	•	•	•	•	•	•	•	•	•	•	•	•
406 Winding insulation for supply > 690 <= 1000 volts	-	-	-	-	-	-	-	-	•	•	•	•	•	•	•	•
Marine																
024 Fulfilling Bureau Veritas (BV) requirements, with certificate.	•	•	•	•	•	•	•	•	•	•	•	•	•	•	•	•
025 Fulfilling DNV requirements, with certificate.	•	•	•	•	•	•	•	•	•	•	•	•	•	•	•	•
026 Fulfilling Lloyds Register of Shipping (LR) requirements, with certificate.	•	•	•	•	•	•	•	•	•	•	•	•	•	•	•	•
027 Fulfilling American Bureau of Shipping (ABS) requirements, with certificate.	•	•	•	•	•	•	•	•	•	•	•	•	•	•	•	•
050 Fulfilling Registro Italiano Navale (RINA) requirements, with certificate.	•	•	•	•	•	•	•	•	•	•	•	•	•	•	•	•
096 Fulfilling Lloyds Register of Shipping (LR) requirements, without certificate (non-essential duty only)	•	•	•	•	•	•	•	•	•	•	•	•	•	•	•	•
186 Fulfilling DNV requirements, without certificate	•	•	•	•	•	•	•	•	•	•	•	•	•	•	•	•
481 Fulfilling Nippon Kaiji Kyokai (NK) requirements, with certificate.	•	•	•	•	•	•	•	•	•	•	•	•	•	•	•	•
483 Fulfilling China Classification Societies (CCS) requirements (Beijing), with certificate.	•	•	•	•	•	•	•	•	•	•	•	•	•	•	•	•
484 Fulfilling Korea Register of Shipping (KR) requirements, with certificate.	•	•	•	•	•	•	•	•	•	•	•	•	•	•	•	•
491 Fulfilling Nippon Kaiji Kyokai (NK) requirements, without certificate.	•	•	•	•	•	•	•	•	•	•	•	•	•	•	•	•
492 Fulfilling Registro Italiano Navale (RINA) requirements, without certificate.	•	•	•	•	•	•	•	•	•	•	•	•	•	•	•	•
493 Fulfilling China Classification Societies (CCS) requirements (Beijing), without certificate.	•	•	•	•	•	•	•	•	•	•	•	•	•	•	•	•
494 Fulfilling Korea Register of Shipping (KR) requirements, without certificate.	•	•	•	•	•	•	•	•	•	•	•	•	•	•	•	•
496 Fulfilling Bureau Veritas (BV) requirements, without certificate(non-essential duty only)	•	•	•	•	•	•	•	•	•	•	•	•	•	•	•	•
675 Fulfilling American Bureau of Shipping (ABS) requirements, without certificate (non-essential duty only)	•	•	•	•	•	•	•	•	•	•	•	•	•	•	•	•
Mounting arrangements																
008 IM 2101 foot/flange mounted, IEC flange, from IM 1001 (B34 from B3).	•	•	-	•	•	•	-	-	-	-	-	-	-	-	-	-
009 IM 2001 foot/flange mounted, IEC flange, from IM 1001 (B35 from B3).	•	•	•	•	•	•	•	•	•	•	•	•	•	•	•	•
047 IM 3601 flange mounted, IEC flange, from IM 3001 (B14 from B5).	•	•	•	•	•	•	-	-	-	-	-	-	-	-	-	-
064 NEMA D-flange	-	-	-	-	-	-	-	-	-	-	-	-	-	•	-	-
066 Modified for specified mounting position differing from IM B3 (1001), IM B5 (3001), B14 (3601), IM B35 (2001), IM B34 (2101)	•	•	•	•	•	•	•	•	•	•	•	•	•	•	•	•
305 Additional lifting lugs.	-	-	-	-	-	-	•	•	•	•	•	•	•	•	•	•
320 IM2001 foot/flat bottom flange mounted, from IM1001 (B35 flat bottom flange from B3)	•	•	•	•	•	•	•	-	-	-	-	-	-	-	-	-
Noise reduction																
055 Noise reduction cover for foot mounted motor	-	-	-	-	-	-	-	-	-	-	-	•	•	•	•	•
Painting																
105 Paint thickness report.	•	•	•	•	•	•	•	•	•	•	•	•	•	•	•	•
114 Special paint color, standard grade	•	•	•	•	•	•	•	•	•	•	•	•	•	•	•	•
115 Painting system C4,durability Medium	•	•	•	•	•	•	•	•	•	•	•	•	•	•	•	•
168 Primer paint only.	•	•	•	•	•	•	•	•	•	•	•	•	•	•	•	•
303 Painted insulation layer on inside of the terminal boxes.	•	•	•	•	•	•	•	•	•	•	•	•	•	•	•	•
646 Special paint colour (China)	•	•	•	•	•	•	•	•	•	•	•	•	•	•	•	•
710 Norsok M-501 rev. 7 Coating system no. 2B	•	•	•	•	•	•	•	•	•	•	•	•	•	•	•	•
711 Painting system C5, durability High	•	•	•	•	•	•	•	•	•	•	•	•	•	•	•	•
712 Painting system C5-M according to Petrobras specification.	•	•	•	•	•	•	•	•	•	•	•	•	•	•	•	•

○ = Included as standard | • = Available as option | - = Not applicable

Code/Variants	Frame size															
	71	80	90	100	112	132	160	180	200	225	250	280	315	355	400	450
713	Painting system according Total Egina specification.															
717	Painting system C4, durability High															
719	Painting system CX															
754	Painting system C5, durability Medium															
755	Norsok M-501 revision 7, Coating system no. 1															
Protection																
005	Protective roof															
072	Radial seal at D-end. Not possible for 2-pole , 280 and 315 frames															
073	Sealed against oil at D-end.															
158	Degree of protection IP65.															
211	Weather protected, IP xx W															
250	Degree of protection IP66															
401	Protective roof, horizontal motor.															
403	Degree of protection IP56.															
434	Degree of protection IP56, open deck.															
520	Motor protection cover made of glass fiber. Vertical motor, shaft down.															
783	Labyrinth sealing at D-end.															
Rating & instruction plates																
002	Restamping voltage, frequency and output, continuous duty.															
004	Additional text on std rating plate (max 12 digits on free text line).															
095	Restamping output (maintained voltage, frequency), intermittent duty.															
098	Stainless rating plate.															
126	Tag plate															
135	Mounting of additional identification plate, stainless.															
138	Mounting of additional identification plate, aluminium.															
139	Additional identification plate delivered loose.															
159	Additional plate with text "Made in"															
160	Additional rating plate affixed.															
161	Additional rating plate delivered loose.															
163	Frequency converter rating plate. Rating data according to quotation.															
181	Rating plate with ABB standard loadability values for VSD operation. Other auxiliaries for VSD operation to be selected as necessary.															
332	Baldor Catalogue #															
333	Not for use in the USA															
360	Kalmar rating plate															
528	Rating plate sticker															
818	Restamping as generator															
Shaft & rotor																
069	Two shaft extensions according to catalog drawings.															
070	Special shaft extension at D-End, standard shaft material															
131	Motor delivered with half key (key not exceeding shaft diameter)															
155	Cylindrical shaft extension, D-end, without key-way.															
164	Shaft extension with closed keyway															
165	Shaft extension with open keyway															
410	Shaft material stainless steel															
591	Special shaft extension according to customer specification.															
600	Special shaft extension at N-end, standard shaft material.															
630	Shaft material certificate 3.1/3.2 according to EN10204:2004															
Standards and Regulations																
208	Fulfilling Underwriters Laboratories (UL), listed requirements															
331	Motor not for sale for use in EU or UK.															
421	VIK design (Verband der Industriellen Energie- und Kraftwirtschaft e.V.).															
500	Fulfilling Korean MEPS efficiency regulations															
509	Fulfilling US Integral Horsepower Motor Rule (IHP).															
523	Neste Rotterdam design.															
535	NBR IR3 design															
540	Fulfilling energy efficiency requirements for China															

○ = Included as standard | ● = Available as option | - = Not applicable

Code/Variants	Frame size															
	71	80	90	100	112	132	160	180	200	225	250	280	315	355	400	450
543	Australian MEPS	-	•	•	•	•	•	•	•	•	•	•	•	•	-	-
544	Australian HE MEPS	-	-	-	-	-	-	-	-	-	-	-	-	-	-	-
546	SABS rating plate	-	-	-	-	-	-	-	-	-	-	-	-	-	-	-
552	BIS licence for India	-	-	•	•	•	•	•	•	•	•	•	•	•	-	-
558	Saudi Arabian MEPS (SASO)	-	-	-	-	-	-	-	-	-	-	-	-	-	-	-
564	Singapore MEPS	-	-	-	-	-	-	-	-	-	-	-	-	-	-	-
586	Fulfilling UK Conformity Assessment (UKCA) requirements.	-	-	-	-	-	-	-	-	-	-	-	-	-	-	-
598	Universal motor	-	-	-	-	-	-	-	-	-	-	-	-	-	-	-
758	Saudi Aramco design.	-	-	-	-	-	-	-	-	-	-	-	-	-	-	-
811	JIP-33 standard design	-	-	-	-	-	-	-	-	-	-	-	-	-	-	-
822	WIMES 3.03i6 Compliant Design for DOL operation	•	•	•	•	•	•	-	-	-	-	-	-	•	•	•
823	WIMES 3.03i6 Compliant Design for VSD operation	•	•	•	•	•	•	•	•	•	•	•	•	•	•	•
841	Shell DEP 33.66.05.31-GEN February 2022	-	-	-	-	-	-	-	-	-	-	-	-	-	-	-
Stator winding temperature sensors																
121	Bimetal detectors, break type (NCC), (3 in series), 130 °C, in stator winding	•	•	•	•	•	•	•	•	•	•	•	•	•	•	•
122	Bimetal detectors, break type (NCC), (3 in series), 150 °C, in stator winding	•	•	•	•	•	•	•	•	•	•	•	•	•	•	•
123	Bimetal detectors, break type (NCC), (3 in series), 170 °C, in stator winding	•	•	•	•	•	•	•	•	•	•	•	•	•	•	•
124	Bimetal detectors, break type (NCC), (3 in series), 140 °C, in stator winding	-	-	-	-	-	-	-	-	-	-	•	•	•	•	•
125	Bimetal detectors, break type (NCC), (2x3 in series), 150 °C, in stator winding	-	-	-	-	-	•	•	•	•	•	•	•	•	•	•
127	Bimetal detectors, break type (NCC), (3 in series, 130 °C & 3 in series, 150 °C), in stator winding	•	•	•	•	•	•	•	•	•	•	•	•	•	•	•
435	PTC - thermistors (3 in series), 130 °C, in stator winding	•	•	•	•	•	•	•	•	•	•	•	•	•	•	•
437	PTC - thermistors (3 in series), 170 °C, in stator winding	•	•	•	•	•	•	•	•	•	•	•	•	•	•	•
438	PTC - thermistors (3 in series), 190 °C, in stator winding	-	-	-	-	-	-	-	-	-	-	-	-	-	-	-
439	PTC - thermistors (2x3 in series), 150 °C, in stator winding	•	•	•	•	•	•	•	•	•	•	•	•	•	•	•
441	PTC - thermistors (3 in series, 130 °C & 3 in series, 150 °C), in stator winding	•	•	•	•	•	•	•	•	•	•	•	•	•	•	•
442	PTC - thermistors (3 in series, 150 °C & 3 in series, 170 °C), in stator winding	•	•	•	•	•	•	•	•	•	•	•	•	•	•	•
445	Pt100 2-wire in stator winding, 1 per phase	•	•	•	•	•	•	•	•	•	•	•	•	•	•	•
446	Pt100 2-wire in stator winding, 2 per phase	-	-	-	-	-	•	•	•	•	•	•	•	•	•	•
502	Pt100 3-wire in stator winding, 1 per phase	-	-	-	-	-	•	•	•	•	•	•	•	•	•	•
503	Pt100 3-wire in stator winding, 2 per phase	-	-	-	-	-	•	•	•	•	•	•	•	•	•	•
511	PTC thermistors (2 x 3 in series), 130 °C, in stator winding	-	-	-	-	-	•	•	•	•	•	•	•	•	•	•
515	Pt100 3-wire in stator winding, 3 per phase	-	-	-	-	-	-	-	-	-	-	•	•	•	•	•
Terminal box																
019	Larger than standard terminal box.	•	•	•	•	•	•	-	-	-	-	•	•	•	•	-
020	Detached terminal box.	-	-	-	-	-	•	•	•	•	•	•	•	•	•	•
021	Terminal box LHS (seen from D-end).	•	•	•	•	•	•	•	•	•	•	•	•	•	•	-
022	Cable entry LHS (seen from D-end).	•	•	•	•	•	•	•	•	•	•	•	•	•	•	•
157	Terminal box degree of protection IP65.	-	-	-	-	-	•	•	•	•	•	•	•	•	•	-
180	Terminal box RHS (seen from D-end).	•	•	•	•	•	•	•	•	•	•	•	•	•	•	-
230	Standard metal cable gland.	•	•	•	•	•	•	•	•	•	•	•	•	•	-	-
277	Cable sealing end unit, size small for C-opening	-	-	-	-	-	-	-	-	-	-	•	-	-	-	-
278	Cable sealing end unit, size medium for D-opening	-	-	-	-	-	-	-	-	-	-	•	•	•	•	•
279	Cable sealing end unit, size large for D-opening	-	-	-	-	-	-	-	-	-	-	•	•	•	•	•
292	Adapter C-C	-	-	-	-	-	-	-	-	-	-	•	-	-	-	-
293	Adapter D-D	-	-	-	-	-	-	-	-	-	-	•	•	•	-	-
294	Adapter E-D	-	-	-	-	-	-	-	-	-	-	-	•	•	•	•
295	Adapter E-2D	-	-	-	-	-	-	-	-	-	-	-	•	•	○	○
296	Adapter E-3D	-	-	-	-	-	-	-	-	-	-	-	-	-	•	•
351	Terminal block turned according to cable entry	-	-	-	-	-	-	-	-	-	-	•	•	•	•	•
375	Standard plastic cable gland	•	•	•	•	•	•	•	•	•	•	•	-	-	-	-
380	Separate terminal box for temperature detectors, std. material	-	-	-	-	-	•	•	•	•	•	•	•	•	•	•
400	4 x 90 degr turnable terminal box.	•	•	•	•	•	•	○	○	○	○	○	○	○	-	-
413	Extended cable connection, no terminal box.	-	-	-	-	-	•	•	•	•	•	•	•	•	•	•
418	Separate terminal box for auxiliaries, standard material.	•	•	•	•	•	•	•	•	•	•	•	•	•	•	•
444	Adapter E-2E	-	-	-	-	-	-	-	-	-	-	-	-	-	-	-
447	Top mounted separate terminal box for monitoring equipment.	-	-	-	-	-	-	-	-	-	-	•	•	•	•	•
466	Terminal box at N-end.	-	-	-	-	-	•	•	•	•	•	•	•	•	•	•
467	Lower than standard terminal box and rubber extended cable. Cable length 2 m	-	-	-	-	-	•	•	•	•	•	-	-	-	-	-

○ = Included as standard | • = Available as option | - = Not applicable

Code/Variants	Frame size															
	71	80	90	100	112	132	160	180	200	225	250	280	315	355	400	450
468	•	•	•	•	•	•	•	•	•	•	•	•	•	•	•	•
469	•	•	•	•	•	•	•	•	•	•	•	•	•	•	•	•
553	•	•	•	•	•	•	•	•	•	•	•	•	•	•	•	•
554	-	-	-	-	-	-	•	•	•	•	•	•	•	•	•	•
557	-	•	•	•	•	•	•	•	•	•	•	•	•	•	•	•
565	-	-	-	-	-	-	-	-	-	•	•	•	•	•	•	•
566	-	-	-	-	-	-	-	-	-	•	•	•	•	•	•	•
567	-	-	-	-	-	-	•	•	•	•	•	•	•	•	•	•
568	-	-	-	-	-	-	•	•	•	•	•	•	•	•	•	•
569	-	-	-	-	-	-	•	•	•	•	•	•	•	•	•	•
624	•	•	•	•	•	•	•	•	•	•	•	•	•	•	•	•
727	-	-	-	-	-	-	•	•	•	•	•	•	•	•	•	•
730	•	•	•	•	•	•	•	•	•	•	•	•	•	•	•	•
731	•	•	•	•	•	•	•	•	•	•	•	•	•	•	•	•
740	-	-	-	-	-	-	•	•	•	•	•	-	-	-	-	-
742	-	-	-	-	-	-	-	-	-	-	-	•	•	•	•	•
743	-	-	-	-	-	-	•	•	•	•	•	•	•	•	•	•
744	-	-	-	-	-	-	•	•	•	•	•	•	•	•	•	•
745	-	-	-	-	-	-	•	•	•	•	•	•	•	•	•	•
746	-	-	-	-	-	-	•	•	•	•	•	•	•	•	•	•
Testing																
145	•	•	•	•	•	•	•	•	•	•	•	•	•	•	•	•
146	•	•	•	•	•	•	•	•	•	•	•	•	•	•	•	•
148	•	•	•	•	•	•	•	•	•	•	•	•	•	•	•	•
149	-	-	-	-	-	-	•	•	•	•	•	-	-	-	-	-
150	•	•	•	•	•	•	•	•	•	•	•	•	•	•	•	•
222	•	•	•	•	•	•	•	•	•	•	•	•	•	•	•	•
560	•	•	•	•	•	•	•	•	•	•	•	•	•	•	•	•
561	•	•	•	•	•	•	•	•	•	•	•	•	•	•	•	•
562	•	•	•	•	•	•	•	•	•	•	•	•	•	•	•	•
760	•	•	•	•	•	•	•	•	•	•	•	•	•	•	•	•
761	-	-	-	-	-	-	•	•	•	•	•	•	•	•	•	•
762	•	•	•	•	•	•	•	•	•	•	•	•	•	•	•	•
763	-	-	-	-	-	-	•	•	•	•	•	•	•	•	•	•
764	-	-	-	-	-	-	•	•	•	•	•	•	•	•	•	•
Variable speed drives																
182	-	-	-	-	-	-	•	•	•	•	•	•	•	•	•	•
429	-	-	-	-	-	-	-	-	-	-	-	•	•	•	•	•
470	-	-	-	-	-	-	•	•	•	•	•	•	•	•	•	•
472	-	-	-	-	•	•	•	•	•	•	•	•	•	•	•	•
473	-	-	-	-	•	•	•	•	•	•	•	•	•	•	•	•
474	-	-	-	-	-	-	•	•	•	•	•	•	•	•	•	•
476	-	-	-	-	-	-	•	•	•	•	•	•	•	•	•	•
477	-	-	-	-	-	-	•	•	•	•	•	•	•	•	•	•
478	-	-	-	-	-	-	-	-	-	-	-	•	•	•	•	•
479	-	-	-	-	-	-	-	-	-	-	-	•	•	•	•	•
486	-	-	-	-	-	-	-	-	-	-	-	•	•	•	•	•
510	-	-	-	-	-	-	-	-	-	-	-	•	•	•	•	•

○ = Included as standard | ● = Available as option | - = Not applicable

Code/Variants	Frame size															
	71	80	90	100	112	132	160	180	200	225	250	280	315	355	400	450
570 Prepared for hollow shaft pulse tacho (L&L 503).	-	•	•	•	•	•	-	-	-	-	-	-	-	-	-	-
588 Shaft grounding device	-	-	-	-	-	•	•	•	•	•	•	•	•	•	•	•
658 Special tacho mounted, price category 1	-	-	-	-	-	-	•	•	•	•	•	•	•	•	•	•
659 Special tacho mounted, price category 2	-	-	-	-	-	-	•	•	•	•	•	•	•	•	•	•
660 Special tacho mounted, price category 3	-	-	-	-	-	-	•	•	•	•	•	•	•	•	•	•
701 Insulated bearing at N-end.	-	-	-	-	-	-	•	•	•	•	•	•	•	•	•	•
702 Insulated bearings at both ends	•	•	•	•	•	•	•	•	•	•	•	-	-	-	-	-
704 EMC cable entry.	•	•	•	•	•	•	•	•	•	•	•	•	•	•	•	•
Y/D starting																
118 Terminals for Y/D start at high speed (two speed windings).	-	-	-	-	-	-	-	-	-	-	-	-	•	•	-	-
119 Terminals for Y/D start at low speed (two speed windings).	-	-	-	-	-	-	-	-	-	-	-	-	•	•	-	-

○ = Included as standard | ● = Available as option | - = Not applicable

Mechanical design

Motor frame and drain holes

—
01 As standard, motor sizes 71 - 450 are delivered with drain holes and closable plugs.

Motor frame

The motor frame, end shields and main terminal box are made of cast iron. Feet are integrated with the frame.

Motors can be supplied for foot mounting, flange mounting, and combinations of these.

Drain holes

Motors are provided with drain holes fitted with closable plugs as standard. The plugs are made of plastic material and are delivered in open position.

When mounting arrangement differs from foot mounted IM B3, mention variant code 066 when ordering to ensure the drain plug is mounted in the lowest position.

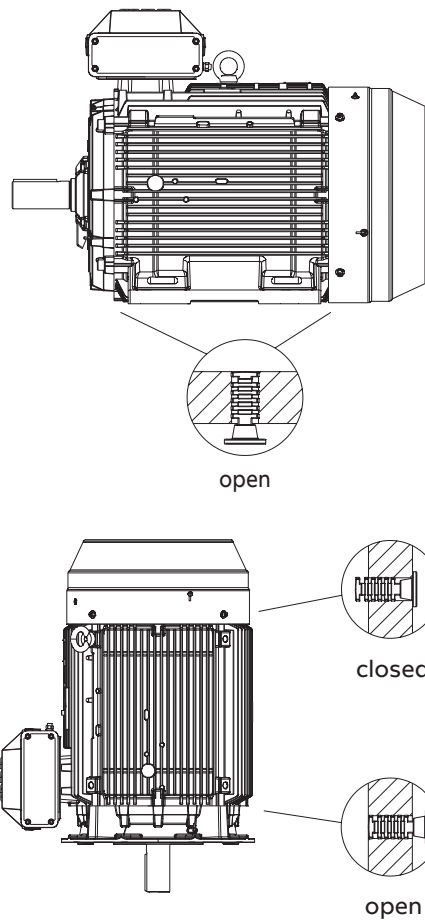

—
01

Lifting lugs

The motors are provided as standard with lifting lugs according to the table below. For improved lifting possibilities can variant code 305 be added, please refer to the variant code section for information about availability.

Frame size	Type of lugs	Foot mounted motors	Flange mounted motors
71, 80	No lugs, weight of motors is less than 25kg	-	-
90-132	Detachable eye bolt	2 pcs on top of motor diagonally placed, size M8	2 pcs on top of motor diagonally placed, size M8
160-200	Integrated in casting / detachable eye bolt	2 pcs on top of motor diagonally placed, integrated in frame casting	Locations for eye bolts: 4 pcs at N-end and 4 pcs at D-end. 2 pcs eye bolts size M12 delivered with each motor
225-250	Integrated in casting / detachable eye bolt	2 pcs on top of motor diagonally placed, integrated in frame casting	Locations for eye bolts: 4 pcs at N-end and 4 pcs at D-end. 2 pcs eye bolts size M16 delivered with each motor
280, 315	Detachable eye bolt	1 pc close to terminal box on top, size M24	Locations for eye bolts: 4 pcs at N-end and 4 pcs at D-end, one location on top close to terminal box. 2 pcs eye bolts size M24 delivered with each motor
355	Detachable eye bolt	1 pc close to terminal box on top, size M30	Locations for eye bolts: 4 pcs at N-end and 4 pcs at D-end, one location on top close to terminal box. 2 pcs eye bolts size M30 delivered with each motor
400	Detachable eye bolt	1 pc close to terminal box on top, size M36	Locations for eye bolts: 4 pcs at N-end and 4 pcs at D-end, one location on top close to terminal box. 2 pcs eye bolts size M36 delivered with each motor
450	Detachable eye bolt	Locations for eye bolts: 4 pcs at N-end and 4 pcs at D-end, one location on top close to terminal box. 3 pcs eye bolts size M42 delivered with each motor	Locations for eye bolts: 4 pcs at N-end and 4 pcs at D-end, one location on top close to terminal box. 2 pcs eye bolts size M42 delivered with each motor
500	Detachable eye bolt	Locations for eye bolts: 1 pc close to terminal box on top, size M48	-

Mechanical design

Heating elements

Heating elements are installed into windings to keep them free of corrosion in humid conditions. The required power of heating elements is shown in the table. You can order heating elements with variant code 450 or 451.

Motor size	71	80	90	100	112	132	160	180
Power (W)	25	25	25	25	25	25	25	25

Motor size	200	225	250	280	315	355	400	450	500
Power (W)	25	60	60	60	2x60	2x60	2x60	2x100	2x100

○ = Included as standard | ● = Available as option | - = Not applicable

Mechanical design

Bearings

Process performance motors are normally fitted with single-row deep-groove ball bearings, as shown in the table below.

If the bearing at the D-end is replaced with a roller bearing (NU- or NJ-), higher radial forces can be handled. Roller bearings are suitable for belt-drive applications and can be ordered with variant code 037.

When high axial forces are involved, angular-contact ball bearings should be used. When ordering a motor with an angular-contact ball bearing, also specify the method of mounting and the direction and magnitude of axial force to ensure that the optimal bearing system design is selected.

The variant codes for ordering angular-contact ball bearings at D-end are 058 and 060.

Standard and alternative designs

Shaft height	Product design code	Pole number	Standard design		Alternative designs	
			Deep groove ball bearings		Roller bearings (037)	Angular contact ball bearings (058, 060)
			Drive end	Non-drive end	Drive end	Drive end
71	B	2-8	6203-2Z/C3	6202-2Z/C3	NU 203 ECP/C3	7203 B
80	B, K	2-8	6204-2Z/C3	6203-2Z/C3	NU 204 ECP/C3	7204 B
90	B, K	2-8	6205-2Z/C3	6204-2Z/C3	NU 205 ECP/C3	7205 B
100	B, K	2-8	6206-2Z/C3	6205-2Z/C3	NU 206 ECP/C3	7206 B
100	M	2-8	6206-2Z/C3	6206-2Z/C3	NU 206 ECP/C3	7206 B
112	B	2-8	6206-2Z/C3	6205-2Z/C3	NU 206 ECP/C3	7206 B
112	K, M	2-8	6206-2Z/C3	6206-2Z/C3	NU 206 ECP/C3	7206 B
132	B, K, M	2-8	6208-2Z/C3	6208-2Z/C3	NU 208 ECP/C3	7208 B
160	G, K, M	2-12	6309/C3	6209/C3	NU 309 ECP/C3	7309 B
180	G, K, M	2-12	6310/C3	6209/C3	NU 310 ECP/C3	7310 B
200	G, K, M	2-12	6312/C3	6210/C3	NU 312 ECP/C3	7312 B
225	G, K, M	2-12	6313/C3	6212/C3	NU 313 ECP/C3	7313 B
250	G, K, M	2-12	6315/C3	6213/C3	NU 315 ECP/C3	7315 B
280	G, K, M, R	2	6316/C3	6316/C3	On request	7316 B
280	G, K, M, R	4-12	6316/C3	6316/C3	NU 316 ECP/C3	7316 B
315	G, K, M, R	2	6316/C3	6316/C3	On request	7316 B
315	G, K, M, R	4-12	6319/C3	6316/C3	NU 319 ECP/C3	7319 B
355	G, K, M, R	2	6316M/C3	6316M/C3	On request	7316 B
355	G, K, M, R	4-12	6322/C3	6316/C3	NU 322 ECP/C3	7322 B
400	G, K, M, R	2	6317M/C3	6317M/C3	On request	7317 B
400	G, K, M, R	4-12	6324/C3	6319/C3	NU 324 ECP/C3	7324 B
450	G, K, M, R	2	6317M/C3	6317M/C3	On request	7317 B
450	G, K, M, R	4-12	6326M/C3	6322/C3	NU 326 ECP/C3	7326 B
500	M, R	4-8	6330M/C3	6326/C3	NU 330 ECM/C3	N/A

Bearing life

The nominal life L_{10h} of a bearing is defined according to ISO 281 as the number of operating hours achieved or exceeded by 90 % of identical bearings in a large test series under specified conditions. 50 % of bearings achieve at least five times this lifetime.

The calculated bearing life L_{10h} for power transmission by means of coupling is for horizontally mounted motors in sizes up to 315 \geq 100,000 hours.

Lubrication

On delivery, motors in frame size 160 and above are pre-lubricated with high-quality grease.

Before first start-up, see instructions for re-lubrication and recommended grease in the installation, operation, maintenance and safety manual delivered together with the motor, or see the lubrication plate on the motor.

Motors with bearings greased for life

Motors in frame sizes 71–132 are equipped with bearings greased for life, while this is also available as an option for frame sizes 160–250. Bearings are lubricated with high-quality, high-temperature grease. Bearing types are stated on the rating plate.

The approximate lifetime of bearings in four-pole motors is about 40 000 duty hours. Lifetime is subject to the load conditions of the application run by the motor.

Motors with relubrication nipples

In frame sizes 160–500, the bearing system is provided with valve discs to ease lubrication. Motors are lubricated while running.

The grease outlet opening has closing valves at both ends. These should be opened before greasing and closed 1–2 hours after regreasing. This ensures that the construction is tight and bearings remain dust- and dirt-free.

A grease-collection method can be used optionally.

The following tables show lubrication intervals according to the L1 principle for various nominal speeds at a 25°C ambient temperature. These values apply to horizontally mounted motors (B3) with an 80°C bearing temperature and high-quality grease containing lithium-complex soap and mineral or PAO-oil.

Lubrication intervals in duty hours for ball bearings

Frame size	Amount of grease g/bearing	Amount of grease g/N-end	Speed 3600 r/min	Speed 3000 r/min	Speed 1800 r/min	Speed 1500 r/min	Speed 1000 r/min	Speed 0-900 r/min
Ball bearings								
Lubrication intervals in duty hours								
160	25	17	7100	8 900	14 300	16 300	20 500	21 600
180	30	17	6100	7800	13 100	15 100	19 400	20 500
200	40	18	4300	5900	11 000	13 000	17 300	18 400
225	50	25	3600	5100	10 100	12 000	16 400	17 500
250	60	28	2400	3700	8500	10400	14700	15 800
280	35	35	1900	3200	-	-	-	-
280	40	40	-	-	7800	9600	13 900	15 000
315	35	35	1900	3200	-	-	-	-
315	55	40	-	-	5900	7600	11 800	12 900
355	35	35	1900	3200	-	-	-	-
355	70	40	-	-	4000	5600	9600	10 700
400	40	40	1500	2700	-	-	-	-
400	85	55	-	-	3200	4700	8600	9700
450	40	40	1500	2700	-	-	-	-
450	95	70	-	-	2500	3900	7700	8700
500	-	-	-	-	-	-	-	-
500	120	95	-	-	1400	2600	6000	7000

Lubrication intervals in duty hours for roller bearings

Frame size	Amount of grease g/bearing	Amount of grease g/N-end	Speed 3600 r/min	Speed 3000 r/min	Speed 1800 r/min	Speed 1500 r/min	Speed 1000 r/min	Speed 0-900 r/min
Roller bearings								
Lubrication intervals in duty hours								
160	25	17	3600	4500	7200	8 100	10 300	10 800
180	30	17	3000	3900	6600	7500	9 700	10 200
200	40	18	2100	3000	5500	6500	8 600	9 200
225	50	25	1800	2600	5100	6000	8 200	8 700
250	60	28	-	1900	4200	5200	7300	7900
280	35	35	-	1600	-	-	-	-
280	40	40	-	-	3900	4800	6900	7500
315	35	35	-	1600	-	-	-	-
315	55	40	-	-	2900	3800	5900	6500
355	35	35	-	1600	-	-	-	-
355	70	40	-	-	2000	2800	4800	5400
400	40	40	-	1300	-	-	-	-
400	85	55	-	-	1600	2400	4300	4800
450	40	40	-	1300	-	-	-	-
450	95	70	-	-	1300	2000	3800	4400
500	-	-	-	-	-	-	-	-
500	120	95	-	-	700	1300	3000	3500

Axially-locked bearings

All motors with deep groove ball bearings are equipped with an axially locked bearing at the D-end, as a standard feature.

Transport locking

Motors with roller bearings or an angular-contact ball bearing are fitted with a transport lock before dispatch to prevent damage to the bearings during transport. A warning sign is attached to motors when transport locking is used.

Locking may also be fitted in other cases if severe transport conditions are expected.

Bearing seals

Motor size	Efficiency class	Product design code	Pole	Standard design		Alternative designs	
				D-end	N-end	Labyrinth seal at D-end (variant code 783)	Radial seal at D-end (variant code 072)
71	all	all	2-8	Gamma seal	Gamma seal	NA	Radial seal
80	all	all	2-8	Gamma seal	Gamma seal	NA	Radial seal
90	all	all	2-8	Gamma seal	Gamma seal	NA	Radial seal
100	all	all	2-8	Gamma seal	Gamma seal	NA	Radial seal
112	all	all	2-8	Gamma seal	Gamma seal	NA	Radial seal
132	all	all	2-8	Gamma seal	Gamma seal	NA	Radial seal
160	all	all	2-12	Gamma seal	Gamma seal	Labyrinth seal	Radial seal
180	all	all	2-12	Gamma seal	Gamma seal	Labyrinth seal	Radial seal
200	all	all	2-12	Gamma seal	Gamma seal	Labyrinth seal	Radial seal
225	all	all	2-12	Gamma seal	Gamma seal	Labyrinth seal	Radial seal
250	all	all	2-12	Gamma seal	Gamma seal	Labyrinth seal	Radial seal
280	IE2	G	2	Labyrinth seal	V ring	Standard	NA
280	IE3, IE4, IE5	K, M, R	2	Labyrinth seal	Labyrinth seal	Standard	NA
280	IE2	G	4-12	V ring	V ring	Labyrinth seal	NA
280	IE3, IE4, IE5	K, M, R	4-12	Labyrinth seal	Labyrinth seal	Standard	NA
315	IE2	G	2	Labyrinth seal	V ring	Standard	NA
315	IE3, IE4, IE5	K, M, R	2	Labyrinth seal	Labyrinth seal	Standard	NA
315	IE2	G	4-12	V ring	V ring	Labyrinth seal	NA
315	IE3, IE4, IE5	K, M, R	4-12	Labyrinth seal	Labyrinth seal	Standard	NA
315LK_	IE2	G	2-12	Labyrinth seal	V ring	Standard	NA
315LK_	IE3, IE4, IE5	K, M, R	2-12	Labyrinth seal	Labyrinth seal	Standard	NA
355	IE2	G	2-12	Labyrinth seal	V ring	Standard	NA
355	IE3, IE4, IE5	K, M, R	2-12	Labyrinth seal	Labyrinth seal	Standard	NA
400	all	G,K,M, R	2	Labyrinth seal	Labyrinth seal	Standard	NA
400	IE2	G	4-12	Labyrinth seal	V ring	Standard	NA
400	IE3, IE4, IE5	K,M, R	4-12	Labyrinth seal	Labyrinth seal	Standard	NA
450	all	G,K,M, R	2-12	Labyrinth seal	Labyrinth seal	Standard	NA
500	all	M, R	4-8	Labyrinth seal	Labyrinth seal	Standard	NA

Standard design examples

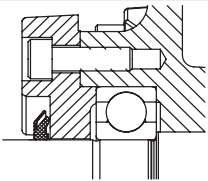
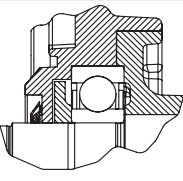
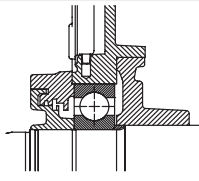
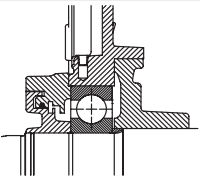
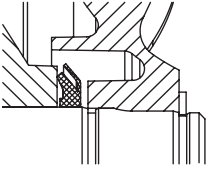
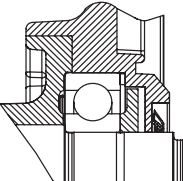
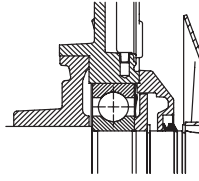
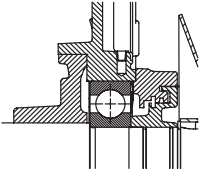
D-end				
N-end				
Motor size, seal type D-end/N-end	71-132, gamma/gamma seal	160-250, gamma/gamma seal	See above table for motor sizes, labyrinth/V-ring seal.	See above table for motor sizes, labyrinth/labyrinth seal.

Mechanical design

Radial forces

The following table shows permissible radial forces on the shaft in Newtons, assuming zero axial force, a 25 °C ambient temperature, and normal conditions. The values are given for a calculated bearing life of 20 000 and 40 000 hours at 60 Hz.

These calculated values further assume mounting position IM B3 (foot-mounted), with force directed sideways. In some cases, the strength of the shaft affects permissible forces.

Permissible loads of simultaneous radial and axial forces can be supplied on request.

If the radial force is applied between points X_0 and X_{max} , the permissible force F_R can be calculated with the following formula:

$$F_R = F_{X_0} - \frac{X}{E} (F_{X_0} - F_{X_{max}})$$

Where

E length of the shaft extension in the standard version

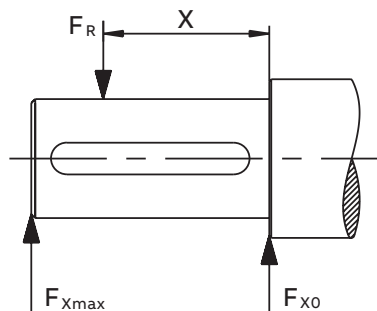

Permissible radial forces - Mounting arrangement IM B3

Motor size	Poles	Length of shaft extension	Basic design with deep groove ball bearings				Roller bearings			
			Mounting arrangement IM B3				Mounting arrangement IM B3			
			20,000 h		40,000 h		20,000 h		40,000 h	
			F_{xo} N	F_{xmax} N	F_{xo} N	F_{xmax} N	F_{xo} N	F_{xmax} N	F_{xo} N	F_{xmax} N
71	2	30	540	460	420	360	1285	650	1040	650
	4	30	700	605	555	480	1615	650	1310	650
	6	30	780	665	620	530	1640	650	1450	650
	8	30	860	730	685	580	1640	600	1580	600
80	2	40	710	600	385	350	1910	865	1555	865
	4	40	940	810	725	625	2335	865	1945	865
	6	40	1060	895	840	710	2335	865	2160	865
	8	40	1185	1020	940	810	2335	865	2335	865
90	2	50	820	690	650	545	2205	1330	1790	1330
	4	50	1035	870	820	690	2715	1330	2205	1330
	6	50	1185	995	940	790	3065	1330	2490	1330
	8	50	1300	1095	1035	870	3340	1330	2715	1330
100	2	60	1130	925	900	735	2905	1900	2360	1900
	4	60	1425	1165	1135	925	3575	1900	2905	1900
	6	60	1635	1335	1295	1060	4040	1900	3280	1900
	8	60	1820	1520	1445	1205	4460	1900	3620	1900
112	2	60	1170	980	925	775	3000	1970	2435	1970
	4	60	1475	1235	1170	980	3695	1970	3000	1970
	6	60	1690	1310	1340	1120	4170	1970	3390	1970
	8	60	1860	1310	1475	1235	4550	1970	3695	1970
132	2	80	1840	1500	1460	1190	4255	3465	3455	2815
	4	80	2320	1890	1840	1500	5240	4265	4255	3465
	6	80	2660	2165	2110	1715	5915	3680	4805	3680
	8	80	2925	2380	2320	1890	6450	3680	5240	3680
160 MLA	2	110	3540	2740	2955	2285	7100	4300	6140	4300
	4	110	4000	3100	3325	2570	8000	4300	6870	4300
	6	110	4170	3200	3440	2655	8600	4300	7270	4300
	8	110	4600	3585	3855	2985	9300	4300	7955	4300
160 MLB	2	110	3540	2740	2955	2270	7085	4300	6070	4300
	4	110	4085	3300	3370	2725	8300	4300	7055	4300
	6	110	4100	3355	3400	2755	8600	4300	7300	4300
	8	110	4200	3270	3455	2670	9000	4300	7570	4300
160 MLC	2	110	3400	2600	2855	2200	6800	4300	5885	4300
	4	110	3700	3000	3070	2485	7800	4300	6640	4300
	6	110	3600	2900	2870	2325	8000	4300	6700	4300
	8	110	4170	3370	3370	2725	9000	4300	7585	4300
160 MLD	2	110	3585	2900	3000	2440	7100	4300	6140	4300
	4	110	3400	2755	2755	2240	7600	4300	6370	4300
160 MLE	2	110	3185	2570	2640	2140	6785	4300	5770	4300
180 MLA	2	110	4100	3385	3455	2825	8125	5500	7025	5500
	4	110	4270	3485	3525	2885	8600	5500	7300	5500
	6	110	4700	3800	3855	3155	9400	5500	7900	5500
	8	110	4785	3900	3870	3170	9800	5500	8255	5500
180 MLB	2	110	4170	3400	3470	2825	7900	5500	6770	5500
	4	110	4185	3400	3440	2810	8500	5500	7200	5500
	6	110	4370	3570	3525	2885	9000	5500	7600	5500
180 MLC	4	110	3700	3055	3010	2470	7900	5500	6655	5440
200 MLA	2	110	5600	4685	4700	3925	10900	9100	9470	7900
	4	110	6285	5200	5240	4370	12500	9550	10700	8900
	6	110	6800	5700	5700	4770	13600	9550	11670	9550
	8	110	6800	5700	5600	4685	14100	9550	12000	9550
200 MLB	2	110	5670	4700	4700	3925	11000	9200	9500	7900
	4	110	5700	4700	4700	3925	12000	9550	10185	8500
	6	110	6400	5370	5300	4425	13200	9550	11200	9385
200 MLC	2	110	5000	4185	4185	3500	10400	8700	8900	7455
	4	110	5400	4500	4425	3685	11600	9550	9800	8200
	6	110	5800	4885	4740	3955	12500	9550	10600	8800
200 MLD	2	110	4985	4170	4170	3485	10400	8700	8900	7400
225 SMA	2	110	6400	5400	5355	4500	13300	10700	11500	9700
	4	140	7300	5900	6155	4970	15400	10250	13200	10250
	6	140	7600	6200	6370	5140	16400	10250	14000	10250
	8	140	8500	6900	7100	5725	17900	10250	15300	10250

Motor size	Poles	Length of shaft extension	Basic design with deep groove ball bearings				Roller bearings			
			Mounting arrangement IM B3				Mounting arrangement IM B3			
			20,000 h		40,000 h		20,000 h		40,000 h	
			F _{xo} N	F _{xmax} N	F _{xo} N	F _{xmax} N	F _{xo} N	F _{xmax} N	F _{xo} N	F _{xmax} N
225 SMB	2	110	6100	5185	5155	4340	13000	10700	11200	9455
	4	140	7085	5700	5885	4755	15100	10250	12900	10250
	6	140	7100	5700	5840	4700	16000	10250	13500	10250
	8	140	8000	6485	6600	5340	17300	10250	14700	10250
225 SMC	2	110	5600	4700	4685	3940	12600	10600	10770	9070
	4	140	6400	5200	5300	4285	14500	10250	12385	10000
225 SMD	2	110	5500	4640	4600	3880	12420	10460	10640	8960
	4	140	5800	4700	4725	3800	13500	10250	11400	9270
250 SMA	2	140	7700	6285	6500	5285	17100	10900	14900	10900
	4	140	8700	7000	7300	5900	19800	13800	17000	13785
	6	140	9400	7600	7800	6355	21600	13800	18400	13800
	8	140	9600	7800	7900	6400	22700	13800	19300	13800
250 SMB	2	140	7100	5800	6000	4885	16700	10900	14400	10900
	4	140	7800	6300	6470	5240	18900	13800	16200	13100
	6	140	8900	7200	7355	5955	21200	13800	18000	13800
250 SMC	2	140	6800	5500	5670	4600	16300	10900	14000	10900
	4	140	7400	6000	6055	4900	18100	13800	15400	12485
	6	140	8200	6600	6670	5400	20300	13800	17200	13800
280 SM_	2	140	7300	6000	5800	4900	20400	6000	16500	6000
	4	140	9200	7800	7300	6200	25100	9200	20300	9200
	6	140	10600	8900	8400	7000	28300	9200	23000	9200
	8	140	11700	9200	9200	7800	30900	9200	25100	9200
280 ML_	2	140	7400	6200	5800	5000	20600	6200	16700	6200
	4	140	9200	7900	7300	6200	25000	9500	20300	9500
	6	140	10500	9000	8300	7100	28300	9400	22900	9400
	8	140	11600	9500	9200	7900	30800	9500	25000	9500
315 SM_	2	140	7300	6000	5800	4950	20300	6000	16500	6000
	4	170	11400	9400	9000	7450	32500	9600	26600	9600
	6	170	13000	9600	10300	8500	37000	9600	30000	9600
	8	170	14400	9600	11400	9400	40300	9600	32700	9600
315 ML_	2	140	7400	6400	5850	5050	20600	5850	16700	5850
	4	170	11500	9700	9100	7650	32700	13600	26500	13600
	6	170	13200	11100	10400	8800	36900	13600	29900	13600
	8	170	14500	12200	11500	9700	40200	13600	32600	13600
315 LK_	2	140	7400	6550	5800	5150	20800	5550	16800	5550
	4	170	11500	10000	9100	7850	33100	13350	26800	13350
	6	170	13200	11400	10450	9050	37300	13350	30300	13350
	8	170	14600	12600	11550	10000	40800	13350	33100	13350
355 SM_	2	140	7350	6450	5750	5050	20600	7200	16700	7200
	4	210	15200	12600	12000	9950	45500	14000	36900	14000
	6	210	17500	14000	13800	11400	51400	14000	41700	14000
	8	210	19300	14000	15250	12600	56000	14000	45500	14000
355 ML_	2	140	7350	6550	5750	5100	20800	6750	16800	6750
	4	210	15300	12900	12000	10100	45900	13600	37200	13600
	6	210	17600	13600	13900	11600	51500	13600	42100	13600
	8	210	19400	13600	15300	12900	56000	13600	45900	13600
355 LK_	2	140	7350	6650	5650	5100	21000	6550	17000	6550
	4	210	15200	13000	11850	10200	46000	13000	37300	13000
	6	210	17500	13000	13700	11900	52000	13000	42000	13000
	8	210	19400	13000	15200	13000	56500	13000	46000	13000
400 L_	2	170	7650	6850	4400	3900	23900	9050	19350	9050
	4	210	15600	13550	12150	10550	52500	16000	43300	16000
	6	210	17800	15450	13850	12000	60000	16000	48800	16000
	8	210	19700	16000	15350	13350	65700	16000	53200	16000
400 LK_	2	170	7650	6850	4400	3900	23900	9050	19350	9050
	4	210	15600	11500	12150	10550	52500	11500	43300	11500
	6	210	17800	11500	13850	11500	60000	11500	48800	11500
	8	210	19700	11500	15350	11500	65700	11500	53200	11500
450 L_	2	170	7400	6700	3500	3300	24000	7500	19000	7500
	4	210	17000	15200	13000	11600	62000	25000	50000	25000
	6	210	19000	17000	14000	13000	70000	24000	56000	24000
	8	210	21300	19000	16500	14600	76000	23000	62000	23000
500 L_	4	250	19480	17160	14660	12920	88500	77990	71730	63210
	6	250	22740	20040	17380	15310	100040	88150	81120	71480
	8	250	25290	22280	19460	17140	109100	96150	88490	77980

Mechanical design

Axial forces

The following tables present permissible axial forces on the shaft in Newtons, assuming zero radial force, a 25 °C ambient temperature, and normal conditions. The values are given for a calculated bearing life of 20,000 and 40,000 hours per motor size.

At 60 Hz, the values must be reduced by 10 percent, and for two-speed motors, the higher speed determines permissible axial force. Permissible loads of simultaneous radial and axial forces can be supplied on request.

For axial force F_{AD} , it is assumed that the D-bearing is locked with a locking ring.

Permissible axial forces

Motor size	Poles	Length of shaft extension	Mounting arrangement IM B3				Mounting arrangement IM V1			
			20,000 h		40,000 h		20,000 h		40,000 h	
			F_{AD} N	F_{AZ} N	F_{AD} N	F_{AZ} N	F_{AD} N	F_{AZ} N	F_{AD} N	F_{AZ} N
71	2	30	615	285	505	175	630	275	520	165
	4	30	760	430	615	285	790	410	645	265
	6	30	870	540	695	365	890	525	720	355
	8	30	960	630	765	435	985	615	785	415
80	2	40	880	300	735	155	915	280	770	135
	4	40	1075	495	880	300	1130	455	935	260
	6	40	1215	635	985	405	1270	600	1040	370
	8	40	1330	750	1070	490	1400	705	1140	450
90	2	50	780	500	620	340	840	455	680	300
	4	50	985	705	775	495	1070	650	860	440
	6	50	1140	860	890	610	1225	800	975	555
	8	50	1265	985	985	705	1355	925	1075	645
100	2	60	925	570	735	350	1285	510	1060	290
	4	60	1480	860	1190	570	1600	780	1305	490
	6	60	1690	1070	1350	730	1815	995	1470	650
	8	60	1865	1245	1480	860	1995	1160	1610	775
112	2	60	1155	595	935	375	1290	505	1070	280
	4	60	1445	885	1155	595	1595	785	1300	495
	6	60	1655	1095	1315	755	1810	995	1465	650
	8	60	1830	1270	1445	885	1985	1170	1600	780
132	2	80	1765	965	1420	620	1925	855	1580	510
	4	80	2210	1410	1755	955	2420	1270	1965	815
	6	80	2535	1735	2000	1200	2770	1580	2235	1045
	8	80	2800	2000	2205	1405	3055	1835	2455	1235
160 MLA	2	110	2850	2850	2325	2325	3100	2578	2570	2048
	4	110	3450	3450	2775	2775	3820	3150	3120	2450
	6	110	3690	3690	2970	2970	4100	3410	3325	2635
	8	110	4155	4155	3315	3315	4440	3845	3640	3045
160 MLB	2	110	2850	2850	2325	2325	3120	2570	2580	2030
	4	110	3435	3435	2760	2760	3880	3085	3180	2385
	6	110	3600	3600	2880	2880	4120	3240	3360	2480
	8	110	3750	3750	2970	2970	4140	3450	3340	2650
160 MLC	2	110	2775	2775	2280	2280	3080	2500	2560	1980
	4	110	3150	3150	2535	2535	3620	2770	2985	2135
	6	110	3135	3135	2490	2490	3680	2700	3005	2025
	8	110	3675	3675	2910	2910	4240	3260	3445	2465
160 MLD	2	110	2865	2865	2330	2330	3220	2540	2665	1985
	4	110	2900	2900	2320	2320	3420	2470	2820	1870

Motor size	Poles	Length of shaft extension	Mounting arrangement IM B3				Mounting arrangement IM V1			
			20,000 h		40,000 h		20,000 h		40,000 h	
			F _{AD} N	F _{AZ} N	F _{AD} N	F _{AZ} N	F _{AD} N	F _{AZ} N	F _{AD} N	F _{AZ} N
160 MLE	2	110	2500	2500	2025	2025	2900	2150	2420	1670
180 MLA	2	110	3300	3300	2700	2700	3660	2940	3060	2340
	4	110	3600	3600	2920	2920	4160	3150	3460	2450
	6	110	4140	4140	3320	3320	4800	3675	3940	2815
	8	110	4220	4220	3360	3360	4960	3740	4040	2820
180 MLB	2	110	3340	3340	2725	2725	3760	2960	3125	2320
	4	110	3580	3580	2900	2900	4220	3095	3500	2375
	6	110	3800	3800	3040	3040	4500	3285	3700	2485
180 MLC	4	110	3220	3220	2560	2560	3880	2660	3220	2000
200 MLA	2	110	4460	4460	3640	3640	5000	3965	4200	3125
	4	110	5000	5260	4260	4260	5000	4680	5000	3640
	6	110	5000	5480	4720	4720	5000	5265	5000	4065
200 MLB	2	110	4440	4440	3620	3620	5000	3905	4220	3085
	4	110	4720	4720	3840	3840	5000	4060	4700	3120
	6	110	5000	5480	4420	4420	5000	4800	5000	3660
200 MLC	2	110	3940	3940	3180	3180	4600	3385	3880	2665
	4	110	4480	4480	3620	3620	5000	3775	4520	2875
	6	110	4980	4980	3980	3980	5000	4165	5000	3105
200 MLD	2	110	3940	3940	3200	3200	4660	3370	3925	2635
225 SMA	2	110	4980	4980	4060	4060	5000	4375	4780	3455
	4	140	5000	6080	4920	4920	5000	5445	5000	4225
	6	140	5000	6520	5000	5260	5000	5735	5000	4395
	8	140	5000	7420	5000	5960	5000	6535	5000	5095
225 SMB	2	110	4860	4860	3960	3960	5000	4245	4780	3345
	4	140	5000	5880	4780	4780	5000	5175	5000	3995
	6	140	5000	6020	4840	4840	5000	5155	5000	3915
	8	140	5000	6940	5000	5560	5000	6055	5000	4635
225 SMC	2	110	4380	4380	3540	3540	5000	3670	4440	2900
	4	140	5000	5240	4260	4260	5000	4445	5000	3425
225 SMD	2	110	4320	4320	3480	3480	5000	3590	4400	2790
	4	140	4800	4800	3820	3820	5000	3895	5000	2935
250 SMA	2	140	6000	6080	4920	4920	6000	5345	5840	4225
	4	140	6000	7140	5820	5820	6000	6300	6000	4920
	6	140	6000	7880	6000	6380	6000	6950	6000	5350
	8	140	6000	8200	6000	6600	6000	7125	6000	5385
250 SMB	2	140	5620	5620	4540	4540	6000	4830	5640	3810
	4	140	6000	6320	5100	5100	6000	5325	6000	4085
	6	140	6000	7480	6000	6040	6000	6370	6000	4830
250 SMC	2	140	5260	5260	4220	4220	6000	4395	5400	3415
	4	140	5960	5960	4760	4760	6000	4900	6000	3700
	6	140	6000	6860	5520	5520	6000	5575	6000	4135
280 SM_	2	140	6200	4250	4900	2900	7550	3150	6200	1800
	4	140	8000	6000	6250	4250	9600	4550	7800	2750
	6	140	7250	9250	7150	5150	11150	5500	9000	3350
	8	140	10300	8300	7950	5950	12200	7000	9850	4700
280 ML_	2	140	6100	4100	4800	2800	8150	2750	6800	1400
	4	140	7800	5800	6000	4000	10450	4050	8650	2250
	6	140	8950	6950	6900	4900	12350	4750	10250	2600
	8	140	10000	8000	7700	5700	13450	5800	11050	3450
315 SM_	2	140	6180	4200	4850	2850	7950	2600	6600	1300
	4	170	9400	7400	7250	5250	11750	5500	9550	3300
	6	170	10900	8900	8350	6350	13600	6300	11050	3750
	8	170	12000	10000	9200	7000	15350	7900	12450	5000
315 ML_	2	140	6050	4050	4750	2750	8650	2300	7300	1) 2900
	4	170	9250	7250	7100	5100	12500	5050	10300	2900
	6	170	10650	8650	8100	6100	14900	5800	12350	3250
	8	170	11500	9900	8900	6800	15400	6300	13600	3400
315 LK_	2	140	6000	3950	4650	2650	9100	1350	7750	1) 2900
	4	170	9100	7150	7000	5000	13100	3850	10900	1700
	6	170	10500	8500	7950	5950	15700	4100	13100	1550
	8	170	11750	9750	8900	6900	16900	6300	14100	3450
355 SM_	2	140	3050	6850	1750	5550	6350	4250	4950	2900
	4	210	8600	12400	5900	9700	13250	8600	10450	5850
	6	210	10550	14350	7300	11100	15650	9580	12350	6270
	8	210	12200	16000	8550	12350	17350	12500	13600	8900

Motor size	Poles	Length of shaft extension	Mounting arrangement IM B3				Mounting arrangement IM V1			
			20,000 h		40,000 h		20,000 h		40,000 h	
			F _{AD} N	F _{AZ} N	F _{AD} N	F _{AZ} N	F _{AD} N	F _{AZ} N	F _{AD} N	F _{AZ} N
355 ML_	2	140	2900	6700	1600	5400	7100	3700	5750	2350
	4	210	8360	12150	5650	9450	14600	7950	11850	5150
	6	210	10100	13900	6900	10700	18050	8600	14700	5300
	8	210	12000	15800	7300	11000	21100	11650	17000	7600
355 LK_	2	140	2650	6450	1350	5150	8250	2650	6900	1300
	4	210	8200	12000	5450	9250	15650	6600	12850	3800
	6	210	9900	13700	6700	10500	19100	7050	15800	3750
	8	210	11450	15250	7800	11600	21200	8700	17500	5000
400 L, LK_	2	170	2150	7150	1)	5800	8650	2150	7220	1)
	4	210	7100	13100	4300	10300	16050	6400	13150	3400
	6	210	8850	14850	5500	11500	18450	6750	15100	3400
	8	210	10450	16450	6750	12750	20100	8350	16450	4700
450 L_	2	170	1800	6800	1)	5500	11500	1)	10000	1)
	4	210	7600	13500	4500	10500	20000	4400	17700	1200
	6	210	9000	15000	5600	11500	26000	3700	22200	1)
	8	210	10800	16800	7000	12900	27800	5500	23700	1350
500 L_	4	250	8490	15190	4980	11680	N/A	N/A	N/A	N/A
	6	250	11080	17780	6910	13610	N/A	N/A	N/A	N/A
	8	250	13170	19870	8470	15170	N/A	N/A	N/A	N/A

¹⁾ On request.

Terminal box

Standard terminal box

Degree of protection and mounting options

The degree of protection for the standard terminal box is IP 55. By default, terminal boxes are mounted on top of the motor at the D-end. On request, the terminal box can also be mounted on the left or right side regardless of the motor size (see Mounting options).

Turnability

The standard terminal boxes for motor sizes 160–355 can be turned 4*90°, and in sizes 355–500, 2*180° after delivery. For sizes 400–500, it is also possible to mount a terminal box with an opening towards the D or N-end, using the relevant variant codes when ordering, this is needed to get the terminal block turned in the right position. For motors in size 71–132, a 4*90° turnable terminal box is optional- this can be ordered with variant code 400.

Cable entries

The terminal box is provided with tapped holes for cable glands. No cable glands are included as standard, the entry holes are closed with blanking plugs made of plastic. Very large motors have an angle adapter between the terminal box and the cable gland. Please refer to the table on the next page for further information about the amount and size of threaded holes, plugs and cable sealing units provided as standard.

Different types of cable glands are available as an option. Please refer to the terminal box alternatives section for more details.

Cable type and terminations If no cable type is specified in the order, it will be a PVC-insulated non-armored cable, and its termination parts are determined as shown in the following table.

Terminations are suitable for copper and aluminum cables. Cables are connected to terminals by cable lugs, which are not included in the delivery.

Earthing bolts

The motors are as standard provided with at least one earthing bolt inside the terminal box and another on the frame. The earthing bolt on the frame is located on top close to the terminal box for easy access from either side of the motor.

See section Variant codes for all available options.

Shaft height	Product design code	Earthing on the frame	Earthing locations
71-100	B, K, M	2x M4	Top of the frame, one on each side
112	B	2x M4	Top of the frame, one on each side
112	K,M	2x M5	Top of the frame, one on each side
132	all	2x M5	Top of the frame, one on each side
160-250	all	2x M6 (with clamp)	Foot of the frame, RHS
280-400	all	2x M10	Top of the frame, near lifting lug
450 - 500	all	6x M10	2 at top of the frame / 2 additional earthings at foot of the frame, each side

Ordering

To ensure the delivery of desired terminations for the motor, state the cable type, quantity, size, and outer diameter when ordering. Non-standard designs of terminal boxes, such as non-standard size or higher degree of protection, are available as options.

See section Variant codes for all available options.

Terminal box

Standard delivery

Standard delivery if no other information is provided.

Shaft height	Product design code	Voltage code	Pole number	Terminal box type	Size of gland plate opening in the terminal box	45° angle adapter	Amount and size of thread	Plugged holes	Max, connectable core cross section mm ² / phase	Number and size of terminal bolts	Earthing in the main terminal box
71	B, K	S, D, E	2-8	integrated	-	-	2 x M16x1,5	2 x M16	1 x 2,5	6 x M4	1 x M4
80	B, K	S, D, E	2-8	integrated	-	-	2 x M25x1,5	2 x M25	1 x 4	6 x M4	1 x M4
90	B, K	S, D, E	2-8	integrated	-	-	2 x M25x1,5	2 x M25	1 x 6	6 x M5	1 x M4
100	B, K, M	S, D, E	2-8	integrated	-	-	2 x M32x1,5	2 x M32	1 x 10	6 x M5	1 x M4
112	B	S, D, E	2-8	integrated	-	-	2 x M32x1,5	2 x M32	1 x 10	6 x M5	1 x M4
112	K, M	S, D, E	2-8	integrated	-	-	2 x M32x1,5	2 x M32	1 x 10	6 x M5	1 x M5
132	B, K, M	S, D, E	2-8	integrated	-	-	2 x M32x1,5	2 x M32	1 x 10	6 x M5	1 x M5
160	G, K, M	S, D, E	2-8	63	B	-	2 x M40x1,5	2 x M40	1 x 35	6 x M6	1 x M6
180	G, K, M	S, D, E	2-8	63	B	-	2 x M40x1,5	2 x M40	1 x 35	6 x M6	1 x M6
200 - 250	G, K, M	S, D, E	2-8	160	C	-	2 x M63x1,5	2 x M63	1 x 70	6 x M10	1 x M6
280	R	S, D, E	2-6	210	C	-	2 x M63x1,5	2 x M63	2 x 150	6 x M12	2 x M10
280SM_	G, K, M	S, D, E	2-8	210	C	-	2 x M63x1,5	2 x M63	2 x 150	6 x M12	2 x M10
280ML_	G, K, M	D, E	2-4	370	D	-	2 x M63x1,5	2 x M63	2 x 240	6 x M12	2 x M10
280ML_	G, K, M	D, E	6-8	210	C	-	2 x M63x1,5	2 x M63	2 x 150	6 x M12	2 x M10
315	R	D, E	2-6	370	D	-	2 x M63x1,5	2 x M63	2 x 240	6 x M12	2 x M10
315SM_, ML_	G, K, M	D, E	2-8	370	D	-	2 x M63x1,5	2 x M63	2 x 240	6 x M12	2 x M10
315LKA, LKB	G, K, M	D, E	2-8	370	D	-	2 x M63x1,5	2 x M63	2 x 240	6 x M12	2 x M10
315LKC	G	D, E	2-4	750	E	-	2 x M75x1,5	1 x M75	4 x 240	6 x M12	2 x M10
315LKC	K, M	D, E	2-4	370	D	-	2 x M63x1,5	2 x M63	2 x 240	6 x M12	2 x M10
315LKC	G, K, M	D, E	6-8	370	D	-	2 x M63x1,5	2 x M63	2 x 240	6 x M12	2 x M10
355SM_, ML_	R	D, E	2-6	750	E	-	2 x M75x1,5	1 x M75	4 x 240	6 x M12	2 x M10
355LK_	R	D, E	2-6	750	E	E-2D	4 x M75x1,5	3 x M75	4 x 240	6 x M12	2 x M10
355SMA	G, K, M	D	2-4	750	E	-	2 x M75x1,5	1 x M75	4 x 240	6 x M12	2 x M10
355SMA	G, K, M	E	2-4	370	D	-	2 x M63x1,5	2 x M63	2 x 240	6 x M12	2 x M10
355SMA	G	D, E	6	370	D	-	2 x M63x1,5	2 x M63	2 x 240	6 x M12	2 x M10
355SMA	G, K	D, E	8	370	D	-	2 x M63x1,5	2 x M63	2 x 240	6 x M12	2 x M10

Shaft height	Product design code	Voltage code	Pole number	Terminal box type	Size of gland plate opening in the terminal box	45° angle adapter	Amount and size of thread	Plugged holes	Max, connectable core cross section mm ² / phase	Number and size of terminal bolts	Earthing in the main terminal box
355SMB	K	D	2-4	750	E	-	2 x M75x1,5	1 x M75	4 x 240	6 x M12	2 x M10
355SMB	K	E	2-4	370	D	-	2 x M63x1,5	2 x M63	2 x 240	6 x M12	2 x M10
355SMB	G, M	D, E	2-4	750	E	-	2 x M75x1,5	1 x M75	4 x 240	6 x M12	2 x M10
355SMB	G, K, M	D, E	6	370	D	-	2 x M63x1,5	2 x M63	2 x 240	6 x M12	2 x M10
355SMB	G, K	D, E	8	370	D	-	2 x M63x1,5	2 x M63	2 x 240	6 x M12	2 x M10
355SMC	G, K, M	D, E	2-4	750	E	-	2 x M75x1,5	1 x M75	4 x 240	6 x M12	2 x M10
355SMC	G	D	6	750	E	-	2 x M75x1,5	1 x M75	4 x 240	6 x M12	2 x M10
355SMC	G	E	6	370	D	-	2 x M63x1,5	2 x M63	2 x 240	6 x M12	2 x M10
355SMC	K, M	D,E	6	370	D	-	2 x M63x1,5	2 x M63	2 x 240	6 x M12	2 x M10
355SMC	G, K	D, E	8	370	D	-	2 x M63x1,5	2 x M63	2 x 240	6 x M12	2 x M10
355MLA	G, K, M	D, E	2-4	750	E	-	2 x M75x1,5	1 x M75	4 x 240	6 x M12	2 x M10
355MLB	G	D	2	750	E	E-2D	4 x M75x1,5	3 x M75	4 x 240	6 x M12	2 x M10
355MLB	G	E	2	750	E	-	2 x M75x1,5	1 x M75	4 x 240	6 x M12	2 x M10
355MLB	K, M	D,E	2-4	750	E	-	2 x M75x1,5	1 x M75	4 x 240	6 x M12	2 x M10
355MLB	G	D	4	750	E	E-2D	4 x M75x1,5	3 x M75	4 x 240	6 x M12	2 x M10
355MLB	G	E	4	750	E	-	2 x M75x1,5	1 x M75	4 x 240	6 x M12	2 x M10
355MLB	K, M	D	6	750	E	-	2 x M75x1,5	1 x M75	4 x 240	6 x M12	2 x M10
355MLB	K, M	E	6	370	D	-	2 x M63x1,5	2 x M63	2 x 240	6 x M12	2 x M10
355MLB	G	D,E	6	750	E	-	2 x M75x1,5	1 x M75	4 x 240	6 x M12	2 x M10
355MLB	G, K	D	8	750	E	-	2 x M75x1,5	1 x M75	4 x 240	6 x M12	2 x M10
355MLB	G, K	E	8	370	D	-	2 x M63x1,5	2 x M63	2 x 240	6 x M12	2 x M10
355MLC	K, M	D	2	750	E	E-2D	4 x M75x1,5	3 x M75	4 x 240	6 x M12	2 x M10
355MLC	K, M	E	2-4	750	E	-	2 x M75x1,5	1 x M75	4 x 240	6 x M12	2 x M10
355MLC	K	D	4	750	E	E-2D	4 x M75x1,5	3 x M75	4 x 240	6 x M12	2 x M10
355MLC	M	D	4	750	E	-	2 x M75x1,5	1 x M75	4 x 240	6 x M12	2 x M10
355LKA	G, K, M	D	2	750	E	E-2D	4 x M75x1,5	3 x M75	4 x 240	6 x M12	2 x M10
355LKA	G, K, M	E	2	750	E	-	2 x M75x1,5	1 x M75	4 x 240	6 x M12	2 x M10
355LKA	G, K, M	D, E	4	750	E	E-2D	4 x M75x1,5	3 x M75	4 x 240	6 x M12	2 x M10
355LKA	M	D	6	750	E	-	2 x M75x1,5	1 x M75	4 x 240	6 x M12	2 x M10
355LKA	M	E	6	370	D	-	2 x M63x1,5	2 x M63	2 x 240	6 x M12	2 x M10
355LKA	G, K	D, E	6	750	E	-	2 x M75x1,5	1 x M75	4 x 240	6 x M12	2 x M10
355LKB	G, K, M	D	2	750	E	E-2D	4 x M75x1,5	3 x M75	4 x 240	6 x M12	2 x M10
355LKB	G, K, M	E	2	750	E	-	2 x M75x1,5	1 x M75	4 x 240	6 x M12	2 x M10
355LKB	G, K	D, E	4	750	E	E-2D	4 x M75x1,5	3 x M75	4 x 240	6 x M12	2 x M10

Shaft height	Product design code	Voltage code	Pole number	Terminal box type	Size of gland plate opening in the terminal box	45° angle adapter	Amount and size of thread	Plugged holes	Max, connectable core cross section mm ² / phase	Number and size of terminal bolts	Earthing in the main terminal box
355LKB	G, K, M	D, E	6	750	E	-	2 x M75x1,5	1 x M75	4 x 240	6 x M12	2 x M10
355LKB	G, K	D, E	8	750	E	-	2 x M75x1,5	1 x M75	4 x 240	6 x M12	2 x M10
355LKC	K	D, E	6	750	E	-	2 x M75x1,5	1 x M75	4 x 240	6 x M12	2 x M10
400L, LK	G, K, M, R	D, E	2-6	750	E	E-2D	4 x M75x1,5	3 x M75	4 x 240	6 x M12	2 x M10
400L, LK	G, K	D, E	8	750	E	-	2 x M75x1,5	1 x M75	4 x 240	6 x M12	2 x M10
450LA, LB, LC	R	D, E	2-6	1200	E	E-2D	4 x M75x1,5	3 x M75	6 x 240	6 x M12	4 x M12
450 LA, LB	G, K, M	D	2	1200	E	E-2D	4 x M75x1,5	3 x M75	6 x 240	6 x M12	4 x M12
450 LC	G, K, M	U	2	1200	E	E-2D	4 x M75x1,5	3 x M75	6 x 240	6 x M12	4 x M12
450LA, LB, LC	G, M	E	2	1200	E	E-2D	4 x M75x1,5	3 x M75	6 x 240	6 x M12	4 x M12
450LA, LB, LC	G, K	D	4	1200	E	E-2D	4 x M75x1,5	3 x M75	6 x 240	6 x M12	4 x M12
450LA, LB, LC	M	D, E	4	1200	E	E-2D	4 x M75x1,5	3 x M75	6 x 240	6 x M12	4 x M12
450LA	G, K	E	4	750	E	E-2D	4 x M75x1,5	3 x M75	4 x 240	6 x M12	2 x M10
450LB, LC	G, K	E	4	1200	E	E-2D	4 x M75x1,5	3 x M75	6 x 240	6 x M12	4 x M12
450LA	G, K, M	D, E	6	750	E	E-2D	4 x M75x1,5	3 x M75	4 x 240	6 x M12	2 x M10
450LB, LC	G, K, M	D, E	6	1200	E	E-2D	4 x M75x1,5	3 x M75	6 x 240	6 x M12	4 x M12
450LA, LB, LC	G, K	D, E	8	750	E	E-2D	4 x M75x1,5	3 x M75	4 x 240	6 x M12	2 x M10
450LD	K	D, E	8	750	E	E-2D	4 x M75x1,5	3 x M75	4 x 240	6 x M12	2 x M10
500 LA, LB, LC	M, R	Y, U, D, E	4-6	1200	E	E-2D	4 x M75x1,5	3 x M75	6 x 240	6 x M12	4 x M12
500 LB, LC	M	Y, U, D, E	8	1200	E	E-2D	4 x M75x1,5	3 x M75	6 x 240	6 x M12	4 x M12

Auxiliary cable entries	Pole number	Amount and size of threaded plugged holes	Max, connectable core cross section mm ² / phase
71-132	all	-	-
160-500	all	2x M20x1,5	1x 2,5

Terminal box

Terminal box dimensions

01 Terminal box type 63 and 160.

02 Terminal box types 210 and 370.

03 Terminal box type 750 + adapter.

04 Terminal box type 1200 + adapter.

For motor sizes 71–132 the terminal box is integrated in motor frame and the dimensions for terminal boxes can be found in the motor dimension drawings in ABB Library.

To match the correct terminal box with motor sizes 160–500, find the motor type and correspondent terminal box type on the previous page. The box types and their dimensions are presented on this page.

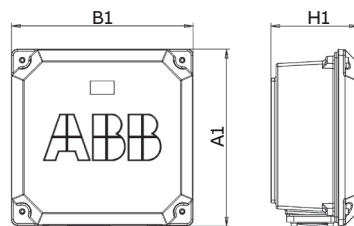

01

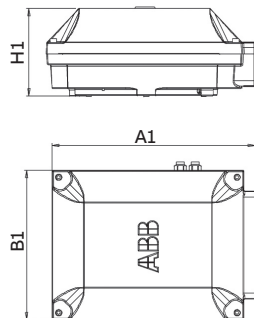

02

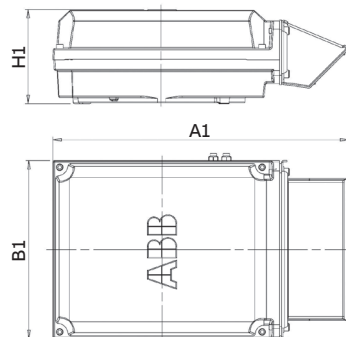

03

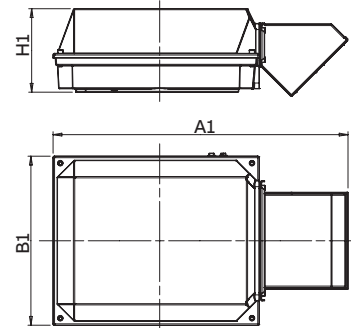

04

Terminal box types	A1	B1	H1	Gland plate opening
63	248	248	109	B
160	291	302	154	C
210	416	306	177	C
370	451	347	200	D
750 with E-D adapter	686	413	219	D
750 without E-D	523	413	219	E
750 with E-2D adapter	826	413	219	2xD
1200 with E-2D adapter	1000	578	285	2xD
1200 without E-2D adapter	697	578	285	E
1200 with E-2E adapter	1195	578	285	2xE
1200 with E-3D adapter	1250	578	285	3xD
2500	1046	726	495	4xE

Dimensions for terminal box inlets

Corresponds to motor sizes 160 and above

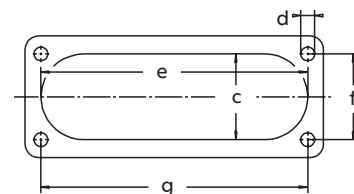

Flange opening	c	e	f	g	d
	mm	mm	mm	mm	thread type
B	31	120	30	120	M6
C ¹⁾	71	194	62	193	M6
C ²⁾	67	193	62	193	M8
D	100	300	80	292	M10
E	115	370	100	360	M12

Note! The C flange is different depending on frame size

¹⁾Frame sizes 200-225

²⁾Frame size 280

Terminal box

Cable glands

The motors are delivered as standard with plugged cable entries as described in the previous section. There is available a broad selection of different type of cable glands, which are suitable for different types of cable and outer diameter ranges.

Size of threaded opening for cable gland	Cable gland(s) nickel plated brass, variant code 230 or 731	EMC Cable gland(s) nickel-plated brass, variant code 704	Cable gland(s) plastic, variantcode 375 or 376
	Cable outer diameter, mm	Cable outer diameter, mm	Cable outer diameter, mm
M16 x 1.5	4-12	4-8	4-12
M20 x 1.5	4-12	4-12	4-12
M25 x 1.5	10-18	10-18	10-18
M32 x 1.5	14-24	14-24	14-24
M40 x 1.5	22-32	22-32	22-32
M50 x 1.5	26-35	26-35	26-35
M63 x 1.5 *)	35-45	35-45	35-45
M75 x 1.5	46-62	46-62	not available

Threaded openings for cable glands with NPT thread (variant code 730)

The standard delivery for the motors are provided with openings for cable glands with metric threads as listed in the section describing the standard terminal box. If NPT threads will be needed, the variant code 730 is to be ordered. Please check the variant code description for more information.

Motor frame size	Cable entries for auxiliaries	NPT plug
80-112	2 x 3/4"	2 x 3/4"
132	1 x 3/4"	1 x 3/4"
160-500	2 x 3/4"	2 x 3/4"

Gland plates with threaded openings for cable glands of nonstandard size

If the standard size of threaded openings for cable glands is not suitable then nonstandard size openings are also available, either by fitting the reducers to make the openings smaller or by increasing the amount or size of holes. The maximum possible size and amount for each gland plate size is listed below. Threaded openings of non-standard size can be ordered by using variant codes 554 and 727.

Gland plate size	Maximum amount and size of threaded holes
B	2 x M40
C	2 x M63
D	2 x M90 or 3 x M75
E	2 x M90 or 4 x M75

Terminal box

Terminal boxes and boards

—
01 Integrated terminal box for motor sizes 71–112. Tapped holes for cable entries.

02 Terminal board for motor sizes 90–112, IE2, and 90–100, IE3.

03 Terminal board for motor sizes 71–80.

04 Terminal board for motor sizes 112, IE3.

05 Integrated terminal box for motor sizes 132. Tapped holes for cable entries.

06 Terminal board for motor size 132.

07 Terminal box for motor sizes 160–250. Connection flanges with tapped cable entries.

08 Terminal board for motor sizes 160–250.

The pictures below show standard terminal boxes and the corresponding terminal boards for various motor sizes.

Motor sizes 71–112

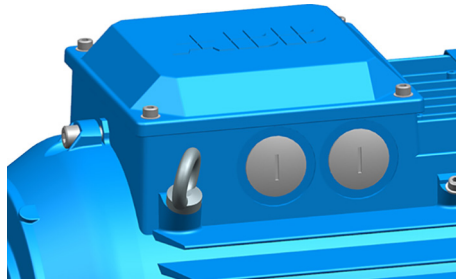

—
01

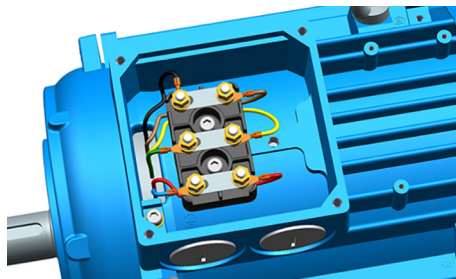

—
02

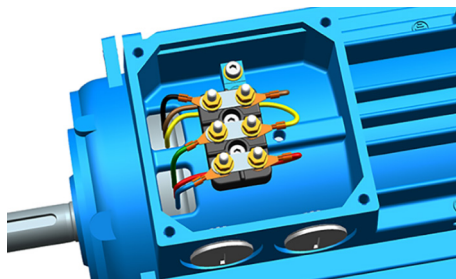

—
03

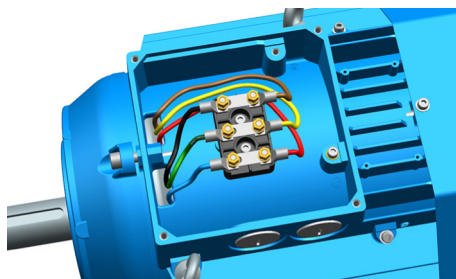

—
04

Motor size 132

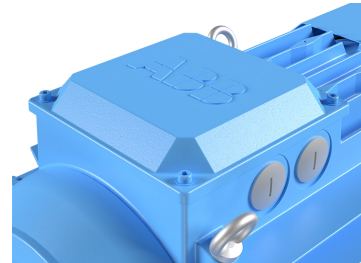

—
05



—
06

Motor sizes 160–250

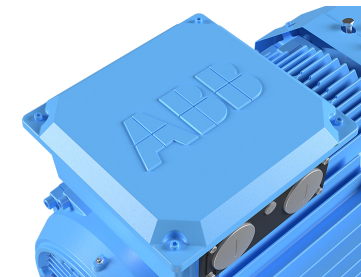

—
07



—
08

Motor sizes 280 - 315

—
09 Terminal box for motor sizes 280 - 315, except LKC. Connection flange with tapped cable entries

10 Terminal board for motor sizes 280 - 315, except LKC.

11 Terminal box for motor sizes 315LKC.

12 Terminal board for motor sizes 315 LKC.

13 Terminal box for motor sizes 355SM.

14 Terminal box with angle adapter for motor sizes 355ML - 450.

15 Terminal board for motor sizes 355 to 400.

16 Terminal board for motor size 450.

17 Terminal box for motor sizes 500.

18 Terminal board for motor sizes 500.

—
09

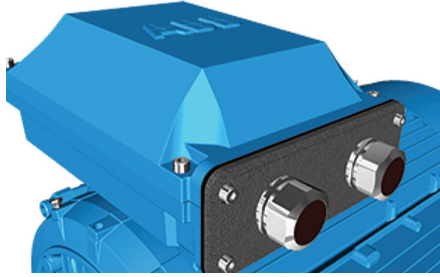

—
10

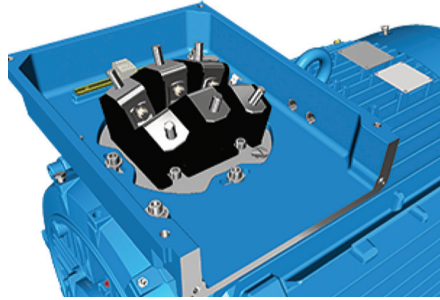

—
11



—
12

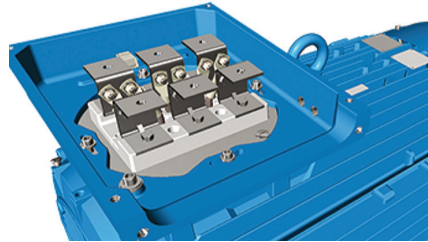

Motor sizes 355-450

—
13

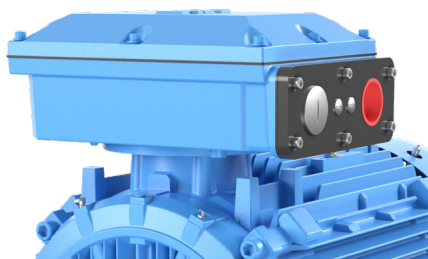

—
14

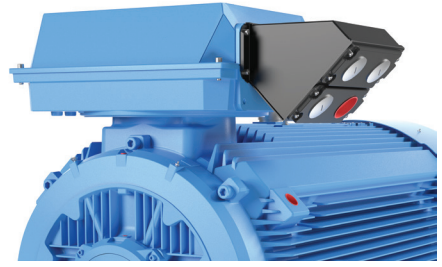

—
15

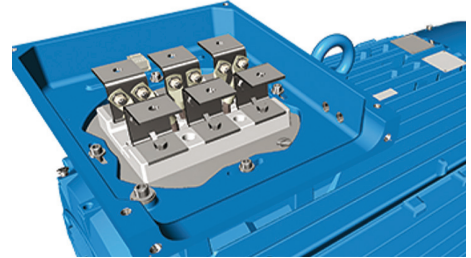

—
16

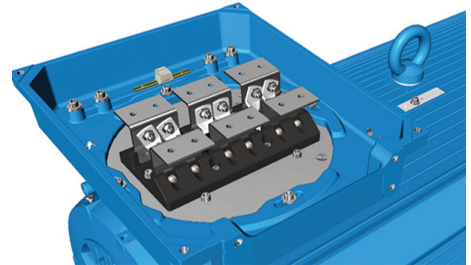

Motor size 500

—
17



—
18

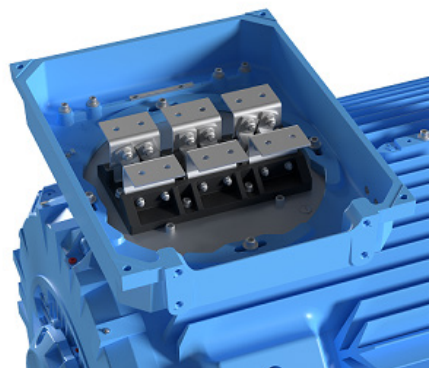

Terminal box

Terminal box alternatives

01 Main terminal box.

02 Adapters, Flange with glands; cable sealing end units.

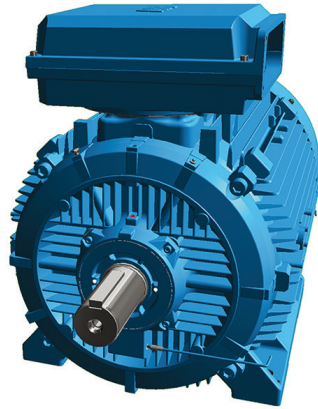

01

Adapters

There is a broad selection of cable termination accessories available to allow termination of one or several cables. The most common ones are explained below.

How to order

- Check first that the terminal box itself allows mounting of the desired cable and cores (refer to motor type and terminal box type cross reference on previous page)
- If very large cables are used it might be necessary to use a larger terminal box than standard. Select the right cable gland(s) or cable sealing end unit(s) that match outer diameter of the cable(s)
- Select appropriate adapter or flange
- Note that turning the terminal box to a non-standard position might limit the use of some adapters.

Ordering example

Motor Cables	200 kW, 4 pole, 400 V 50 Hz 2 pieces, outer diameter 58 mm, single core cross section 185 mm ² , clamping device needed, cables coming from below
	200 kW, 4 pole, 400 V 50 Hz 2 pieces, outer diameter 58 mm, single core cross section 185 mm ² , clamping device needed, cables coming from below
Motor	M3BP 315 MLA 4-pole, B3
Adapter	D-D - variant code 293
Cable sealing end unit	Variant code 278
Clamping	Variant code 231
Auxiliaries	Variant codes 380, 567, 568



02



Main terminal box and maximum single core cross-section

You can select one size larger than standard terminal box if a larger single cross-section is needed. The standard sizes of the main terminal box are listed in the following table. The terminal box is named according to its current-carrying capacity, from 120 to 1200. Check also the capacity of the cable entry to make sure that the cables fit. A larger terminal box can be ordered with variant code 019.

Standard terminal box	Large terminal box	Size of opening, large box	Max single cross-section mm ² / phase
120	210	B	1 x 70
210	370	C	2 x 240
370	750	D	2 x 300
750	1200	E	4 x 500
1200	-	-	-

Optional adapters

To allow easy termination of cables entering the terminal box from above or below, an angle adapter is recommended. These can be used to allow the mounting of several cable sealing end units or gland plates. For exact suitability on a certain motor size, refer to the 'terminal box opening' column in section Standard terminal box.

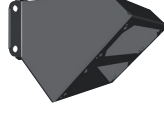
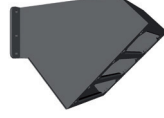
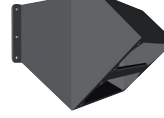
Adapater						
Variant code	292	293	294	295	296	444
Opening to terminal box	C	D	E	E	E	E
Flange or opening for end unit	C	D	D	2 x D	3 x D	2 x E
Material	Cast iron	Cast iron	Cast iron	Steel	Steel	Steel
Notes				Included as standard delivery for some types.	Only possible on type 1200 terminal box.	Only possible on type 1200 terminal box.

Cable sealing end units

As an alternative to flanges and cable glands, cable sealing end units can be used. These allow more space for spreading the cores for easy termination.

Cable sealing end units have rubber-sealed entries for one of two main cables. In addition, there are two plugged M20 holes for auxiliary cables.

Please note that the table below is only for guidance. Due to the large amount of combinations possible between terminal box sizes, end units and adapters, not all possible combinations can be described. Please contact your ABB sales office for more detailed information.

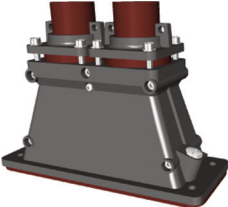
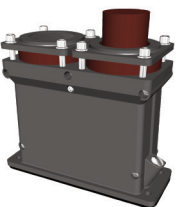
	Medium	Large
End unit		
Variant code	278	279
Opening to terminal box or to adapter	D	D
Cable outer diameter	1–2 cables, 48–60 mm	1–2 cables, 60–80 mm
Cable entry for auxiliary cable	2 x M20 plugged holes	2 x M20 plugged holes
Additional optional variants	EMC cable gland (704)	EMC cable gland (704)

Auxiliary terminal box

You can equip motors with one or several auxiliary terminal boxes for connection of auxiliaries like heaters or temperature detectors. The standard auxiliary terminal box material for motor sizes 280–500 is aluminum. For 280–500, cast iron as box material is also available as an option.

Connection terminals are of spring-loaded type for quick and easy connection. These are suitable for up to 2.5 mm² wires. Auxiliary terminal boxes for 280–500 are equipped with an earthing terminal. The first auxiliary terminal box is located on the right-hand side at D-end as standard.

The standard cable entry size is M20 for the aluminum box and M16 for the cast iron box, and the number of entries depends on the terminal box type and the number of selected auxiliaries.

Related variant codes

380	Separate terminal box for temperature detectors, standard material
418	Separate terminal box for auxiliaries, standard material
567	Separate terminal box material: cast iron
568	Separate terminal box for heating elements, standard material
569	Separate terminal box for brake

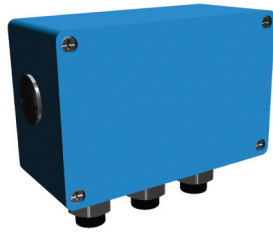

Small auxiliary aluminum terminal box for motor sizes 280–500 (variant codes 418, 568, 380, 569) The size of terminal box ordered with these codes depends on the number of accessories ordered. 80 x 125 mm, max 12 strips. Earthing size M4

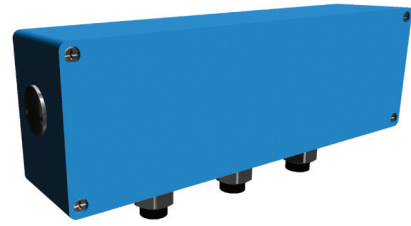

Large auxiliary aluminum terminal box for motor sizes 280–500. The size of terminal box ordered with these codes depends on the number of accessories ordered. 80 x 250 mm, max 30 strips. Earthing size M4



Frame size for motor sizes 280–500 (variant code 567): 208 x 180 mm, max 30 strips. Earthing size M6

Dimension drawings

Process performance IE5 cast iron motors

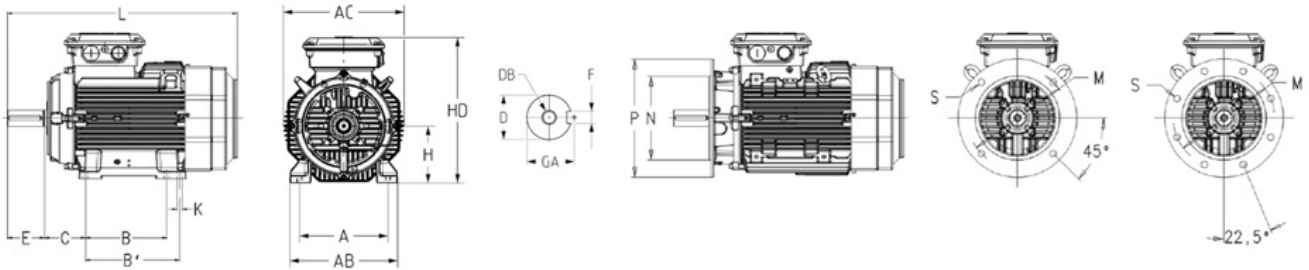

Motor size	IM1001, IMB3 and IM3001, IMB5										IM1001, IMB3				IM B5 (IM3001)												
	D		DB		GA		F		E		L max		A	AB	AC	B	B1	C	HD	HD	HD	HD	K	M	N	P	S
	2	4-8	2	4-8	2	4-8	2	4-8	2	4-8	2	4-8						¹⁾	²⁾	³⁾	⁴⁾						
280 SM_	65	75	M20	M20	69	79,5	18	20	140	140	1088	1088	457	530	577	368	419	190	762	-	-	-	24	500	450	550	18
280 ML_	65	75	M20	M20	69	79,5	18	20	140	140	1190	1190	457	530	577	419	457	190	762	-	-	-	24	500	450	550	18
315 SM_	65	80	M20	M20	69	85	18	22	140	170	1172	1202	508	590	654	406	457	216	-	852	-	-	28	600	550	660	23
315 ML_	65	90	M20	M24	69	95	18	25	140	170	1283	1313	508	590	654	457	508	216	-	852	-	-	28	600	550	660	23
315 LK_	65	90	M20	M24	69	95	18	25	140	170	1489	1519	508	590	660	508	560	216	-	854	-	-	28	600	550	660	23
355 SM_	70	100	M20	M24	74,5	106	20	28	140	210	1409	1479	610	700	746	500	560	254	-	-	958	-	35	740	680	800	23
355 ML_	70	100	M20	M24	74,5	106	20	28	140	210	1514	1584	610	700	746	560	630	254	-	-	958	-	35	740	680	800	23
355 LK_	70	100	M20	M24	74,5	106	20	28	140	210	1764	1834	610	700	746	630	710	254	-	-	958	-	35	740	680	800	23
400 L_	80	110	M20	M24	85	116	22	28	170	210	1851	1891	710	840	834	900	1000	224	-	-	1045	-	35	940	880	1000	28
450 L_	80	120	M20	M24	85	127	22	32	170	210	2147	2187	800	950	966	1000	1120	250	-	-	-	1293	42	1080	1000	1150	28
500 L_	-	140	M36	M36	-	148	-	36	-	250	-	2426	900	1050	1081	1250	1410	280	-	-	-	1395	42	1180	1120	1250	28

¹⁾Terminal box 210

²⁾Terminal box 370

³⁾Terminal box 750

⁴⁾Terminal box 1200

Tolerances	
A, B	± 0.8
C, CA	± 0.8
D	ISO k6 < Ø 50 mm
	ISO m6 > Ø 50 mm
F	ISO h9
H	+ 0 -1
N	ISO js6

Dimension drawings

Process performance IE4 cast iron motors

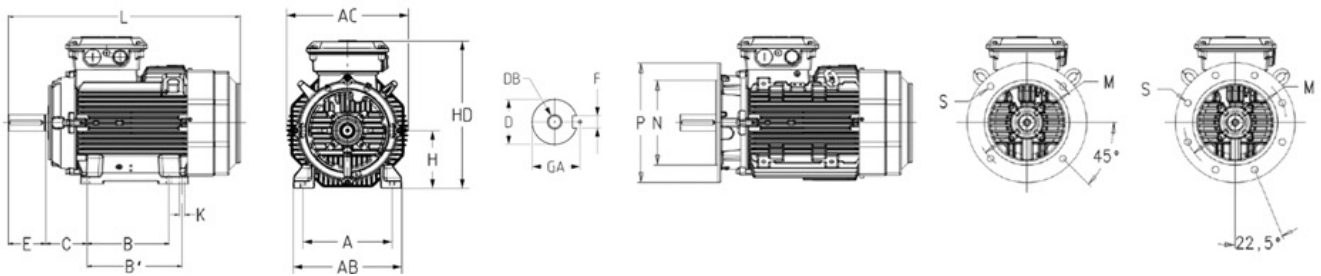

Motor size	IM1001, IMB3 and IM3001, IMB5										IM1001, IMB3							IM B5 (IM3001)													
	D		DB		GA		F		E		L max		A	AB	AC	B	B'	C	HD	HD	HD	HD	HD	HD	HD	K	M	N	P	S	
	2	4-8	2	4-8	2	4-8	2	4-8	2	4-8	2	4-8							1)	2)	3)	4)	5)	6)	7)						
100 2-6	28	28	M10	M10	31	31	8	8	60	60	524	524	160	200	206	140	160	63	251	-	-	-	-	-	-	12	215	180	250	15	
112 2-6	28	28	M10	M10	31	31	8	8	60	60	513	513	190	230	239	140	-	70	263	-	-	-	-	-	-	12	215	180	250	15	
132 2-6	38	38	M12	M12	41	41	10	10	80	80	624	624	216	262	271	140	178	89	303	-	-	-	-	-	-	12	265	230	300	15	
160 MLA 2-6,	42	42	M16	M16	45	45	12	12	110	110	681	681	254	310	338	210	254	108	-	421	-	-	-	-	-	14,5	300	250	350	19	
MLB 2-4,																															
MLC 2																															
160 MLB 6,	-	42	-	M16	-	45	-	12	-	110	-	721	254	310	338	210	254	108	-	421	-	-	-	-	-	14,5	300	250	350	19	
MLC 4																															
180 MLA 2	48	-	M16	-	51,5	-	14	-	110	-	726	-	279	340	381	241	279	121	-	461	-	-	-	-	-	14,5	300	250	350	19	
180 MLA 6,	-	48	-	M16	-	51,5	-	14	-	110	-	766	279	340	381	241	279	121	-	461	-	-	-	-	-	14,5	300	250	350	19	
MLB 4, MLC 4																															
200 MLA 2-6,	55	55	M20	M20	59	59	16	16	110	110	821	821	318	378	413	267	305	133	-	-	528	-	-	-	-	18,5	350	300	400	19	
MLB 2, 6																															
200 MLC 6	-	55	-	M20	-	59	-	16	-	110	-	879	318	378	413	267	305	133	-	-	528	-	-	-	-	18,5	350	300	400	19	
225SMA 2-6,	55	60	M20	M20	59	64	16	18	110	140	849	879	356	435	460	286	311	149	-	-	574	-	-	-	-	18,5	400	350	450	19	
SMB 4																															
225SMC 4	-	60	-	M20	-	64	-	18	-	140	-	919	356	435	460	286	311	149	-	-	574	-	-	-	-	18,5	400	350	450	19	
250	60	65	M20	M20	64	69	18	18	140	140	884	884	406	480	508	311	349	168	-	-	626	-	-	-	-	24	500	450	550	19	
280SM	65	75	M20	M20	69	79,5	18	20	140	140	1088	1088	457	530	577	368	419	190	-	-	-	762	-	-	-	24	500	450	550	18	
280ML	65	75	M20	M20	69	79,5	18	20	140	140	1190	1190	457	530	577	419	457	190	-	-	-	762	785	-	-	24	500	450	550	15	
315SM	65	80	M20	M20	69	85	18	22	140	170	1172	1202	508	590	654	406	457	216	-	-	-	-	852	-	-	28	600	550	660	23	
315ML	65	90	M20	M24	69	95	18	25	140	170	1283	1313	508	590	654	457	508	216	-	-	-	-	852	-	-	28	600	550	660	23	
315LK	65	90	M20	M24	69	95	18	25	140	170	1489	1519	508	590	660	508	560	216	-	-	-	-	854	880	-	28	600	550	660	23	
355SM	70	100	M20	M24	74,5	106	20	28	140	210	1409	1479	610	700	746	500	560	254	-	-	-	-	944	958	-	35	740	680	800	23	
355ML	70	100	M20	M24	74,5	106	20	28	140	210	1514	1584	610	700	746	560	630	254	-	-	-	-	944	958	-	35	740	680	800	23	
355LK	70	100	M20	M24	74,5	106	20	28	140	210	1764	1834	610	700	746	630	710	254	-	-	-	-	944	958	-	35	740	680	800	23	
400L	80	110	M20	M24	85	126	22	28	170	210	1851	1891	710	840	834	900	1000	224	-	-	-	-	1045	-	-	35	940	880	1000	28	
400LK	80	100	M20	M24	85	106	22	28	170	210	1851	1891	686	840	834	710	800	280	-	-	-	-	1045	-	-	35	740	680	800	24	
450L	80	120	M20	M24	85	127	22	32	170	210	2027	2187	800	950	966	1000	1120	250	-	-	-	-	1169	1231	42	1080	1000	1150	28		
500L	-	140	M36	M36	-	148	-	36	-	250	-	2426	900	1050	1081	1250	1410	280	-	-	-	-	-	-	-	139,5	42	1180	1120	1250	28

- 1) Integrated
- 2) Terminal box 63.
- 3) Terminal box 160.
- 3) Terminal box 210.
- 5) Terminal box 370.
- 6) Terminal box 750.
- 7) Terminal box 1200.

IMB14 (IM3601)

Motor size	M	N	P	S	T
100	130	110	160	8	3.5
112	130	110	160	8	3.5
132	165	130	200	10	3.5

Tolerances	71-250	280-500
A, B	± 0,4	± 0,8
C, CA	± 0,8	± 0,8
D	ISO k6 < Ø 50 mm	ISO k6 < Ø 50 mm
	ISO m6 > Ø 50 mm	ISO m6 > Ø 50 mm
F	ISO h9	ISO h9
H	+ 0 -0,5	+ 0 -0,5
N	ISO j6	ISO j6

The table gives the main dimension in mm. For detailed drawings please see our web pages www.abb.com/motors&generators.

Dimension drawings

Process performance IE3 cast iron motors

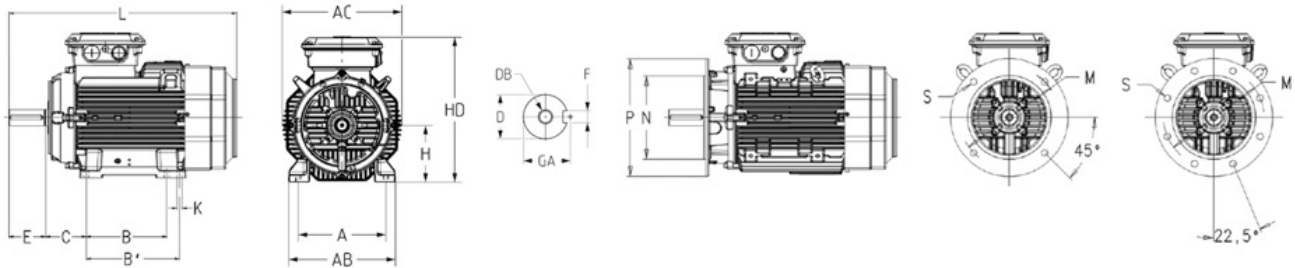

Motor size	IM1001, IMB3 and IM3001, IMB5										IM1001, IMB3					IM B5 (IM3001)								
	D		DB		GA		F		E		L		A	AB	AC	B	B'	C	HD	K	M	N	P	S
	2	4-8	2	4-8	2	4-8	2	4-8	2	4-8	2	4-8	max		max									
71	14	14	M5	M5	16	16	5	5	30	30	264	264	112	136	139	90	110	45	178	7	130	110	160	10
80M_	19	19	M6	M6	21,5	21,5	6	6	40	40	321	321	125	154	157	100	125	50	194	10	165	130	200	12
80ML_	19	19	M6	M6	21,5	21,5	6	6	40	40	353	353	125	154	157	100	136	50	194	10	165	130	200	12
90SL_	24	24	M8	M8	27	27	8	8	50	50	356	356	140	170	177	100	125	56	218	10	165	130	200	12
90L_	24	24	M8	M8	27	27	8	8	50	50	390	390	140	170	177	100	125	56	218	10	165	130	200	12
100LK_	28	28	M10	M10	31	31	8	8	60	60	435	435	160	200	197	140	160	63	247	12	215	180	250	15
112	28	28	M10	M10	31	31	8	8	60	60	442	442	190	230	197	140	172	70	258	12	215	180	250	15
132	38	38	M12	M12	41	41	10	10	80	80	533	533	216	262	271	140	178	89	300	12	265	230	300	15
160 ¹⁾	42	42	M16	M16	45	45	12	12	110	110	584	584	254	310	338	210	254	108	421	14,5	300	250	350	19
160 ²⁾	42	42	M16	M16	45	45	12	12	110	110	681	681	254	310	338	210	254	108	421	14,5	300	250	350	19
180	48	48	M16	M16	51,5	51,5	14	14	110	110	726	726	279	340	381	241	279	121	461	14,5	300	250	350	19
200	55	55	M20	M20	59	59	16	16	110	110	821	821	318	378	413	267	305	133	528	18,5	350	300	400	19
225	55	60	M20	M20	59	64	16	18	110	140	849	879	356	435	460	286	311	149	573	18,5	400	350	450	19
250	60	65	M20	M20	64	69	18	18	140	140	884	884	406	480	508	311	349	168	626	24	500	450	550	19
280SM_	65	75	M20	M20	69	79,5	18	20	140	140	1088	1088	457	530	577	368	419	190	762	24	500	450	550	18,5
280ML_	65	75	M20	M20	69	79,5	18	20	140	140	1190	1190	457	530	577	368	419	190	785	24	500	450	550	18,5
315SM_	65	80	M20	M20	69	85	18	22	140	170	1172	1202	508	590	654	406	457	216	852	30	600	550	660	23
315ML_	65	90	M20	M24	69	95	18	25	140	170	1283	1313	508	590	654	457	508	216	852	30	600	550	660	23
315LK_	65	90	M20	M24	69	95	18	25	140	170	1491	1521	508	590	654	457	508	216	880	30	600	550	660	23
355SM_	70	100	M20	M24	74,5	106	20	28	140	210	1409	1479	610	700	746	500	560	254	958	35	740	680	800	23
355ML_	70	100	M20	M24	74,5	106	20	28	140	210	1514	1584	610	700	746	560	630	254	958	35	740	680	800	23
355LK_	70	100	M20	M24	74,5	106	20	28	140	210	1764	1834	610	700	746	630	710	254	958	35	740	680	800	23
400L_	80	110	M20	M24	85	126	22	28	170	210	1851	1891	710	840	834	900	1000	224	1045	35	940	880	1000	28
400LK_	80	100	M20	M24	85	106	22	28	170	210	1851	1891	686	840	834	710	800	280	1045	35	740	680	800	24
450	80	120	M20	M24	85	127	22	32	170	210	2027	2187	800	950	966	1000	1120	250	1231	42	1080	1000	1150	28

¹⁾ MLA 2, MLA 8, MLB 8

²⁾ Others except MLA 2, MLA 8, MLB 8

IMB14 (IM3601)

Motor size	M	N	P	S	T
71	85	70	105	6	2.5
80	100	80	120	6	3
90	115	95	140	8	3
100	130	110	160	8	3.5
112	130	110	160	8	3.5
132	165	130	200	10	3.5

Tolerances	71-250	280-500
A, B	± 0,4	± 0,8
C, CA	± 0,8	± 0,8
D	ISO k6 < Ø 50 mm	ISO k6 < Ø 50 mm
	ISO m6 > Ø 50 mm	ISO m6 > Ø 50 mm
F	ISO h9	ISO h9
H	+ 0 -0,5	+ 0 -0,5
N	ISO j6	ISO j6

The table gives the main dimension in mm. For detailed drawings please see our web pages www.abb.com/motors&generators.

Dimension drawings

Process performance IE2 cast iron motors

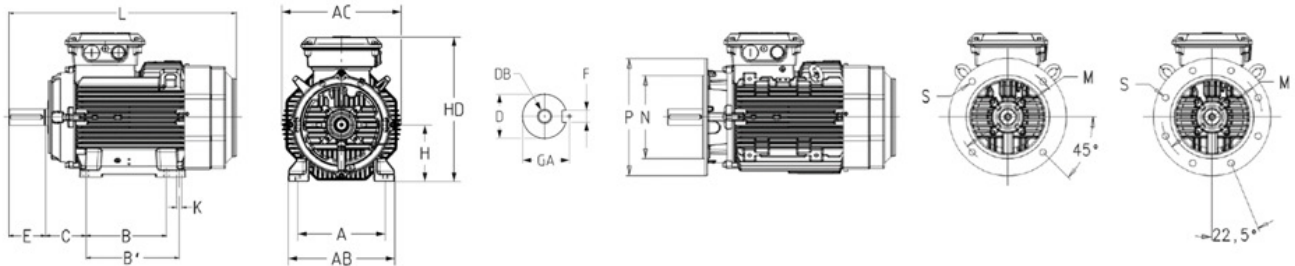

Motor size	IM1001, IMB3 and IM3001, IMB5										IM1001, IMB3					IM B5 (IM3001)								
	D		DB		GA		F		E		L		A	AB	AC	B	B'	C	HD	K	M	N	P	S
	2	4-8	2	4-8	2	4-8	2	4-8	2	4-8	2	4-8	max											
71	14	14	M5	M5	16	16	5	5	30	30	264	264	112	136	139	90	110	45	178	7	130	110	160	10
80M_	19	19	M6	M6	21,5	21,5	6	6	40	40	321	321	125	154	157	100	125	50	194	10	165	130	200	12
90SL_	24	24	M8	M8	27	27	8	8	50	50	356	356	140	170	177	100	125	56	218	10	165	130	200	12
100L_	28	28	M10	M10	31	31	8	8	60	60	381	381	160	200	197	140	-	63	247	12	215	180	250	15
100ML_	28	28	M10	M10	31	31	8	8	60	60	403	403	160	200	197	140	172	63	247	12	215	180	250	15
112	28	28	M10	M10	31	31	8	8	60	60	403	403	190	230	197	140	172	70	259	12	215	180	250	15
132	38	38	M12	M12	41	41	10	10	80	80	533	533	216	262	271	140	178	89	300	12	265	230	300	15
160 ¹⁾	42	42	M16	M16	45	45	12	12	110	110	584	584	254	310	338	210	254	108	421	14,5	300	250	350	19
160 ²⁾	42	42	M16	M16	45	45	12	12	110	110	681	681	254	310	338	210	254	108	421	14,5	300	250	350	19
180	48	48	M16	M16	51,5	51,5	14	14	110	110	726	726	279	340	381	241	279	121	461	14,5	300	250	350	19
200	55	55	M20	M20	59	59	16	16	110	110	821	821	318	378	413	267	305	133	528	18,5	350	300	400	19
225	55	60	M20	M20	59	64	16	18	110	140	849	879	356	435	460	286	311	149	573	18,5	400	350	450	19
250	60	65	M20	M20	64	69	18	18	140	140	884	884	406	480	508	311	349	168	626	24	500	450	550	19
280SM_	65	75	M20	M20	69	79,5	18	20	140	140	1088	1088	457	530	577	368	419	190	762	24	500	450	550	18,5
280ML_	65	75	M20	M20	69	79,5	18	20	140	140	1190	1190	457	530	577	368	419	190	785	24	500	450	550	18,5
315SM_	65	80	M20	M20	69	85	18	22	140	170	1172	1202	508	590	654	406	457	216	852	30	600	550	660	23
315ML_	65	90	M20	M24	69	95	18	25	140	170	1283	1313	508	590	654	457	508	216	852	30	600	550	660	23
315LK_	65	90	M20	M24	69	95	18	25	140	170	1491	1521	508	590	654	457	508	216	880	30	600	550	660	23
355SM_	70	100	M20	M24	74,5	106	20	28	140	210	1409	1479	610	700	746	500	560	254	958	35	740	680	800	23
355ML_	70	100	M20	M24	74,5	106	20	28	140	210	1514	1584	610	700	746	560	630	254	958	35	740	680	800	23
355LK_	70	100	M20	M24	74,5	106	20	28	140	210	1764	1834	610	700	746	630	710	254	958	35	740	680	800	23
400L_	80	110	M20	M24	85	126	22	28	170	210	1851	1891	710	840	834	900	1000	224	1045	35	940	880	1000	28
400LK_	80	100	M20	M24	85	106	22	28	170	210	1851	1891	686	840	834	710	800	280	1045	35	740	680	800	24
450	80	120	M20	M24	85	127	22	32	170	210	2027	2187	800	950	966	1000	1120	250	1231	42	1080	1000	1150	28

¹⁾ MLA2-8, MLB 2, MLB 8

²⁾ MLB 4-6, MLC 2-8, MLD 2-4, MLE

IMB14 (IM3601)

Motor size	M	N	P	S	T
71	85	70	105	6	2.5
80	100	80	120	6	3
90	115	95	140	8	3
100	130	110	160	8	3.5
112	130	110	160	8	3.5
132	165	130	200	10	3.5

Tolerances	71-250	280-500
A, B	± 0,4	± 0,8
C, CA	± 0,8	± 0,8
D	ISO k6 < Ø 50 mm ISO m6 > Ø 50 mm	ISO k6 < Ø 50 mm ISO m6 > Ø 50 mm
F	ISO h9	ISO h9
H	+ 0 -0,5	+ 0 -0,5
N	ISO j6	ISO j6

Accessories

Built-in brake (variant code 412)

Brake design

Electromagnetic disc brakes are applied by the action of a set of springs and are released when voltage is applied to the brake coil.

This means that the motor will brake automatically in case of any voltage failure, as significant safety feature. The brake is always functional, irrespective of the mounting position of the brake motor.

Detailed view

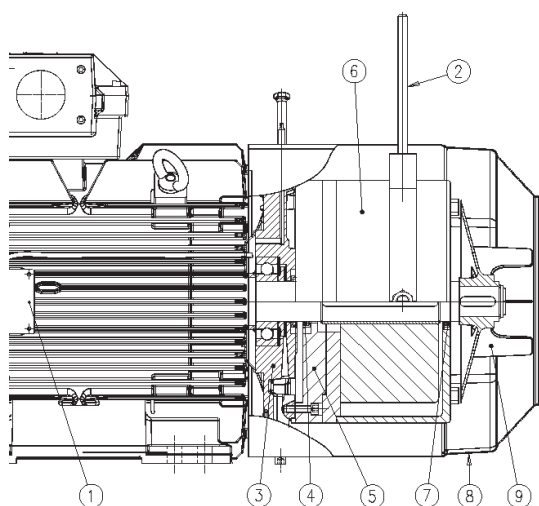

- 1 Connection box, (with rectifier, optional)
- 2 Manual release (optional)
- 3 Modified N-end shield
- 4 V-ring seal
- 5 Adapter flange for brake
- 6 Brake
- 7 V-ring seal
- 8 Fan cover
- 9 Fan

Brake disc

The brake linings are made of asbestos-free material. The linings are highly resistant to wear and have excellent thermal conductivity, providing consistent performance also in high temperatures.

The brake disc withstands a large number of braking instances and is insensitive to dust and moisture.

Note that changing from a used to a new disc will result in a different braking torque.

Replacing the brake disc

The brake disc must be replaced when the minimum permissible lining thickness has been reached. For minimum lining thickness, refer to the brake manufacturer's catalog.

Rectifier

Rectifier is a device for DC brake applications. It is highly resistant to temperature changes as well as to voltage peaks and has additional protection for the auxiliary contact of the contactor. Thanks to its compact design, it can be placed inside the motor's terminal box. Rectifier is an optional element.

Torque adjustment

Reducing the torque of the brake is possible with most brake types. Refer to the brake manufacturer's catalog or contact ABB for more information.

Manual release

Manual release bolts are provided as standard. A manual release handle is an optional element. Manual release overrides the action of brake springs as long as it is applied.

Though the manual release handle is optionally available for all motor sizes, it cannot be used in combination with the Pintsch Bamag brake type SFB.

Brake rating plates

The brake comes with two rating plates, one attached to the brake itself and another delivered loose, together with the motor. Variant code 412 is marked on the motor's rating plate (if it is listed among the five first codes on the motor order).

—
01 Foot-mounted: IM B3 (IM1001), IM B6 (IM 1051), IM B7 (IM1061), IM B8 (IM 1071), IM V5 (IM 1011), IM V6 (IM 1031).

02 Flange-mounted: IM B5 (IM 3001), IM V1 (IM 3011), IM V3 (IM 3031), IM B14 (IM 3601), IM V18 (IM 3611), IM V19 (IM 3631).

03 Foot- and flange-mounted: IM B35 (IM 2001), IM V15 (IM 2011), IM V36 (IM 2031).

Available brake types

Motors can be fitted with recommended brakes from either Pintsch Bamag or Stromag, as seen in the tables below. Other brakes can be provided on request.

Pintsch & Bamag, type KFB, IP 67, 110 V DC Electromagnetic Double-Disc Spring-Applied Brake

Brake type	Brake torque Nm	For motor size
KFB 10	100	160
KFB 16	160	160–180
KFB 25	250	180–225
KFB 40	400	200–250
KFB 63	630	225–280
KFB 1000	1000	280–315
KFB 1600	1600	315–355
On request		355–450

Pintsch & Bamag, type SFB, IP 67, 110 V DC Electromagnetic Double-Disc Spring-Applied Brake

Brake type	Brake torque Nm	For motor size
SFB 16	160	200–225
SFB 25	250	200–225
SFB 40	400	225–250
SFB 63	630	250
SFB 100	1000	280–315
SFB 160	1600	315–355
SFB 250	2500	355–400
SFB 400	4000	400
On request		450

Options for the brake

On new manufacture only:

- Hand release (not possible for Pintsch Bamag brake type SFB)
- Rectifier
- Micro switch
- Proximity switch (not possible for Stromag brake)
- Standstill heater

On request:

- Special brake voltage
- Raised brake torque
- Combination with brake, separate cooling fan and/or tacho
- For other variants, please contact ABB

Dimensions of brake motor

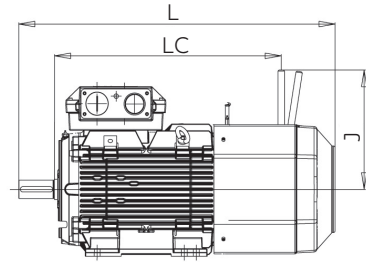

—
01

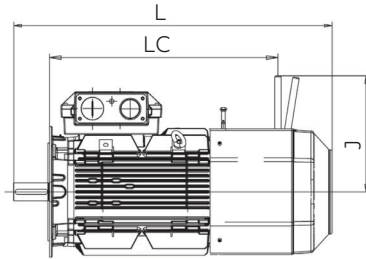

—
02

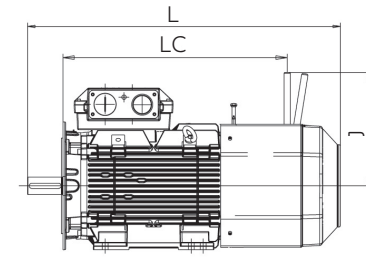

—
03

Motor size	Poles	Foot-mounted			Flange-mounted			Foot- and flange-mounted		
		L	LC	J	L	LC	J	L	LC	J
160 ¹⁾	2-8	773	511	372	773	511	372	773	511	372
160 ²⁾	2-8	871	608	372	871	608	372	871	608	372
180	2-8	935	687	372	935	687	372	935	687	372
200	2-8	1011	695	460	1011	695	460	1011	695	460
225	2-8	1085	729	460	1085	729	460	1085	729	460
225	4-8	1115	729	460	1105	729	460	1115	729	460
250	2-8	1119	755	460	1119	755	460	1119	755	460

¹⁾ MLA-2, MLB-2, MLC-2, MLA-4, MLA-6, MLA-8 and MLB-8 -poles

²⁾ MLD-2, MLE-2, MLB-4, MLC-4, MLD-4, MLB-6, MLC-6 and MLC-8 -poles

Motor sizes 280 to 450 on request. Other dimensions same as Process performance cast iron motors sizes 180 to 250

Accessories

Separate cooling

Axial fan, N-end

Fan motors with an axial fan are available for motor sizes 71–500 and can be ordered with variant code 183.

The fan motor types, and more detailed technical information can be found in the variant code description for code 183.

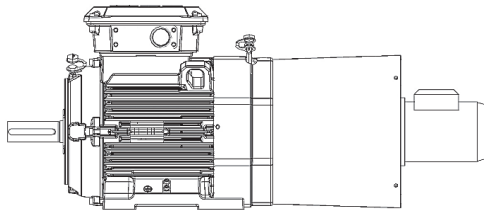

Fan on top, N-end

The non-axial fan available for motor sizes 280 and above is a Ziehl-Abegg fan with an integrated motor. This cooling option is suited for 400 V, 50 Hz networks and can be ordered with variant code 422. More detailed technical data can be found in the variant code description for code 422.

Special motor and fan on top, N-end

A special ABB fan motor type is available for motor sizes 280 and above. It is suited for environments where IP 65 is the required IP class or where the input voltage must be other than 360–420 V (50 Hz).

The centrifugal impeller used in the fan is a Ziehl-Abegg impeller. This type of cooling can be ordered with variant code 514 and more detailed information can be found in the variant code description.

Accessories

Silencer for motor sizes 280–450

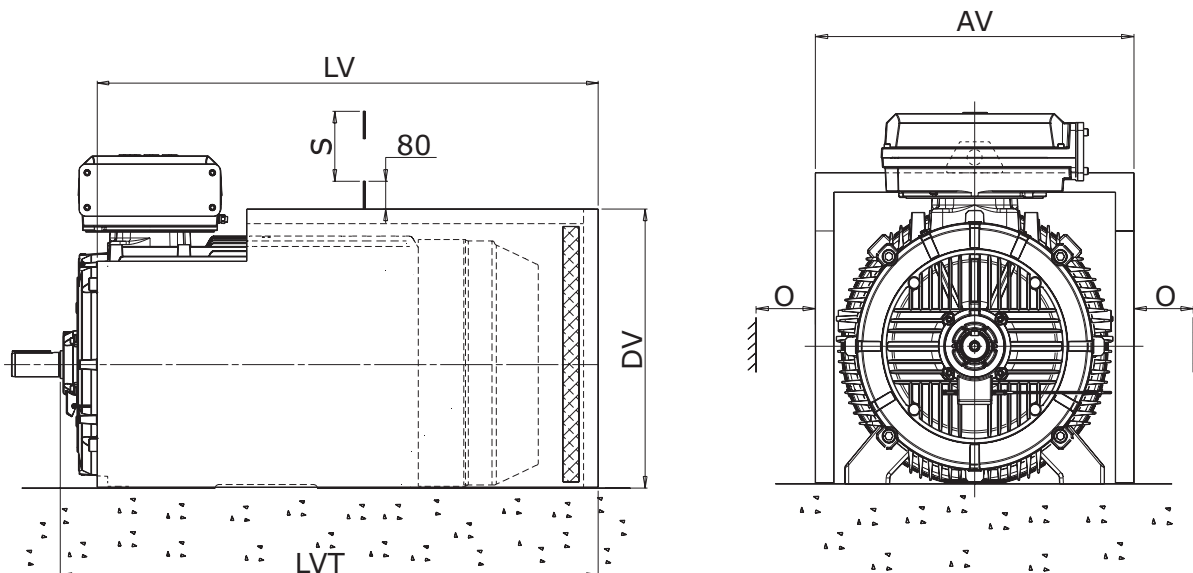

Both foot-mounted and flange-mounted motors can be fitted with a silencer to reduce noise level by about 5–6 dB(A). The silencer is painted blue and made of 2 mm steel sheet. The sound absorbing material is 40 mm thick polyurethane foam. On the rim there is a rubber strip for sealing on the floor. The silencer fits loosely over the motor.

The variant code for ordering a silencer is 055.

Motor size	AV	LV	LVT	DV	O ¹⁾	S ²⁾	Weight kg
280 SM_	681	1010	1090	616	50	762	38
315 SM_	760	1094	1191	697	60	852	47
315 ML_	760	1205	1302	697	60	852	51
315 LK_	760	1411	1508	697	60	852	58
355 SM_	850	1335	1441	777	65	958	62
355 ML_	850	1440	1546	777	65	958	67
355 LK_	850	1690	1796	777	65	958	77
400 L_	938	1750	1873	866	75	1045	88
400 LK_	938	1750	1873	866	75	1045	88
450 L_	1050	2110	2230	990	80	1045	120

¹⁾ Clearance for motor cooling.

²⁾ Clearance for removal of silencer.

Note: The dimensions are only valid for standard foot-mounted motors.

Accessories

Slide rails for motor sizes 160–250

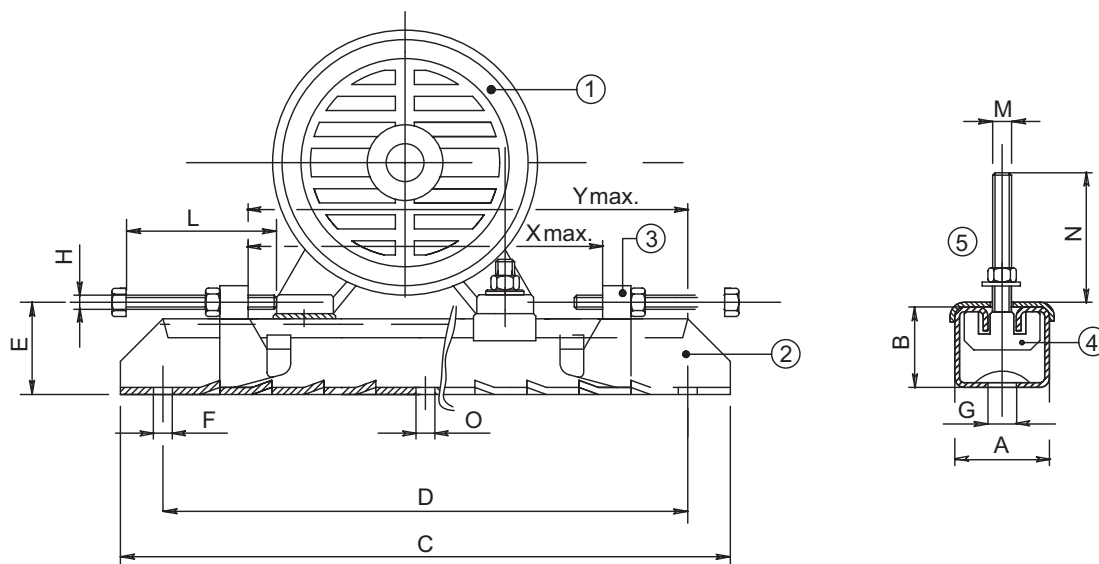

1 Motor 2 Rail 3 Movable adjusting bolt 4 Fixing bolt, motor 5 Plate

A set of slide rails includes two complete rails with screws for mounting the motor on the rails. Screws for mounting the rails on the foundation are not included. Slide rails have unmachined lower surfaces and should, before tightening down, be supported in a suitable manner. Slide rails can be ordered with article numbers shown in the table.

Motor size	Type	Article no.	A	B	C	D	E	F	G	H	L	M	N	O	Xmax	Ymax	Weight / rail kg
Frame sizes 71 to 132 on request																	
160–180	TT180/12	-14	75	42	700	630	57	17	26	M12	120	M12	50	–	520	580	12.0
200–225	TT225/16	-15	82	50	864	800	68	17	27	M16	140	M16	65	17	670	740	20.4
250	TT280/20	-16	116	70	1072	1000	90	20	27	M18	150	M20	80	20	870	940	43.0

Accessories

Slide rails for motor sizes 280–400

01 Slide rails for motor sizes 280–315

02 Slide rails for motor sizes 355–400

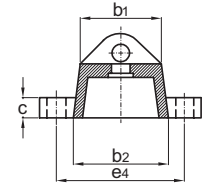
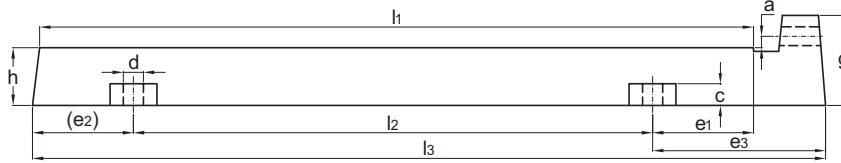

01

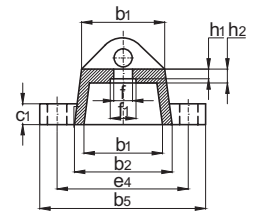
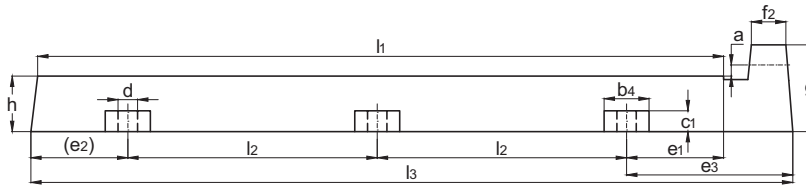

02

Note: Slide rails that do not fulfill the DIN standard are available for motor size 450 on request.

A set of slide rails includes two complete rails with screws for mounting the motor on the rails. Screws for mounting the rails on the foundation are not included. Slide rails have unmachined lower surfaces and should be supported in a suitable manner before tightening down.

Slide rails can be ordered with article numbers shown in the table.

Motor size	Article no.	l1	l2	l3	a	h	b1	b2	c	d	e1	e2	e3	e4	Bolts to feet	Horizontal bolts	Weight kg / 2 pc
280	3GZF334730-55	800	600	900	16	75	100	120	35	28	100	100	200	165	M20x90	M24x300	50
315	3GZF334730-56	1000	720	1100	16	80	120	140	40	28	140	140	240	190	M24x100	M24x300	80
355–400	3GZF334730-57	1250	485	1350	16	80	120	140	35	28	140	140	240	190	M24x100	M24x300	90

Motors in brief

Motor sizes 71-132

Motor size		71	80	90	100	112	132
Stator and end shields	Material	Cast iron					
	Paint color shade	Munsell blue 8B 4.5/3.25					
	Corrosion class	C3					
Feet		Integrated cast iron feet					
Bearings	D-end	6203-2Z/C3	6204-2Z/C3	6205-2Z/C3	6206-2Z/C3	6206-2Z/C3	6208-2Z/C3
	N-end	6202-2Z/C3	6203-2Z/C3	6204-2Z/C3	6205-2Z/C3 ^{*)}	6206-2Z/C3 ^{*)}	6208-2Z/C3
Axially locked bearings		Locked at D-end					
Bearing seals	D-end	Gamma seal					
	N-end	Gamma seal					
Lubrication		Permanently lubricated shielded bearings					
Measuring nipples for condition monitoring of the bearings		Not included					
Rating plate	Material	Stainless steel					
Terminal box	Frame and cover	Cast iron					
	Corrosion class	C3					
	Cover screws	Zinc-electroplated steel					
Connections	Threaded openings	2xM16	2xM25	2xM25	2xM32		
	Terminals	6 terminals for connection with cable lugs (not included)					
	Cable glands	Glands as option					
Fan	Material	Glass-fiber reinforced polypropylene					
Fan cover	Material	Steel					
	Paint color shade	Munsell blue 8B 4.5/3.25					
	Corrosion class	C3					
Stator winding	Material	Copper					
	Insulation	Insulation class F. Temperature rise class B unless otherwise stated.					
	Winding protection	3 PTC thermistors, 150 °C					
Rotor	Material	Pressure die-cast aluminum					
Balancing method		Half-key balancing					
Keyway		Closed keyway					
Drain holes		Drain holes with closable plastic plugs, open on delivery					
Enclosure		IP 55					
Cooling method		IC 411					

^{*)}6206-2Z/C3 in IE4

^{**)}6205-2Z/C3 in IE2

Motors in brief

Cast iron motors, sizes 160–250

Motor size		160	180	200	225	250
Stator and end shields	Material	Cast iron				
	Paint color shade	Munsell blue 8B 4.5/3.25				
	Corrosion class	C3				
Feet		Integrated cast iron feet, bolted feet when terminal box on LHS/RHS				
Bearings	D-end	6309/C3	6310/C3	6312/C3	6313/C3	6315/C3
	N-end	6209/C3	6209/C3	6210/C3	6212/C3	6213/C3
Axially locked bearings		Locked at D-end				
Bearing seals	D-end	Gamma seal				
	N-end	Gamma seal				
Lubrication		Regreasable bearings, regreasing nipples M6x1				
Measuring nipples for condition monitoring of the bearings		Included				
Rating plate	Material	Stainless steel				
Terminal box	Frame and cover	Cast iron				
	Corrosion class	C3				
	Cover screws	Zinc-electroplated steel				
Connections	Threaded openings	2xM40 + 2xM20		2xM63 + 2xM20		
	Terminals	6 terminals for connection with cable lugs (not included)				
	Cable glands	Cable flange included, glands as option				
Fan	Material	Glass-fiber reinforced polypropylene				
Fan cover	Material	Steel				
	Paint color shade	Munsell blue 8B 4.5/3.25				
	Corrosion class	C3				
Stator winding	Material	Copper				
	Insulation	Insulation class F. Temperature rise class B unless otherwise stated				
	Winding protection	3 PTC thermistors, 150 °C				
Rotor	Material	Pressure die-cast aluminum				
Balancing method		Half-key balancing as standard				
Keyway		Closed keyway				
Drain holes		Drain holes with closable plastic plugs, open on delivery				
Enclosure		IP 55				
Cooling method		IC 411				

Motors in brief

Cast iron motors, sizes 280–500

Motor size		280	315	355	400	450	500	
Stator and end shields	Material	Cast iron						
	Paint color shade	Munsell blue 8B 4.5/3.25						
	Corrosion class	C3						
Feet	Integrated cast iron feet							
Bearings	D-end	2-pole	6316/C3	6316/C3	6316M/C3	6317M/C3	6317M/C3	6330M/C3
		4–12 pole	6316/C3	6319/C3	6322/C3	6324/C3	6326M/C3	6326/C3
	N-end	2-pole	6316/C3	6316/C3	6316M/C3	6317M/C3	6317M/C3	
		4–12 pole	6316/C3	6316/C3	6316/C3	6319/C3	6322/C3	
Axially locked bearings	Locked at D-end							
Bearing seals	D-end	V-ring or labyrinth seal					Labyrinth seal	
	N-end	V-ring or labyrinth seal					Labyrinth seal	
Lubrication	Regreasable bearings, regreasing nipples M10x1							
Measuring nipples for condition monitoring of the bearings	Included							
Rating plate	Material	Stainless steel						
Terminal box	Frame and cover	Cast iron				Cast iron frame, steel cover		
	Corrosion class	C3						
	Cover screws	Zinc-electroplated steel						
Connections	Threaded openings	2xM63 +	2xM63 +	2xM63 +	2xM75 +	4xM75 +	4xM75 +	
		2xM20	2xM20	2xM20	2xM20	2xM20	2xM20	
		2xM75 +	2xM75 +	4xM75 +				
		2xM20	2xM20	2xM20				
				4xM75 +				
			2xM20					
	See section Standard terminal box for detailed information.							
	Terminals	6 terminals for connection with cable lugs (not included)						
	Cable glands	Cable flange included, glands as option						
Fan	Material	Glass-fiber reinforced polypropylene					Aluminum	
Fan cover	Material	Steel						
	Paint color shade	Munsell blue 8B 4.5/3.25						
	Corrosion class	C3						
Stator winding	Material	Copper						
	Insulation	Insulation class F. Temperature rise class B unless otherwise stated						
	Winding protection	3 PTC thermistors, 155 °C						
Rotor	Material	Pressure die-cast aluminum						
Balancing method	Half-key balancing							
Keyway	Open keyway							
Drain holes	Drain holes with closable plastic plugs, open on delivery							
Enclosure	IP 55							
Cooling method	IC 411							

Motor construction

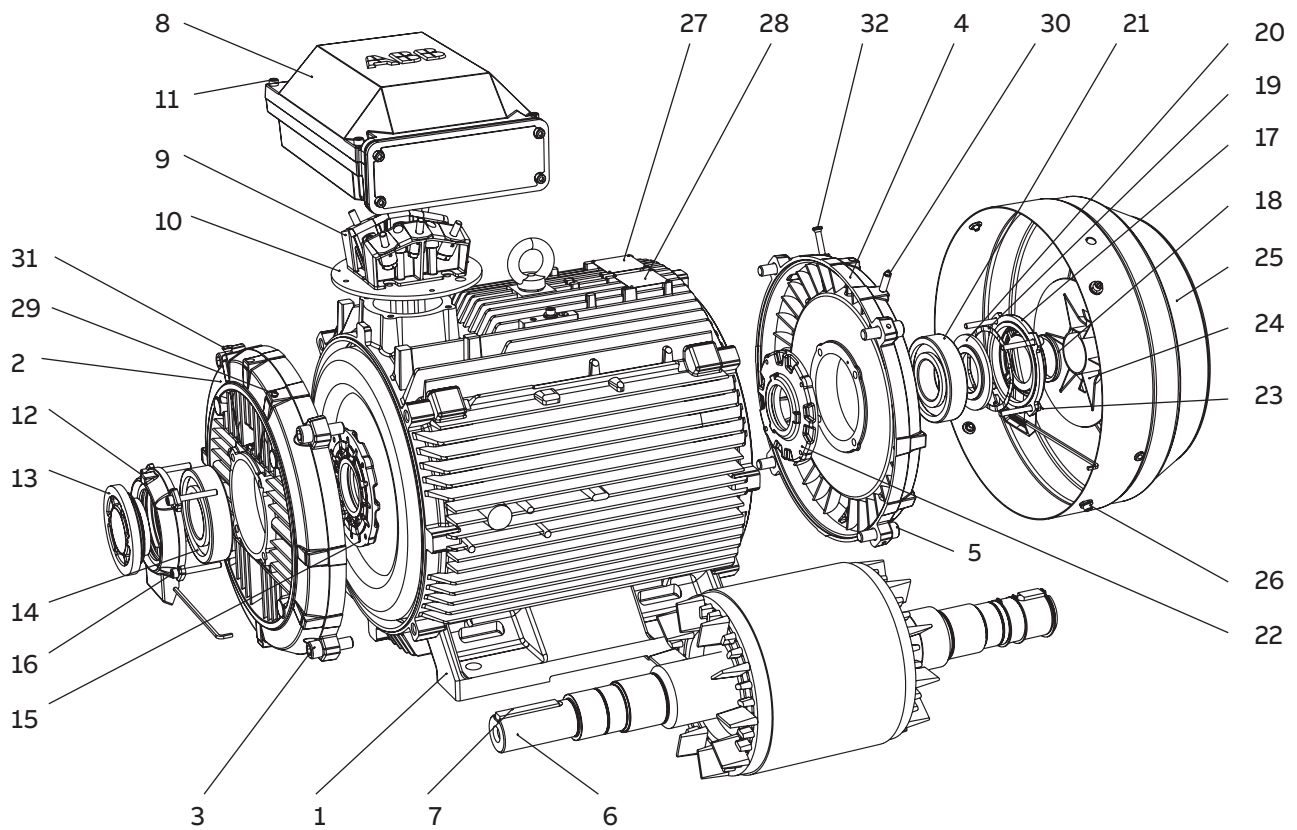

Exploded view, frame size 315

- | | | |
|----------------------------------|--|-----------------------------|
| 1 Stator frame | 13 Valve disc with labyrinth seal, D-end; standard in 2-pole motors, V-ring in 4-8 pole motors | 23 Screws for bearing cover |
| 2 End shield, D-end | 14 Bearing, D-end | 24 Fan |
| 3 Screws for end shield, D-end | 15 Inner bearing cover, D-end | 25 Fan cover |
| 4 End shield, N-end | 16 Screws for bearing cover | 26 Screws for fan cover |
| 5 Screws for end shield, N-end | 17 Outer bearing cover, N-end | 27 Rating plate |
| 6 Rotor with shaft | 18 Seal, N-end | 28 Lubrication plate |
| 7 Key, D-end | 19 Wave spring | 29 Grease nipple, D-end |
| 8 Terminal box | 20 Valve disc, N-end | 30 Grease nipple, N-end |
| 9 Terminal board | 21 Bearing, N-end | 31 SPM nipple, D-end |
| 10 Intermediate flange | 22 Inner bearing cover, N-end | 32 SPM nipple, N-end |
| 11 Screws for terminal box cover | | |
| 12 Outer bearing cover, D-end | | |

ABB Access

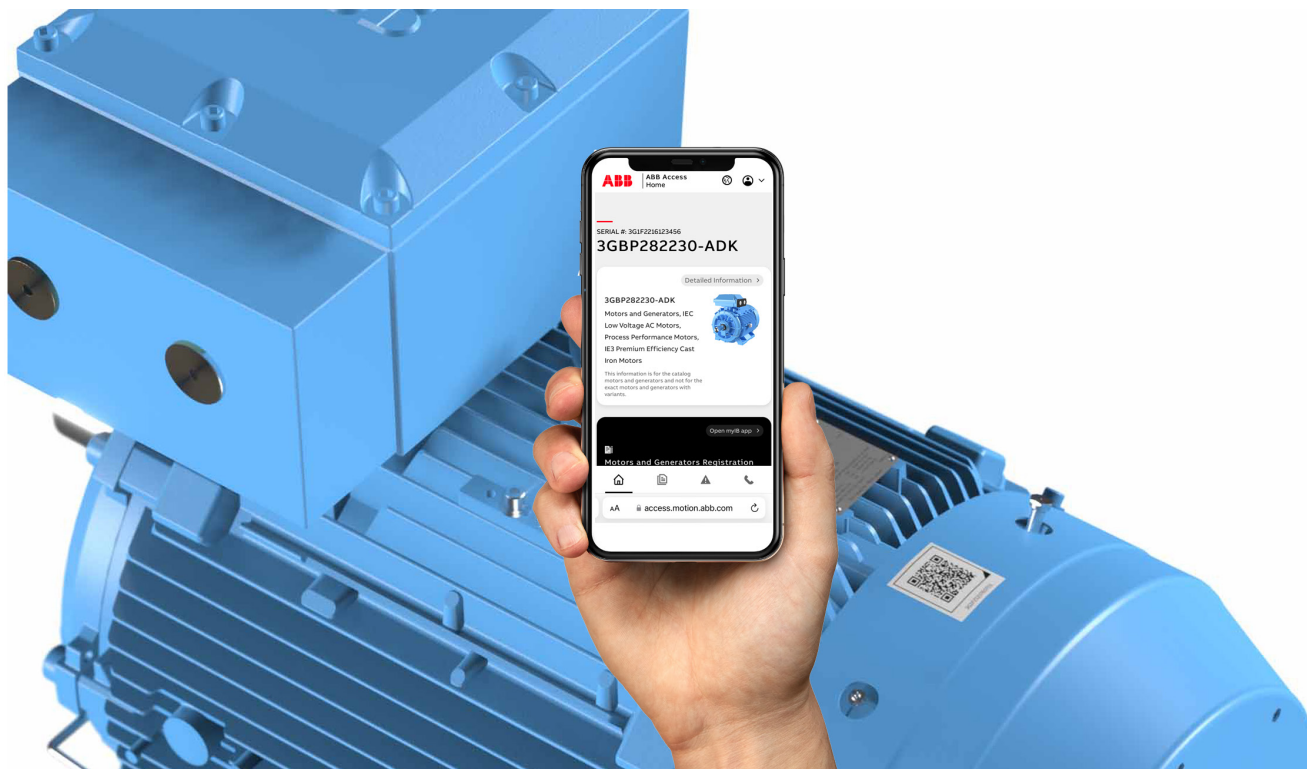

With ABB Access, you can unlock all aspects of your drives, motors or PLCs, from one central location, the palm of your hand.

Simply scan the QR code on the ABB product to get started

ABB Access helps you easily find up-to-date product online data. It also provides easy access to documentation and manuals. If you happen to experience issues with your ABB product, this can be fastly and easily reported online to reach expert support from ABB.

- Device information - Easy Access to detailed product information and EcoDesign data
- Documentation - Quick Access to user manuals and step-by-step instructions
- Report issues - Fast Access to online issue reporting
- Contact - Access ABB contacts and search Channel partners



Motors and generators with a complete portfolio of services



IEC motors

- Low voltage motors
- High voltage induction and synchronous motors
- Marine motors
- Motors for explosive atmospheres
- Motors for food and beverage
- Motors for variable speed drives
- Permanent magnet motors
- Synchronous reluctance motors

NEMA motors

- Low voltage motors
- High voltage induction and synchronous motors
- Marine motors
- Motors for explosive atmospheres
- Motors for variable speed drives
- Permanent magnet motors
- Servomotors
- Washdown motors

Generators

- Generators for wind turbines
- Generators for diesel and gas engine power plants
- Generators for steam and gas turbine power plants
- Generators for marine applications
- Generators for industrial applications
- Generators for traction applications
- Synchronous condensers for reactive power compensation

Life cycle services

ABB's portfolio of drives

Optimal solution for you



Being able to rely on the continuous high performance and efficiency of your operations is something you want to take for granted. ABB variable-frequency drives are made with all this in mind, established upon more than 40 years of experience and backed by a broad range of life cycle services.

ABB drives help you to optimize your processes and systems with state-of-the-art motor control technology, resulting in increased energy efficiency, better product quality, and reduced operating costs with higher output, less downtime, and reduced need for maintenance. All ABB drives are designed for easy selection, ordering, installation and use, and they offer integrated safety features, giving you more time to focus on what matters for you and your business.

Our portfolio offers low-voltage AC and DC drives, medium-voltage AC drives, and motion control drives spanning the fractional-kilowatt to multi-

megawatt power level. There is a drive available for essentially every industry and application and for all types of motors, in environments ranging from water utility facilities to clean electrical rooms, and to harsh coal mines and windy offshore platforms to food and beverage production. This wide product range allows you to select the best-fitting drive solution, providing maximum reliability and efficiency for every need.

—
For more information and contact details:

www.abb.com/motors&generators